

Rosemount 3051S Series

Scalable Pressure, Flow, and Level Solution

with HART® Protocol



HART
COMMUNICATION PROTOCOL

ROSEMOUNT®

www.rosemount.com



EMERSON™
Process Management

Rosemount 3051S Series Scalable Pressure, Flow, and Level Solutions

NOTICE

Read this manual before working with the product. For personal and system safety, and for optimum product performance, make sure you thoroughly understand the contents before installing, using, or maintaining this product.

For technical assistance, contacts are listed below:

Customer Central

Technical support, quoting, and order-related questions.

United States - 1-800-999-9307 (7:00 am to 7:00 pm CST)

Asia Pacific- 65 777 8211

Europe/ Middle East/ Africa - 49 (8153) 9390

North American Response Center

Equipment service needs.

1-800-654-7768 (24 hours—including Canada)

Outside of these areas, contact your local Emerson Process Management representative.

⚠ CAUTION

The products described in this document are NOT designed for nuclear-qualified applications. Using non-nuclear qualified products in applications that require nuclear-qualified hardware or products may cause inaccurate readings.

For information on Rosemount nuclear-qualified products, contact your local Emerson Process Management Sales Representative.

Table of Contents

SECTION 1	Using This Manual	1-1
Introduction	Models Covered	1-2
	Service Support	1-3
	Product Recycling/Disposal	1-3
SECTION 2	Overview	2-1
Installation	Safety Messages	2-1
	Warnings	2-1
	Considerations	2-2
	General	2-2
	Mechanical	2-2
	Draft Range	2-3
	Environmental	2-3
	Installation Procedures	2-5
	Mount the Transmitter	2-6
	Process Connections	2-11
	Consider Housing Rotation	2-12
	Configure Security and Alarm	2-13
	Connect Wiring and Power Up	2-16
	Remote Display Wiring and Power Up	2-18
	Quick Connect Wiring	2-20
	Conduit Electrical Connector Wiring (Option GE or GM)	2-21
	Grounding	2-21
	Installing the LCD Display	2-21
	Rosemount 305, 306 and 304 Manifolds	2-22
	Rosemount 305 Integral Manifold Installation Procedure	2-23
	Rosemount 306 In-Line Manifold Installation Procedure	2-23
	Rosemount 304 Conventional Manifold Installation Procedure	2-24
	Rosemount 305 and 304 Manifold Styles	2-24
	Manifold Operation	2-25

Rosemount 3051S Series

SECTION 3 Configuration

Overview	3-1
Safety Messages	3-1
Warnings	3-1
Commissioning on the Bench with HART	3-2
Setting the Loop to Manual.	3-2
Wiring Diagrams	3-3
Review Configuration Data	3-4
Field Communicator.	3-5
Field Communicator User Interface	3-5
Traditional Interface Menu Tree	3-6
Device Dashboard Menu Tree	3-7
Traditional Fast Key Sequence	3-10
Device Dashboard Fast Key Sequence	3-11
Check Output.	3-12
Process Variables.	3-12
Module Temperature	3-12
Basic Setup	3-13
Set Process Variable Units.	3-13
Set Output (Transfer function)	3-13
Rerange	3-14
Damping	3-16
LCD Display.	3-17
Detailed Setup	3-18
Failure Mode Alarm and Saturation	3-18
Alarm and Saturation Level Configuration	3-19
Alarm and Saturation Levels for Burst Mode	3-19
Alarm and Saturation Values for Multidrop Mode.	3-20
Alarm Level Verification	3-20
Process Alerts	3-20
Scaled Variable Configuration	3-21
Re-mapping	3-24
Sensor Temperature Unit	3-25
Diagnostics and Service	3-25
Loop Test	3-26
Advanced Functions for HART Protocol	3-27
Saving, Recalling, and Cloning Configuration Data	3-27
Burst Mode	3-29
Multidrop Communication	3-30
Changing a Transmitter Address	3-31
Communicating with a Multidropped Transmitter	3-31
Polling a Multidropped Transmitter.	3-31

SECTION 4	Overview	4-1
Operation and Maintenance	Calibration for HART Protocol	4-1
	Calibration Overview	4-2
	Determining Calibration Frequency	4-4
	Choosing a Trim Procedure	4-5
	Sensor Trim Overview	4-5
	Zero Trim	4-6
	Sensor Trim	4-6
	Recall Factory Trim—Sensor Trim	4-7
	Analog Output Trim	4-7
	Digital-to-Analog Trim	4-8
	Digital-to-Analog Trim Using Other Scale	4-9
	Recall Factory Trim—Analog Output	4-10
	Line Pressure Effect (Range 2 and Range 3)	4-10
	Compensating for Line Pressure (Range 4 and Range 5)	4-10
	Diagnostic Messages	4-13
	Field Upgrades	4-15
	Labeling	4-15
	Upgrading Electronics	4-15
SECTION 5	Overview	5-1
Troubleshooting	Safety Messages	5-1
	Warnings	5-1
	Disassembly Procedures	5-3
	Remove from Service	5-3
	Remove Terminal Block	5-3
	Remove Interface Assembly	5-4
	Remove the SuperModule from the Housing	5-4
	Reassembly Procedures	5-5
	Attach SuperModule to PlantWeb or Junction Box Housing	5-5
	Install Interface Assembly in the PlantWeb Housing	5-5
	Install the Terminal Block	5-5
	Reassemble the Process Flange	5-6
SECTION 6	Safety Messages	6-1
Safety Instrumented Systems	Warnings	6-1
	Certification	6-2
	3051S Safety Certified Identification	6-2
	Installation	6-2
	Commissioning	6-3
	Damping	6-3
	Alarm and Saturation Levels	6-3
	Operation and Maintenance	6-5
	Proof Test	6-5
	Inspection	6-6
	Specifications	6-6
	Failure Rate Data	6-6
	Product Life	6-6
	Spare Parts	6-6

Rosemount 3051S Series

SECTION 7 Advanced HART Diagnostic Suite

Overview	7-1
User Interface	7-3
Diagnostic Action Settings	7-3
Statistical Process Monitoring	7-4
Introduction	7-4
Overview	7-5
Assigning Statistical Values to Outputs	7-8
SPM Configuration	7-9
Operation	7-16
Troubleshooting the SPM Diagnostic	7-19
Power Advisory	7-20
Introduction	7-20
Overview	7-21
Configuration	7-21
Troubleshooting	7-24
Diagnostic Log	7-24
Overview	7-24
Variable Logging	7-26
Overview	7-26
Pressure Variable Log	7-26
Temperature Variable Log	7-28
Process Alerts	7-29
Overview	7-29
Pressure Alerts	7-29
Temperature Alerts	7-30
Service Alerts	7-31
Overview	7-31
Device Diagnostics	7-32
Overview	7-32
mA Output Diagnostic	7-33
Transmitter Power Consumption	7-33
Smart Wireless THUM Adapter Configuration	7-33
Overview	7-33
Installation and Commissioning	7-34
Rosemount 333 Hart Tri-Loop Configuration	7-34
Overview	7-34
Installation and Commissioning	7-34
Safety Instrumented Systems (SIS) Certification	7-36
3051S Safety Certified Identification	7-36
3051S SIS Installation	7-36
3051S SIS Commissioning	7-36
3051S SIS Operation and Maintenance	7-38
Inspection	7-39
3051S SIS Specifications	7-39
Other Information	7-40
Digital Trim with Non-DD Based Communicators	7-40
Temperature Rating	7-40
Field Communicator Menu Trees	7-41

APPENDIX A
Specifications and
Reference Data

Performance Specifications	A-1
Conformance to Specification ($\pm 3s$ (Sigma))	A-1
Reference Accuracy	A-1
Transmitter Total Performance	A-2
Long Term Stability	A-2
Warranty	A-3
Dynamic Performance	A-3
Ambient Temperature Effect	A-4
Mounting Position Effects	A-5
Line Pressure Effect	A-5
Vibration Effect	A-5
Power Supply Effect	A-5
Electromagnetic Compatibility (EMC)	A-5
Transient Protection (Option T1)	A-5
Functional Specifications	A-6
Range and Sensor Limits	A-6
Minimum Span Limits	A-7
Overpressure Limits	A-9
Static Pressure Limits	A-9
Burst Pressure Limits	A-9
Temperature Limits	A-10
Humidity Limits	A-11
Turn-On Time	A-11
Volumetric Displacement	A-11
Damping	A-11
Failure Mode Alarm	A-11
Physical Specifications	A-12
Safety-Certified Transmitter Failure Values	A-12
Electrical Connections	A-12
Process Connections	A-12
Process-Wetted Parts	A-12
Non-Wetted Parts	A-13
Shipping Weights	A-14
Dimensional Drawings	A-16
Ordering Information	A-23
Exploded View Diagram	A-41
Spare Parts	A-42

APPENDIX B
Product
Certifications

Approved Manufacturing Locations	B-1
Ordinary Location Certification for FM	B-1
Hazardous Locations Certifications	B-2
Installation Drawings	B-10
Factory Mutual (FM)	B-10
Canadian Standards Association (CSA)	B-27
KEMA	B-40

Rosemount 3051S Series

Reference Manual
00809-0100-4801, Rev FA
October 2010

Section 1 Introduction

Using This Manual	page 1-1
Models Covered	page 1-2
Service Support	page 1-3
Product Recycling/Disposal	page 1-3

USING THIS MANUAL

The sections in this manual provide information on installing, operating, and maintaining the Rosemount 3051S pressure transmitter with HART® protocol. The sections are organized as follows:

- **Section 2: Installation** contains mechanical and electrical installation instructions, and field upgrade options.
- **Section 3: Configuration** provides instruction on commissioning and operating 3051S transmitters. Information on software functions, configuration parameters, and online variables is also included.
- **Section 4: Operation and Maintenance** contains operation and maintenance techniques.
- **Section 5: Troubleshooting** provides troubleshooting techniques for the most common operating problems.
- **Section 6: Safety Instrumented Systems** contains identification, commissioning, maintenance, and operations information for the 3051S SIS Safety Transmitter.
- **Section 7: Advanced HART Diagnostics** contains procedures for installation, configuration, and operation of the 3051S HART Diagnostics option.
- **Appendix A: Specifications and Reference Data** supplies reference and specification data, as well as ordering information.
- **Appendix B: Product Certifications** contains intrinsic safety approval information, European ATEX directive information, and approval drawings.

For Rosemount 3051S with FOUNDATION™ fieldbus, see Manual 00809-0200-4801.

Rosemount 3051S Series

MODELS COVERED

The following 3051S pressure transmitters and the Rosemount 300S Housing Kit are covered in this manual.

Rosemount 3051S Coplanar™ Pressure Transmitter

Performance Class	Measurement Type		
	Differential	Gage	Absolute
Ultra	X	X	X
Ultra for Flow	X	–	–
Classic	X	X	X

Rosemount 3051S In-Line Pressure Transmitter

Performance Class	Measurement Type		
	Differential	Gage	Absolute
Ultra	–	X	X
Classic	–	X	X

Rosemount 3051S Liquid Level Pressure Transmitter

Performance Class	Measurement Type		
	Differential	Gage	Absolute
Classic	X	X	X

Rosemount 3051S SIS Safety Certified Transmitter

Performance Class	Measurement Type		
	Differential	Gage	Absolute
Classic	X	X	X

Rosemount 3051S HART Diagnostics Transmitter

Performance Class	Measurement Type		
	Differential	Gage	Absolute
Ultra	X	X	X
Ultra for Flow	X	–	–
Classic	X	X	X

Rosemount 300S Scalable Housing Kits

Kits are available for all models of 3051S pressure transmitters.

SERVICE SUPPORT

To expedite the return process outside of the United States, contact the nearest Emerson Process Management representative.

Within the United States, call the Emerson Process Management Instrument and Valves Response Center using the 1-800-654-RSMT (7768) toll-free number. This center, available 24 hours a day, will assist you with any needed information or materials.

The center will ask for product model and serial numbers, and will provide a Return Material Authorization (RMA) number. The center will also ask for the process material to which the product was last exposed.

CAUTION

Individuals who handle products exposed to a hazardous substance can avoid injury if they are informed of and understand the hazard. If the product being returned was exposed to a hazardous substance as defined by OSHA, a copy of the required Material Safety Data Sheet (MSDS) for each hazardous substance identified must be included with the returned goods.

Emerson Process Management Instrument and Valves Response Center representatives will explain the additional information and procedures necessary to return goods exposed to hazardous substances.

PRODUCT RECYCLING/DISPOSAL

Recycling of equipment and packaging should be taken into consideration and disposed of in accordance with local and national legislation/regulations.

Rosemount 3051S Series

Reference Manual
00809-0100-4801, Rev FA
October 2010

Section 2 Installation

Overview	page 2-1
Safety Messages	page 2-1
Considerations	page 2-2
Installation Procedures	page 2-5
Installing the LCD Display	page 2-21
Rosemount 305, 306 and 304 Manifolds	page 2-22

OVERVIEW

The information in this section covers installation considerations for HART protocol. A Quick Installation Guide for HART protocol (document number 00825-0100-4801) is shipped with every transmitter to describe basic installation, wiring, and startup procedures. Dimensional drawings for each Rosemount 3051S variation and mounting configuration are included in Appendix A: Specifications and Reference Data.

Instructions for performing configuration functions are given for Field Communicator version 3.3 and AMS version 7.0, with the exception of Section 7 Advanced HART Diagnostics. For convenience, Field Communicator fast key sequences are labeled “Fast Keys” for each software function below the appropriate headings.

SAFETY MESSAGES

Procedures and instructions in this section may require special precautions to ensure the safety of the personnel performing the operation. Information that raises potential safety issues is indicated with a warning symbol (). Refer to the following safety messages before performing an operation preceded by this symbol.

Warnings

 WARNING
<p>Explosions can result in death or serious injury.</p> <ul style="list-style-type: none">• Do not remove the transmitter covers in explosive environments when the circuit is live.• Fully engage both transmitter covers to meet explosion-proof requirements.• Before connecting a communicator in an explosive atmosphere, make sure the instruments in the loop are installed in accordance with intrinsically safe or non-incendive field wiring practices.• Verify that the operating atmosphere of the transmitter is consistent with the appropriate hazardous locations certifications.

WARNING

Electrical shock can result in death or serious injury.

- Avoid contact with the leads and terminals.

Process leaks could result in death or serious injury.

- Install and tighten all four flange bolts before applying pressure.
- Do not attempt to loosen or remove flange bolts while the transmitter is in service.

Replacement equipment or spare parts not approved by Rosemount Inc. for use as spare parts could reduce the pressure retaining capabilities of the transmitter and may render the instrument dangerous.

- Use only bolts supplied or sold by Rosemount Inc. as spare parts.

Improper assembly of manifolds to traditional flange can damage SuperModule™ Platform.

- For safe assembly of manifold to traditional flange, bolts must break back plane of flange web (i.e., bolt hole) but must not contact module housing.

SuperModule and electronics housing must have equivalent approval labeling in order to maintain hazardous location approvals.

- When upgrading, verify SuperModule and electronics housing certifications are equivalent. Differences in temperature class ratings may exist, in which case the complete assembly takes the lowest of the individual component temperature classes (for example, a T4/T5 rated electronics housing assembled to a T4 rated SuperModule is a T4 rated transmitter.)

CONSIDERATIONS

General

Measurement performance depends upon proper installation of the transmitter and impulse piping. Mount the transmitter close to the process and use minimum piping to achieve best performance. Also, consider the need for easy access, personnel safety, practical field calibration, and a suitable transmitter environment. Install the transmitter to minimize vibration, shock, and temperature fluctuation.

IMPORTANT

Install the enclosed pipe plug (found in the box) in the unused conduit opening. For straight threads, a minimum of 6 threads must be engaged. For tapered threads, install the plug wrench-tight.

For material compatibility considerations, see document number 00816-0100-3045 on www.rosemount.com.

Mechanical

Steam Service

For steam service or for applications with process temperatures greater than the limits of the transmitter, do not blow down impulse piping through the transmitter. Flush lines with the blocking valves closed and refill lines with water before resuming measurement.

Side Mounting

When the transmitter is mounted on its side, position the Coplanar flange to ensure proper venting or draining. Mount the flange as shown in Figure 2-3 on page 2-11, keeping drain/vent connections on the bottom for gas service and on the top for liquid service.

Draft Range

Installation

For the 3051S_CD0 draft range pressure transmitter, it is best to mount the transmitter with the isolators parallel to the ground. Installing the transmitter in this way reduces oil mounting effect and provides for optimal temperature performance.

Be sure the transmitter is securely mounted. Tilting of the transmitter may cause a zero shift in the transmitter output.

Reducing Process Noise

There are two recommended methods of reducing process noise: output damping and, in gage applications, reference side filtering.

Output Damping

The output damping is factory set to 3.2 seconds as a default. If the transmitter output is still noisy, increase the damping time. If faster response is needed, decrease the damping time. Damping adjustment information is available on Damping on page 3-11.

Reference Side Filtering

In gage applications it is important to minimize fluctuations in atmospheric pressure to which the low side isolator is exposed. One method of reducing fluctuations in atmospheric pressure is to attach a length of tubing to the reference side of the transmitter to act as a pressure buffer.

Another method is to plumb the reference side to a chamber that has a small vent to atmosphere. If multiple draft transmitters are being used in an application, the reference side of each device can be plumbed to a chamber to achieve a common gage reference.

Environmental

Access requirements and cover installation on page 2-5 can help optimize transmitter performance. Mount the transmitter to minimize ambient temperature changes, vibration, mechanical shock, and to avoid external contact with corrosive materials. Appendix A: Specifications and Reference Data lists temperature operating limits.

Rosemount 3051S Series

Figure 2-1. HART Installation
Flowchart

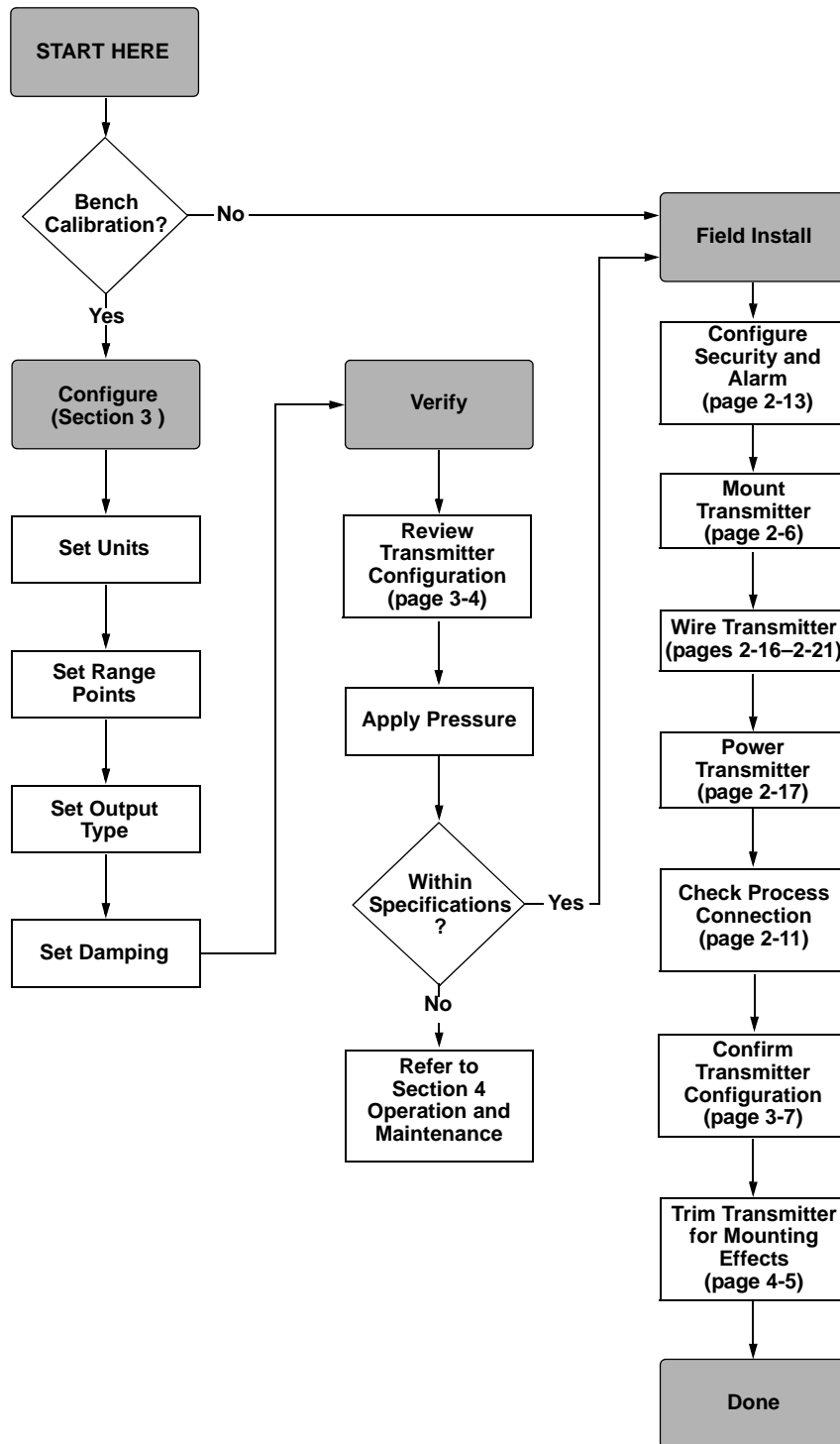

INSTALLATION PROCEDURES

For dimensional drawing information refer to Appendix A: Specifications and Reference Data on page A-16.

Process Flange Orientation

Mount the process flanges with sufficient clearance for process connections. For safety reasons, place the drain/vent valves so the process fluid is directed away from possible human contact when the vents are used. In addition, consider the need for a testing or calibration input.

Housing Rotation

See "Consider Housing Rotation" on page 2-12.

Terminal Side of Electronics Housing

Mount the transmitter so the terminal side is accessible. Clearance of 0.75 in. (19 mm) is required for cover removal. Use a conduit plug in the unused conduit opening.

Circuit Side of Electronics Housing

Provide 0.75 in. (19 mm) of clearance for units without an LCD display. Three inches of clearance is required for cover removal if a meter is installed.

Cover Installation

Always ensure a proper seal by installing the electronics housing cover(s) so that metal contacts metal. Use Rosemount O-rings.

Conduit Entry Threads

For NEMA 4X, IP66, and IP68 requirements, use thread seal (PTFE) tape or paste on male threads to provide a watertight seal.

Cover Jam Screw

For transmitter housings shipped with a cover jam screw, as shown in Figure 2-2, the screw should be properly installed once the transmitter has been wired and powered up. The cover jam screw is intended to disallow the removal of the transmitter cover in flameproof environments without the use of tooling. Follow these steps to install the cover jam screw:

1. Verify that the cover jam screw is completely threaded into the housing.
2. Install the transmitter housing cover and verify that the cover is tight against the housing.
3. Using an M4 hex wrench, loosen the jam screw until it contacts the transmitter cover.
4. Turn the jam screw an additional $\frac{1}{2}$ turn counterclockwise to secure the cover. (Note: Application of excessive torque may strip the threads.)
5. Verify that the cover cannot be removed.

Figure 2-2. Cover Jam Screw

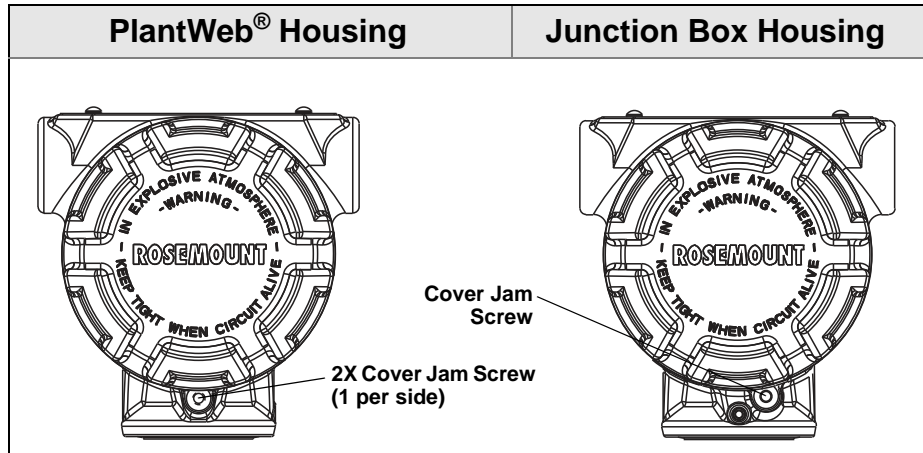

Mount the Transmitter

Mounting Brackets

Facilitate mounting transmitter to a 2-in. pipe, or to a panel. The B4 Bracket (SST) option is standard for use with the Coplanar and In-Line process connections. “Coplanar Flange Mounting Configurations” on page A-18 shows bracket dimensions and mounting configurations for the B4 option.

Options B1–B3 and B7–B9 are sturdy, epoxy/polyester-painted brackets designed for use with the traditional flange. The B1–B3 brackets have carbon steel bolts, while the B7–B9 brackets have stainless steel bolts. The BA and BC brackets and bolts are stainless steel. The B1/B7/BA and B3/B9/BC style brackets support 2-inch pipe-mount installations, and the B2/B8 style brackets support panel mounting.

NOTE

Verify transmitter zero point after installation. To reset zero point, refer to “Sensor Trim Overview” on page 4-5.

Flange Bolts

The 3051S can be shipped with a Coplanar flange or a Traditional flange installed with four 1.75-inch flange bolts. Mounting bolts and bolting configurations for the Coplanar and Traditional flanges can be found on page 2-8. Stainless steel bolts supplied by Emerson Process Management are coated with a lubricant to ease installation. Carbon steel bolts do not require lubrication. No additional lubricant should be applied when installing either type of bolt. Bolts supplied by Emerson Process Management are identified by their head markings:

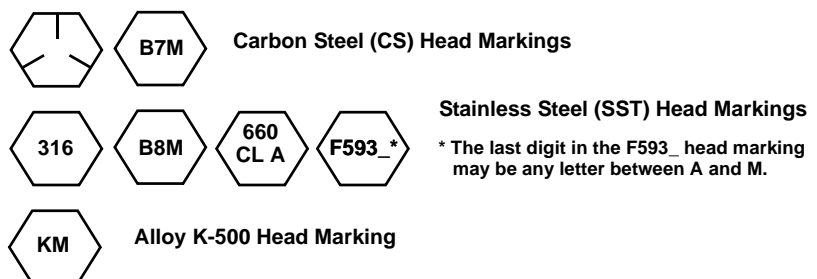

Bolt Installation



Only use bolts supplied with the Rosemount 3051S or sold by Emerson Process Management as spare parts. When installing the transmitter to one of the optional mounting brackets, torque the bolts to 125 in.-lb. (0,9 N-m). Use the following bolt installation procedure:

1. Finger-tighten the bolts.
2. Torque the bolts to the initial torque value using a crossing pattern.
3. Torque the bolts to the final torque value using the same crossing pattern.

Torque values for the flange and manifold adapter bolts are as follows:

Table 2-1. Bolt Installation Torque Values

Bolt Material	Initial Torque Value	Final Torque Value
CS-ASTM-A449 Standard	300 in.-lb (34 N-m)	650 in.-lb (73 N-m)
316 SST—Option L4	150 in.-lb (17 N-m)	300 in.-lb (34 N-m)
ASTM-A-193-B7M—Option L5	300 in.-lb (34 N-m)	650 in.-lb (73 N-m)
Alloy K-500 —Option L6	300 in.-lb (34 N-m)	650 in.-lb (73 N-m)
ASTM-A-453-660—Option L7	150 in.-lb (17 N-m)	300 in.-lb (34 N-m)
ASTM-A-193-B8M—Option L8	150 in.-lb (17 N-m)	300 in.-lb (34 N-m)

Rosemount 3051S Series

DIFFERENTIAL TRANSMITTER

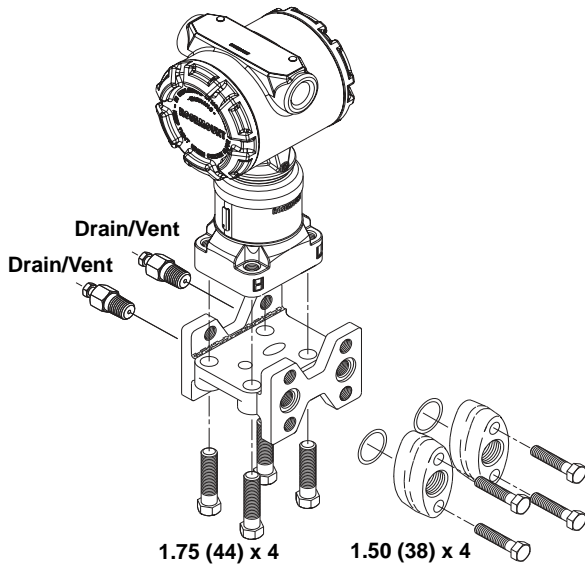

GAGE/ABSOLUTE TRANSMITTER

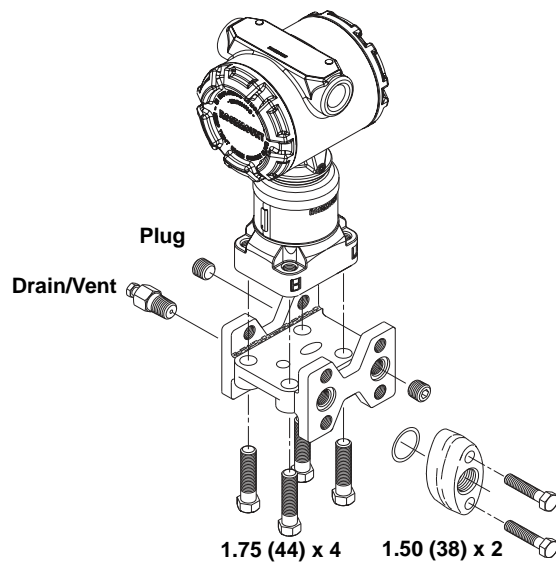

NOTE

Dimensions are in inches (millimeters).

**Transmitter with
Flange Bolts**

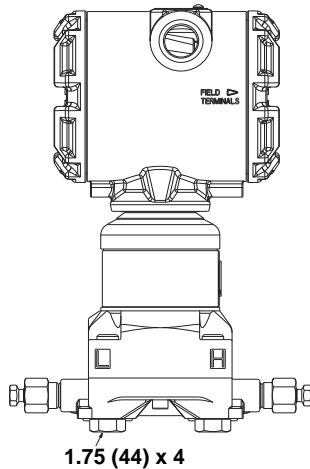

**Transmitter with
Flange Adapters
and Flange/ Adapter Bolts**

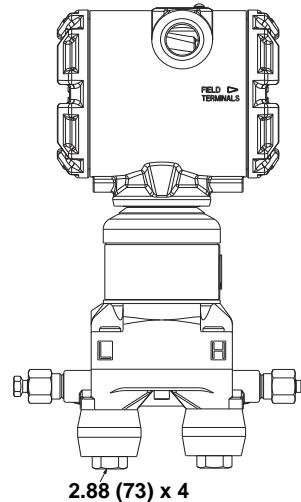

Description	Qty	Size in in. (mm)
Differential Pressure		
Flange Bolts	4	1.75 (44)
Adapter Bolts	4	1.50 (38) ⁽¹⁾
Flange/ Adapter Bolts	4	2.88 (73)
Gage/Absolute Pressure⁽²⁾		
Flange Bolts	4	1.75 (44)
Adapter Bolts	2	1.50 (38) ⁽¹⁾
Flange/ Adapter Bolts	2	2.88(73)

(1) DIN-compliant traditional flange requires 1.75 in. (44 mm) length adapter bolts.

(2) Rosemount 3051S In-line transmitters are direct mount and do not require bolts for process connection.

Impulse Piping

The piping between the process and the transmitter must accurately transfer the pressure to obtain accurate measurements. There are five possible sources of error: pressure transfer, leaks, friction loss (particularly if purging is used), trapped gas in a liquid line, liquid in a gas line, density variations between the legs, and plugged impulse piping.

The best location for the transmitter in relation to the process pipe depends on the process itself. Use the following guidelines to determine transmitter location and placement of impulse piping:

- Keep impulse piping as short as possible.
- For liquid service, slope the impulse piping at least 1 inch per foot (8 cm per m) upward from the transmitter toward the process connection.
- For gas service, slope the impulse piping at least 1 inch per foot (8 cm per m) downward from the transmitter toward the process connection.
- Avoid high points in liquid lines and low points in gas lines.
- Make sure both impulse legs are the same temperature.
- Use impulse piping large enough to avoid friction effects and blockage.
- Vent all gas from liquid piping legs.
- When using a sealing fluid, fill both piping legs to the same level.
- When purging, make the purge connection close to the process taps and purge through equal lengths of the same size pipe. Avoid purging through the transmitter.
- Keep corrosive or hot (above 250 °F [121 °C]) process material out of direct contact with the SuperModule and flanges.
- Prevent sediment deposits in the impulse piping.
- Keep the liquid head balanced on both legs of the impulse piping.
- Avoid conditions that might allow process fluid to freeze within the process flange.

Optional Advanced HART Diagnostics Electronics

Statistical Process Monitoring (SPM) provides statistical data (standard deviation, mean, coefficient of variation) that can be used to detect process and process equipment anomalies, including plugged impulse lines, air entrainment, pump cavitation, furnace flame instability, distillation column flooding and more. This diagnostic allows you to take preventative measures before abnormal process situations result in unscheduled downtime or rework.

Power Advisory diagnostic proactively detects and notifies you of degraded electrical loop integrity before it can affect your process operation. Example loop problems that can be detected include water in the terminal compartment, corrosion of terminals, improper grounding, and unstable power supplies.

The enhanced EDDL Device Dashboard presents the diagnostics in a graphical, task-based interface that provides single click access to critical process/device information and descriptive graphical troubleshooting.

Suite includes: Statistical Process Monitoring (SPM), Power Advisory, Status Log, Variable Log, Advanced Process Alerts, Service Alerts, and Time Stamp capability.

The Advanced HART Diagnostics Electronics can be ordered using option code DA2 in the transmitter model number or as a spare part (p/n 03151-9071-0001) to retrofit existing 3051S transmitters in the field. See Section 7 Advanced HART Diagnostics of this manual for more information.

NOTE

Option code DA2 or spare part (p/n 03151-9071-000X) are limited to a T4 temperature rating.

Mounting Requirements

Impulse piping configurations depend on specific measurement conditions. Refer to Figure 2-3 for examples of the following mounting configurations:

Liquid Flow Measurement

- Place taps to the side of the line to prevent sediment deposits on the process isolators.
- Mount the transmitter beside or below the taps so gases vent into the process line.
- Mount drain/vent valve upward to allow gases to vent.

Gas Flow Measurement

- Place taps in the top or side of the line.
- Mount the transmitter beside or above the taps so to drain liquid into the process line.

Steam Flow Measurement

- Place taps to the side of the line.
- Mount the transmitter below the taps to ensure that impulse piping will remain filled with condensate.
- In steam service above 250 °F (121 °C), fill impulse lines with water to prevent steam from contacting the transmitter directly and to ensure accurate measurement start-up.

NOTE

For steam or other elevated temperature services, it is important that temperatures at the process connection do not exceed the transmitter's process temperature limits. See "Process Temperature Limits" on page A-11 for details.

Figure 2-3. Coplanar Installation Examples

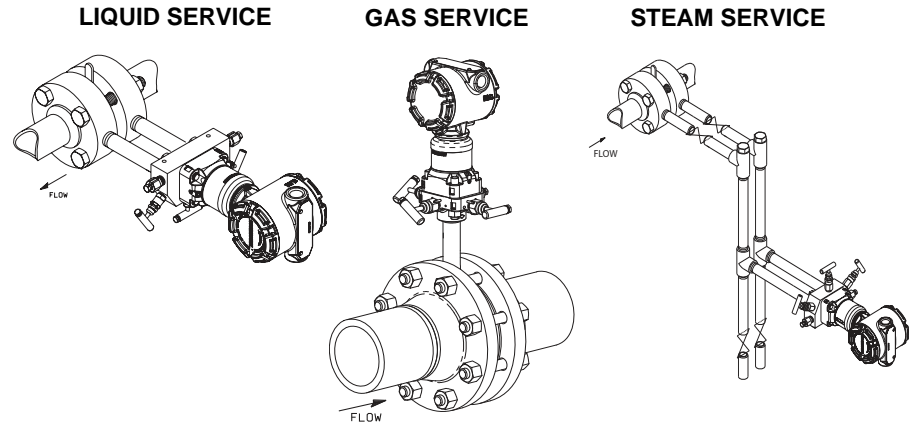
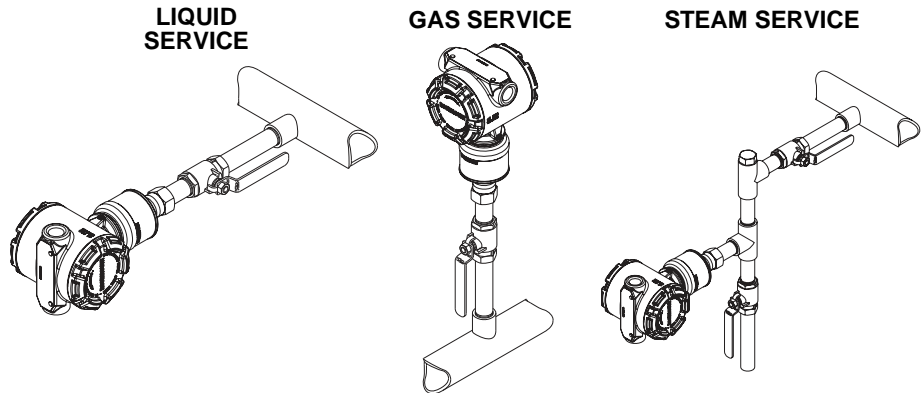

Figure 2-4. In-Line Installation Examples



Process Connections

3051S transmitter flange process connection size is $\frac{1}{4}$ –18 NPT. Flange adapters with $\frac{1}{2}$ –14 NPT connections are available as the D2 option. Use your plant-approved lubricant or sealant when making the process connections. The process connections on the transmitter flange are on $2\frac{1}{8}$ -inch (54 mm) centers to allow direct mounting to a three-valve or five-valve manifold. Rotate one or both of the flange adapters to attain connection centers of 2-in. (51 mm), $2\frac{1}{8}$ -in. (54 mm), or $2\frac{1}{4}$ -in. (57 mm).

⚠ Install and tighten all four flange bolts before applying pressure to avoid leakage. When properly installed, the flange bolts will protrude through the top of the SuperModule housing. Do not attempt to loosen or remove the flange bolts while the transmitter is in service.

To install adapters to a Coplanar flange, perform the following procedure:

1. Remove the flange bolts.
2. Leaving the flange in place, move the adapters into position with the O-ring installed.
3. Clamp the adapters and the Coplanar flange to the transmitter module using the longer of the bolts supplied.
4. Tighten the bolts. Refer to Table 2-1 on page 2-7 for torque specifications.

Figure 2-5. O-Rings.

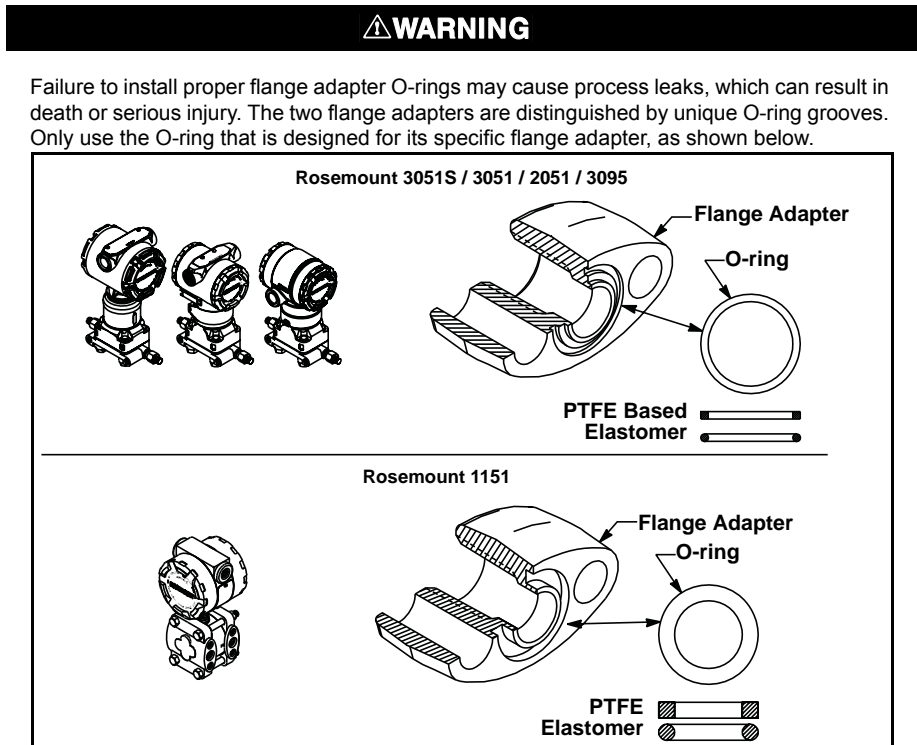

⚠ Whenever you remove flanges or adapters, visually inspect the PTFE O-rings. Replace them if there are any signs of damage, such as nicks or cuts. If you replace the O-rings, re-torque the flange bolts after installation to compensate for cold flow. Refer to the process sensor body reassembly procedure in Section 5 Troubleshooting on page 5-6.

Consider Housing Rotation

The housing can be rotated to improve field access to wiring or to better view the optional LCD display. Perform the following procedure:

Figure 2-6. Housings

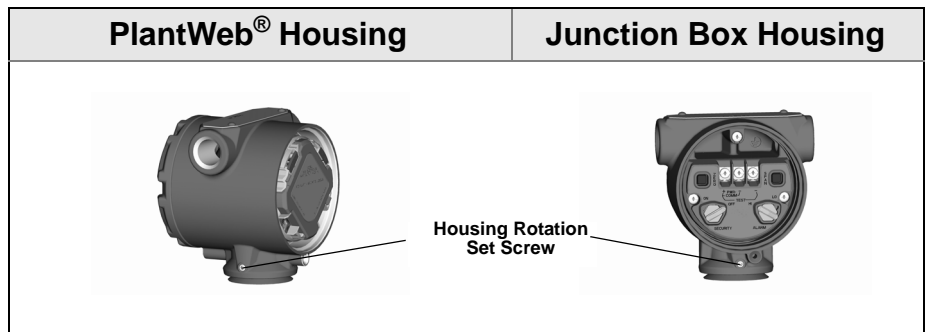

1. Loosen the housing rotation set screw.
2. Turn the housing up to 180° to the left or right of its original (as shipped) position.

NOTE

Do not rotate the housing more than 180 degrees without first performing a disassembly procedure (see “Remove Interface Assembly” on page 5-4). Over-rotation may sever the electrical connection between the sensor module and the feature board.

3. Retighten the housing rotation set screw.

In addition to housing rotation, the optional LCD display can be rotated in 90-degree increments by squeezing the two tabs, pulling out, rotating and snapping back into place.

NOTE

If LCD pins are inadvertently removed from the interface board, carefully re-insert the pins before snapping the LCD display back into place.

Configure Security and Alarm

NOTE



If alarm and security adjustments are not installed, the transmitter will operate normally with the default alarm condition alarm *high* and the security *off*.

Configure Security (Write Protect)

Changes can be prevented to the transmitter configuration data with the write protection PlantWeb housing switches and Junction Box housing jumpers. Security is controlled by the security (write protect) switch/jumper located on the interface assembly or terminal block. Position the switch/jumper in the “ON” position to prevent accidental or deliberate change of configuration data.

If the transmitter write protection switch/jumper is in the “ON” position, the transmitter will not accept any “writes” to its memory. Configuration changes, such as digital trim and reranging, cannot take place when the transmitter security is on.

To reposition the switches/jumpers, follow the procedure described below.

1. Do not remove the transmitter covers in explosive atmospheres when the circuit is live. If the transmitter is live, set the loop to manual and remove power.
-  2. Remove the electronics compartment cover, opposite the field terminal side on the PlantWeb housing or the terminal block cover on the Junction Box housing. Do not remove the transmitter covers in explosive atmospheres when the circuit is live.
3. Follow the procedure in Figure 2-7 on page 2-14 to reposition the switches/jumpers as desired for the specific housing compartment.
-  4. Re-install the transmitter cover. Transmitter covers must be fully engaged to meet explosion-proof requirements.

Rosemount 3051S Series

Figure 2-7. Switch and jumper configuration (option D1)

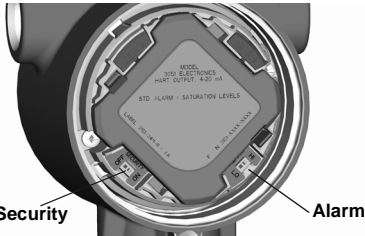
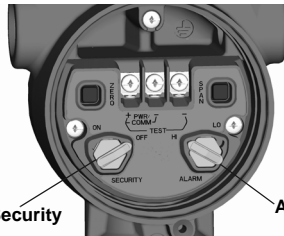
PlantWeb Housing Switches	Junction Box Housing Jumpers
 <p>Slide the security and alarm switches into the preferred position by using a small screwdriver.</p> <p>(An LCD display or an adjustment module must be in place to activate the switches.)</p>	 <p>Pull the pins out and rotate 90° into desired position to set the security and alarm.</p>

Field Communicator

Fast Keys	1, 3, 4, 5
Device Dashboard Fast Keys	2, 2, 7

Usage Note

The Field Communicator can be used to configure the security on and off. Otherwise, if the transmitter contains the D1 option, the switch/jumper will override software write protect. To disable the zero and span buttons (local keys), for transmitters with the D1 option, follow the “Local Keys Control” on page 2-14.

AMS

Right click on the device and select “Device Configuration”, then “Config Write Protect” from the menu.

1. Enter write protect setting, click **Next**.
2. Click **Next** to acknowledge setting has changed. If hardware adjustments are activated, click **Next** to acknowledge the “Switch option detected, function disabled, write protect unchanged” screen. If the hardware adjustments are activated, the write protect will not configure.
3. Click **Finish** to acknowledge the method is complete.

Local Keys Control

Local Keys control can be configured to enable or disable the use of the local zero and span buttons.

Field Communicator

Fast Keys	1, 4, 4, 1
Device Dashboard Fast Keys	2, 2, 7

1. Enter the fast key sequence “Local Keys Control” to bring up the “Field device info” screen.
2. Scroll down to Local Keys on the menu and use the right arrow key to configure Enable or Disable.

AMS

Right click on the device and select “Configure” from the menu.

1. In the “Device” tab, use the “Local keys” drop down menu to select Enable or Disable and click **Apply**.
2. After carefully reading the warning provided, select **yes**.

Configure Alarm Direction

The transmitter alarm direction is set by repositioning the PlantWeb housing switch or Junction Box housing jumper. Position the switch/ jumper in the HI position for fail high and in the LO position for fail low. See “Failure Mode Alarm and Saturation” on page 3-12 for more information.

Field Communicator

Fast Keys	1, 4, 2, 7, 6
Device Dashboard Fast Keys	2, 2, 1, 7, 1

Usage Note

The Field Communicator can be used to configure the alarm direction to High (HI) or Low (LO). Otherwise, if the transmitter contains the D1 option, the switch/jumper on the transmitter will override the Field Communicator.

AMS

Right click on the device and select “Device Configuration,” then “Alarm/Saturation Levels,” then “Alarm Direction” from the menu.

1. Enter desired alarm direction, click **Next**.
2. Click **Next** to acknowledge setting has changed. If hardware adjustments are activated, click **Next** to acknowledge the “Switch option detected, function disabled, alarm direction unchanged” screen. If the hardware adjustments are activated, the write protect will not configure.
3. Click **Finish** to acknowledge the method is complete.

Rosemount 3051S Series

Connect Wiring and Power Up

Use twisted pairs to yield best results. To ensure proper communication, use 24 AWG to 14 AWG wire, and do not exceed 5000 feet (1 500 meters).

Figure 2-8. HART Terminal Blocks

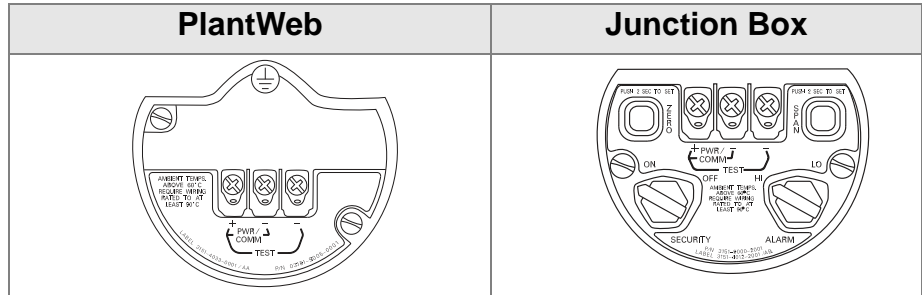

To make connections, perform the following procedure:

- ⚠ 1. Remove the housing cover on terminal compartment side. Do not remove the cover in explosive atmospheres when the circuit is live. Signal wiring supplies all power to the transmitter.
- ⚠ 2. Connect the positive lead to the terminal marked (+) and the negative lead to the terminal marked (pwr/comm –). Avoid contact with leads and terminals. Do not connect powered signal wiring to the test terminals. Power could damage the test diode.
3. Plug and seal the unused conduit connection on the transmitter housing to avoid moisture accumulation in the terminal side. Install wiring with a drip loop. Arrange the drip loop so the bottom is lower than the conduit connections and the transmitter housing.

Surges/Transients

The transmitter will withstand electrical transients of the energy level usually encountered in static discharges or induced switching transients. However, high-energy transients, such as those induced in wiring from nearby lightning strikes, can damage the transmitter.

Optional Transient Protection Terminal Block

The transient protection terminal block can be ordered as an installed option (Option Code T1 in the transmitter model number) or as a spare part to retrofit existing 3051S transmitters in the field. For a complete listing of spare part numbers for transient protection terminal blocks, refer to page A-38. A lightning bolt symbol on a terminal block identifies it as having transient protection.

Signal Wiring Grounding

Do not run signal wiring in conduit or open trays with power wiring, or near heavy electrical equipment. Grounding terminations are provided on the sensor module and inside the Terminal Compartment. These grounds are used when transient protect terminal blocks are installed or to fulfill local regulations. See Step 2 below for more information on how the cable shield should be grounded.

1. Remove the Field Terminals housing cover.
2. Connect the wiring pair and ground as indicated in Figure 2-9.
 - a. The terminals are not polarity sensitive.
 - b. The cable shield should:
 - Be trimmed close and insulated from touching the transmitter housing.
 - Continuously connect to the termination point.
 - Be connected to a good earth ground at the power supply end.

Figure 2-9. Wiring

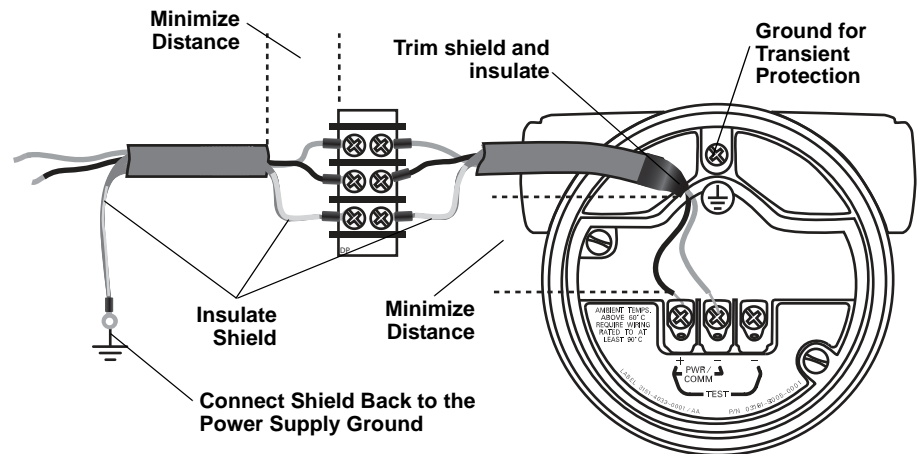

3. Replace the housing cover. It is recommended that the cover be tightened until there is no gap between the cover and the housing.
4. Plug and seal unused conduit connections.

Power Supply 4–20 mA Transmitters

The dc power supply should provide power with less than two percent ripple. Total resistance load is the sum of resistance from signal leads and the load resistance of the controller, indicator, and related pieces. Note that the resistance of intrinsic safety barriers, if used, must be included.

See “Load Limitations” on page A-7.

NOTE

A minimum loop resistance of 250 ohms is required to communicate with a Field Communicator. If a single power supply is used to power more than one 3051S transmitter, the power supply used, and circuitry common to the transmitters, should not have more than 20 ohms of impedance at 1200 Hz.

Rosemount 3051S Series

Electrical Considerations

Proper electrical installation is necessary to prevent errors due to improper grounding and electrical noise. For Junction Box housing, shielded signal wiring should be used in high EMI/RFI environments.

Remote Display Wiring and Power Up

The Remote Mount Display and Interface system consists of a local transmitter and a remote mount LCD display assembly. The local 3051S transmitter assembly includes a Junction Box housing with a three position terminal block integrally mounted to a SuperModule. The remote mount LCD display assembly consists of a dual compartment PlantWeb housing with a seven position terminal block. See Figure 2-10 on page 2-19 for complete wiring instructions. The following is a list of necessary information specific to the Remote Mount Display system:

- Each terminal block is unique for the remote display system.
- A 316 SST housing adapter is permanently secured to the remote mount LCD display PlantWeb housing providing an external ground and a means for field mounting with the provided mounting bracket.
- A cable is required for wiring between the transmitter and remote mount LCD display. The cable length is limited to 100-ft.
- 50-ft. (option M8) or 100-ft. (option M9) cable is provided for wiring between the transmitter and remote mount LCD display. Option M7 does not include cable; see recommended specifications below:

Cable type: Recommend Madison AWM Style 2549 cable. Other comparable cable may be used as long as it has independent dual twisted shielded pair wires with an outer shield. The Power wires must be 22 AWG minimum and the CAN communication wires must be 24 AWG minimum.

Cable length: Up to 100-ft. (31 m) depending upon cable capacitance.

Cable capacitance: The capacitance as wired must be less than 5000 picofarads total. This allows up to 50 picofarads per ft. (0.3 m) for a 100-ft. (31 m) cable.

Intrinsic Safety Consideration: The transmitter assembly with remote display has been approved with Madison AWM Style 2549 cable. Alternate cable may be used as long as the transmitter with remote display and cable is configured according to the installation control drawing or certificate. Refer to appropriate approval certificate or control drawing in Appendix B for remote cable IS requirements.

IMPORTANT

Do not apply power to the remote communications terminal. Follow wiring instructions carefully to prevent damage to system components.

IMPORTANT

For ambient temperatures above 140 °F (60 °C), cable wiring must be rated at least 9 °F (5 °C) above the maximum ambient temperature.

Figure 2-10. Remote Mount Display wiring diagram

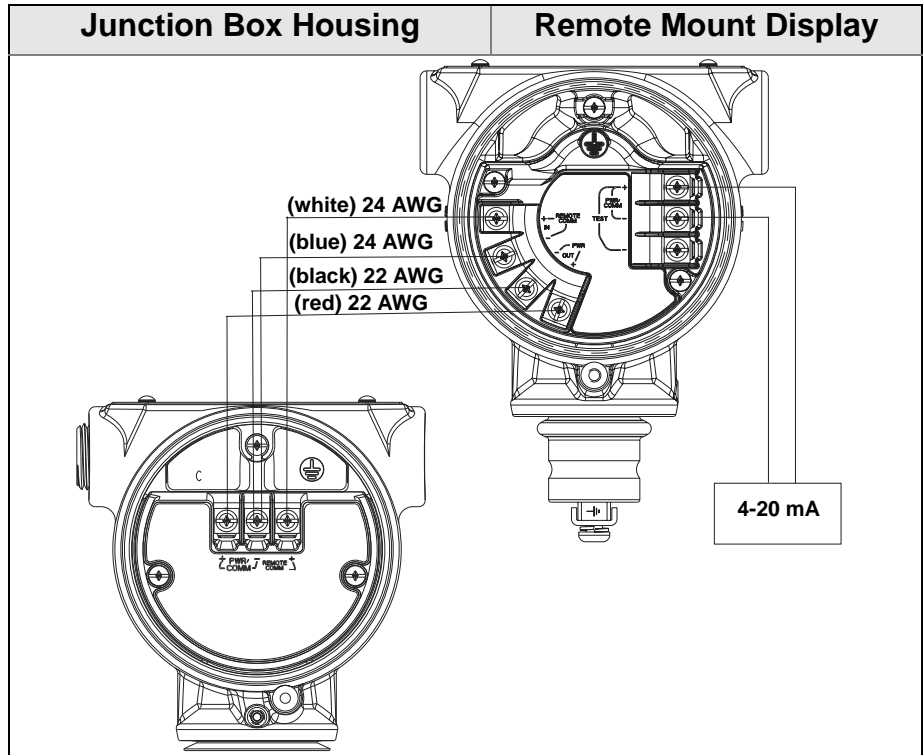

NOTE

Wire colors provided above are per Madison AWM Style 2549 cable. Wire color may vary depending on cable selected.

Madison AWM Style 2549 cable includes a ground shield. This shield must be connected to earth ground at either the SuperModule or the Remote Display, but not both.

Rosemount 3051S Series

Quick Connect Wiring

As standard, the 3051S Quick Connect arrives properly assembled to the SuperModule and is ready for installation. Cordsets and Field Wireable Connectors (in shaded area) are sold separately.

Figure 2-11. Rosemount 3051S Quick Connect Exploded View

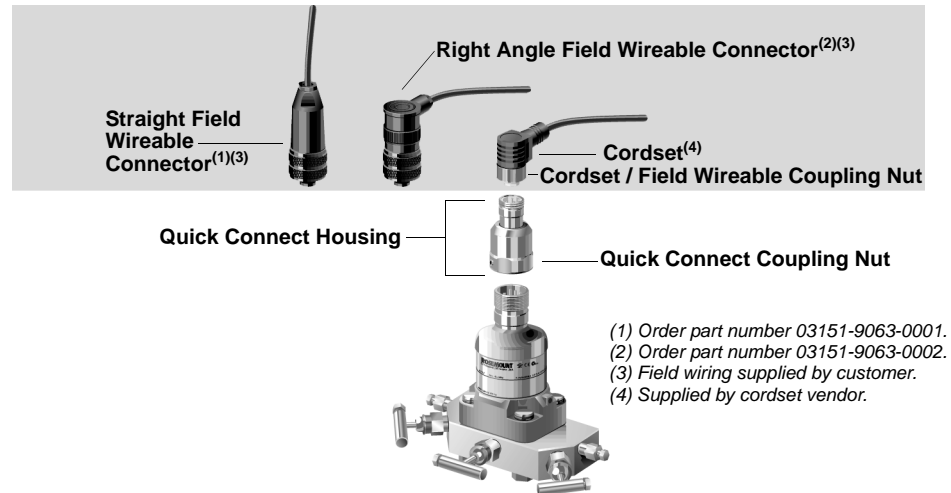

IMPORTANT

If Quick Connect is ordered as a 300S spare housing or is removed from the SuperModule, follow the instructions below for proper assembly prior to field wiring.

1. Place the Quick Connect onto the SuperModule. To ensure proper pin alignment, remove coupling nut prior to installing quick connect onto SuperModule.
2. Place coupling nut over quick connect and wrench tighten to a maximum of 300 in-lb. (34 N-m).
3. Tighten the set screw using a $\frac{3}{32}$ -in hex wrench.
4. Install Cordset/ Field Wireable Connectors onto the Quick Connect. Do not over tighten.

Figure 2-12. Quick Connect Housing Pin-Out

For other wiring details, refer to pin-out drawing and the cordset manufacturer's installation instructions.

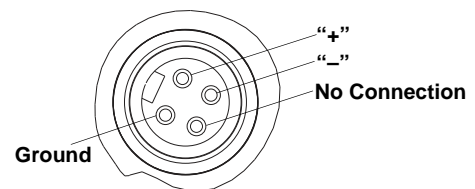

Conduit Electrical Connector Wiring (Option GE or GM)

For 3051S transmitters with conduit electrical connectors GE or GM, refer to the cordset manufacturer's installation instructions for wiring details. For FM Intrinsically Safe, non-incendive or FM FISCO Intrinsically Safe hazardous locations, install in accordance with Rosemount drawing 03151-1009 to maintain outdoor rating (NEMA 4X and IP66.) See Appendix B, page B-20.

Reassembly of Conduit Receptacles

If the conduit receptacle is removed or replaced, follow the instructions below to re-wire the GE or GM conduit receptacle to the terminal block:

1. Connect the green/yellow lead wire to the internal ground screw.
2. Connect the brown lead wire to the terminal marked (+).
3. Connect the blue lead wire to the terminal marked (pwr/comm -).

Grounding

Transmitter Case

Always ground the transmitter case in accordance with national and local electrical codes. The most effective transmitter case grounding method is a direct connection to earth ground with minimal impedance. Methods for grounding the transmitter case include:

- **Internal Ground Connection:** The Internal Ground Connection screw is inside the terminal side of the electronics housing. The screw is identified by a ground symbol () and is standard on all 3051S transmitters.
- **External Ground Assembly:** This assembly is included with the optional transient protection terminal block (Option Code T1), and it is included with ATEX Flameproof Certification (Option Code E1), ATEX Intrinsically Safe Certification (Option Code I1), and ATEX Type n Certification (Option Code N1). The External Ground Assembly can also be ordered with the transmitter (Option Code D4), or as a spare part (03151-9060-0001).

NOTE

Grounding the transmitter case using the threaded conduit connection may not provide a sufficient ground. The transient protection terminal block (Option Code T1) will not provide transient protection unless the transmitter case is properly grounded. Use the above guidelines to ground the transmitter case. Do not run transient protection ground wire with signal wiring; the ground wire may carry excessive current if a lightning strike occurs.

INSTALLING THE LCD DISPLAY

Transmitters ordered with the LCD display will be shipped with the display installed. The LCD display requires a PlantWeb housing. Installing the display on an existing 3051S transmitter requires a small instrument screwdriver and the display kit.

In addition to housing rotation, the optional LCD display can be rotated in 90-degree increments by squeezing the two tabs, pulling out, rotating and snapping back into place.

If LCD pins are inadvertently removed from the interface board, carefully re-insert the pins before snapping the LCD display back into place.

Rosemount 3051S Series

Use the following procedure and Figure 2-13 to install the LCD display:

1. **IF** the transmitter is installed in a loop, **THEN** secure the loop and disconnect power.
- ⚠ 2. Remove the transmitter cover opposite the field terminal side. Do not remove the instrument covers in explosive environments when the circuit is live.
3. Remove Hardware Adjustment Module if installed. Engage the four-pin connector into the LCD display and snap into place.
4. Install the meter cover and tighten to insure metal to metal contact.

Figure 2-13. Optional LCD Display

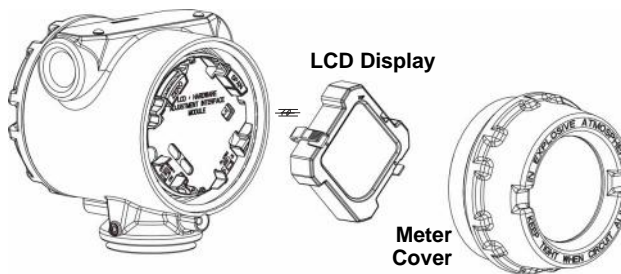

ROSEMOUNT 305, 306 AND 304 MANIFOLDS

The Rosemount 305 is available in two designs: Traditional and Coplanar. The traditional 305 Integral Manifold can be mounted to most primary elements with mounting adapters in the market today. The Rosemount 306 In-Line Manifold is used with In-line transmitters to provide block-and-bleed valve capabilities of up to 10000 psi (690 bar). The Rosemount 304 comes in two basic styles: traditional (flange x flange and flange x pipe) and wafer. The 304 traditional manifold comes in 2, 3, and 5-valve configurations. The 304 wafer manifold comes in 3 and 5 valve configurations.

Figure 2-14. Integral Manifold Designs

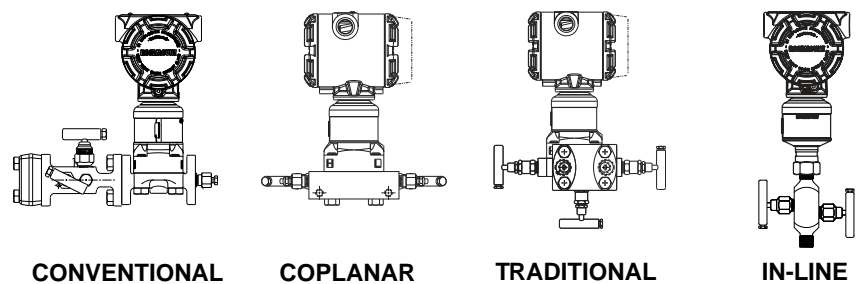

Rosemount 305 Integral Manifold Installation Procedure

To install a 305 Integral Manifold to a 3051S transmitter:

-  1. Inspect the PTFE SuperModule O-rings. If the O-rings are undamaged, reusing them is recommended. If the O-rings are damaged (if they have nicks or cuts, for example), replace them with new O-rings.

IMPORTANT

If replacing the O-rings, be careful not to scratch or deface the O-ring grooves or the surface of the isolating diaphragm when removing the damaged O-rings.

2. Install the Integral Manifold on the SuperModule. Use the four manifold bolts for alignment. Finger tighten the bolts, then tighten the bolts incrementally in a cross pattern to final torque value. See “Flange Bolts” on page 2-6 for complete bolt installation information and torque values. When fully tightened, the bolts should extend through the top of the module housing.
3. If the PTFE SuperModule O-rings have been replaced, the flange bolts should be re-tightened after installation to compensate for cold flow of the O-rings.
4. If applicable, install flange adapters on the process end of the manifold using the 1.75-in. flange bolts supplied with the transmitter.

NOTE

Always perform a zero trim on the transmitter/manifold assembly after installation to eliminate mounting effects. See “Zero Trim” on page 4-6.

Rosemount 306 In-Line Manifold Installation Procedure

The 306 Manifold is for use only with a 3051S In-line transmitter.

-  Assemble the 306 Manifold to the 3051S In-line transmitter with a thread sealant.

1. Place transmitter into holding fixture.
2. Apply appropriate thread paste or tape to threaded instrument end of the manifold.
3. Count total threads on the manifold before starting assembly.
4. Start turning the manifold by hand into the process connection on the transmitter.

NOTE

If using thread tape, be sure the thread tape does not strip when the manifold assembly is started.

5. Wrench tighten manifold into process connection.
Note: Minimum torque value is 425 in-lbs.
6. Count how many threads are still showing.
Note: Minimum engagement is three revolutions.

Rosemount 3051S Series

7. Subtract the number of threads showing (after tightening) from the total threads to calculate the revolutions engaged. Further tighten until a minimum of 3 rotations is achieved.
8. For block and bleed manifold, verify the bleed screw is installed and tightened. For two-valve manifold, verify the vent plug is installed and tightened.
9. Leak-check assembly to maximum pressure range of transmitter.

Rosemount 304 Conventional Manifold Installation Procedure

To install a 304 Conventional Manifold to a 3051S transmitter:

1. Align the Conventional Manifold with the transmitter flange. Use the four manifold bolts for alignment.
2. Finger tighten the bolts, then tighten the bolts incrementally in a cross pattern to final torque value. See "Flange Bolts" on page 2-6 for complete bolt installation information and torque values. When fully tightened, the bolts should extend through the top of the module housing plane of flange web (i.e. bolt hole) but must not contact module housing.
3. If applicable, install flange adapters on the process end of the manifold using the 1.75-in. flange bolts supplied with the transmitter.

Rosemount 305 and 304 Manifold Styles

The Rosemount 305 Integral Manifold is available in two styles: Coplanar and Traditional. The traditional 305 Integral Manifold can be mounted to most primary elements with mounting adapters.

Figure 2-15. Rosemount 305
Manifold Styles



The Rosemount 304 comes in two basic styles: Traditional (flange x flange and flange x pipe) and Wafer. The 304 traditional manifold comes in two, three, and five-valve configurations. The 304 wafer manifold comes in three and five-valve configurations.

Figure 2-16. Rosemount 304
Manifold Styles

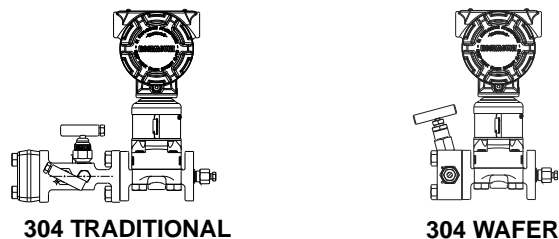

Manifold Operation

⚠ Improper installation or operation of manifolds may result in process leaks, which may cause death or serious injury.

Always perform a zero trim on the transmitter/manifold assembly after installation to eliminate any shift due to mounting effects. See Section 4 Operation and Maintenance, “Sensor Trim Overview” on page 4-5.

Three and five-valve configurations shown:

In normal operation the two block valves between the process and instrument ports will be open and the equalizing valve will be closed.

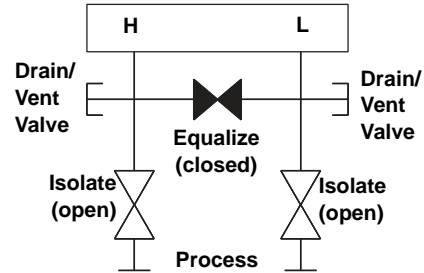

1. To zero the 3051S, close the block valve to the low pressure (downstream) side of the transmitter first.

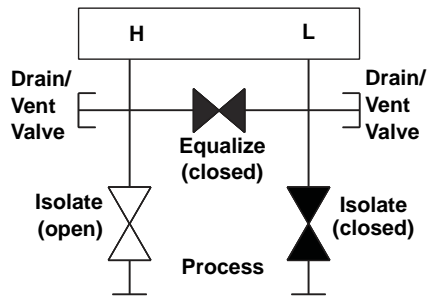

2. Open the center (equalize) valve to equalize the pressure on both sides of the transmitter. The manifold valves are now in the proper configuration for zeroing the transmitter.

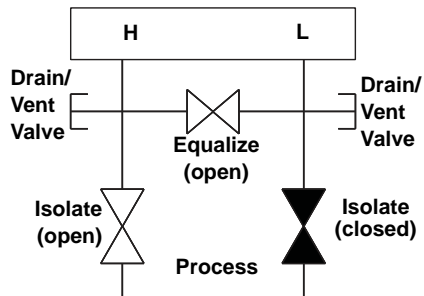

3. After zeroing the transmitter, close the equalizing valve.

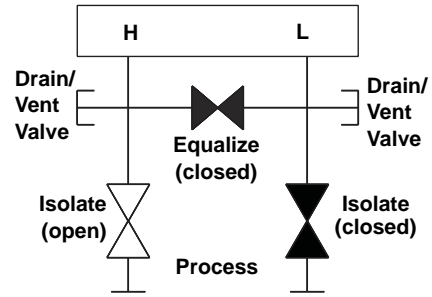

4. Open the block valve on the low pressure side of the transmitter to return the transmitter to service.

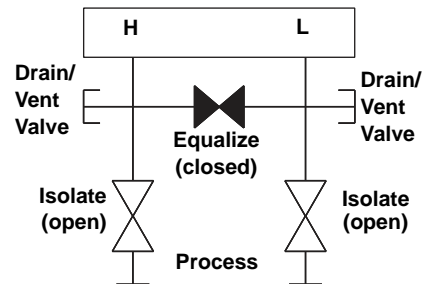

Five-valve Natural Gas configurations shown:

In normal operation, the two block valves between the process and instrument ports will be open, and the equalizing valves will be closed.

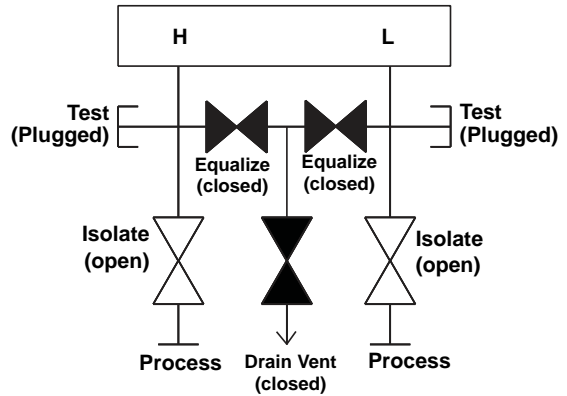

1. To zero the 3051S, first close the block valve on the low pressure (downstream) side of the transmitter.

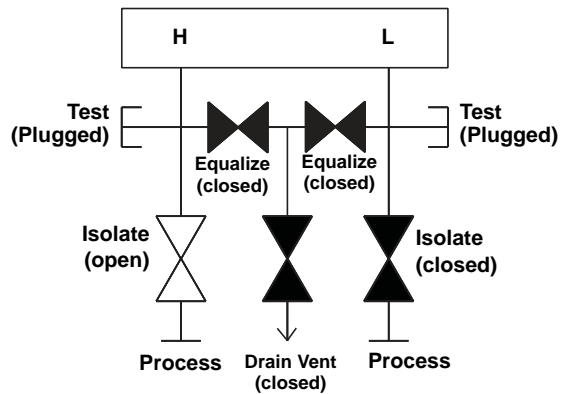

NOTE

Do not open the low side equalize valve before the high side equalize valve. Doing so will overpressure the transmitter.

2. Open the equalize valve on the high pressure (upstream) side of the transmitter.

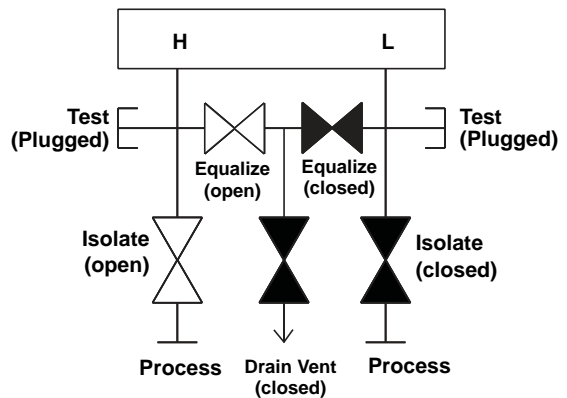

- Open the equalize valve on the low pressure (downstream) side of the transmitter. The manifold is now in the proper configuration for zeroing the transmitter.

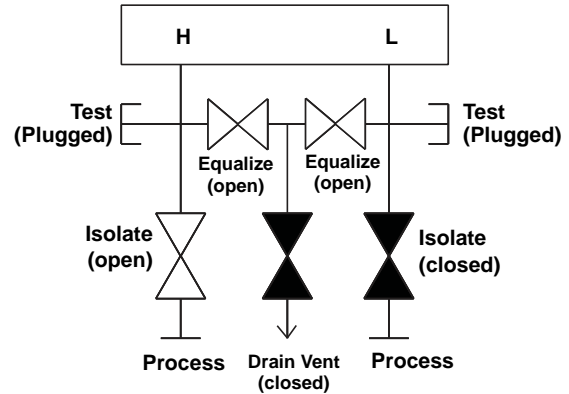

- After zeroing the transmitter, close the equalize valve on the low pressure (downstream) side of the transmitter.

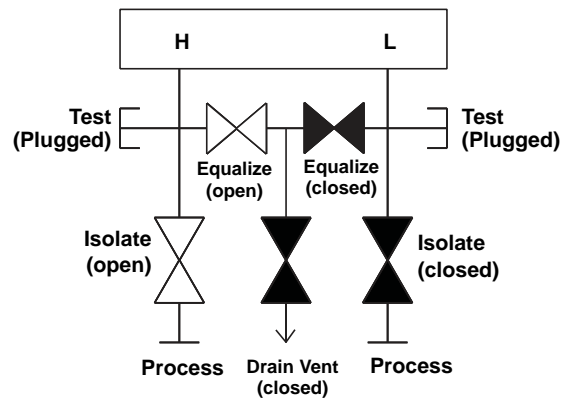

- Close the equalize valve on the high pressure (upstream) side.

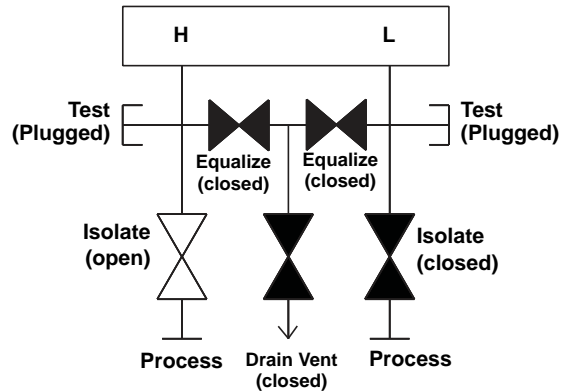

- Finally, to return the transmitter to service, open the low side isolation valve.

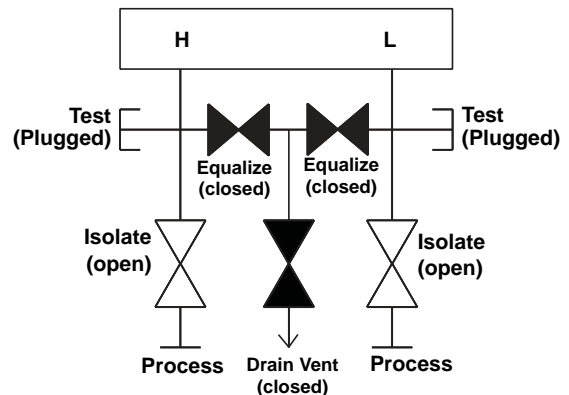

Section 3 Configuration

Overview	page 3-1
Safety Messages	page 3-1
Commissioning on the Bench with HART	page 3-2
Review Configuration Data	page 3-4
Field Communicator	page 3-5
Check Output	page 3-12
Basic Setup	page 3-13
LCD Display	page 3-17
Detailed Setup	page 3-18
Diagnostics and Service	page 3-25
Advanced Functions for HART Protocol	page 3-27
Multidrop Communication	page 3-30

OVERVIEW

This section contains information on commissioning and tasks that should be performed on the bench prior to installation.

Instructions for performing configuration functions are given for Field Communicator version 3.3 and AMS version 7.0. For convenience, Field Communicator fast key sequences are labeled “Fast Keys” for each software function below the appropriate headings.

Example Software Function

Traditional Fast Keys	1, 2, 3, etc.
Device Dashboard Fast Keys	1, 2, 3, etc.

SAFETY MESSAGES

Procedures and instructions in this section may require special precautions to ensure the safety of the personnel performing the operations. Information that raises potential safety issues is indicated by a warning symbol (⚠). Refer to the following safety messages before performing an operation preceded by this symbol.

Warnings

⚠ WARNING

Explosions can result in death or serious injury.

- Do not remove the transmitter covers in explosive environments when the circuit is live.
- Transmitter covers must be fully engaged to meet explosionproof requirements.
- Before connecting a communicator in an explosive atmosphere, make sure the instruments in the loop are installed in accordance with intrinsically safe or nonincendive field wiring practices.

Electrical shock can result in death or serious injury.

- Avoid contact with the leads and terminals. High voltage that may be present on leads can cause electrical shock.

Rosemount 3051S Series

COMMISSIONING ON THE BENCH WITH HART

Commissioning consists of testing the transmitter and verifying transmitter configuration data. 3051S transmitters can be commissioned either before or after installation. Commissioning the transmitter on the bench before installation using a 375 Field Communicator or AMS ensures that all transmitter components are in working order.

 To commission on the bench, required equipment includes a power supply, a milliamp meter, and a Field Communicator or AMS. Wire equipment as shown in Figure 3-1 and Figure 3-2. Verify transmitter terminal voltage is between 10.5 - 42.4 Vdc. To ensure successful communication, a resistance of at least 250 ohms must be present between the Field Communicator loop connection and the power supply. Connect the Field Communicator leads to the terminals labeled "COMM" on the terminal block. (Connecting across the "TEST" terminals will prevent successful communication.)

Set all transmitter hardware adjustments during commissioning to avoid exposing the transmitter electronics to the plant environment after installation. Refer to "Configure Security and Alarm" on page 2-13.

When using a Field Communicator, any configuration changes made must be sent to the transmitter by using the "Send" key (F2). AMS configuration changes are implemented when the "Apply" button is clicked.

Setting the Loop to Manual

Whenever sending or requesting data that would disrupt the loop or change the output of the transmitter, set the process application loop to manual. The Field Communicator or AMS will prompt you to set the loop to manual when necessary. Acknowledging this prompt does not set the loop to manual. The prompt is only a reminder; set the loop to manual as a separate operation.

Wiring Diagrams

Bench Hook-up

Connect the bench equipment as shown in Figures 3-1 and 3-2, and turn on the Field Communicator by pressing the ON/OFF key or log into AMS. The Field Communicator or AMS will search for a HART-compatible device and indicate when the connection is made. If the Field Communicator or AMS fail to connect, it indicates that no device was found. If this occurs, refer to Section 5: Troubleshooting.

Field Hook-up

Figures 3-1 and 3-2 illustrate wiring loops for a field hook-up with a Field Communicator or AMS. The Field Communicator or AMS may be connected at "COMM" on the transmitter terminal block, across the load resistor, or at any termination point in the signal loop. Signal point may be grounded at any point or left ungrounded.

Figure 3-1. PlantWeb Wiring (4–20 mA)

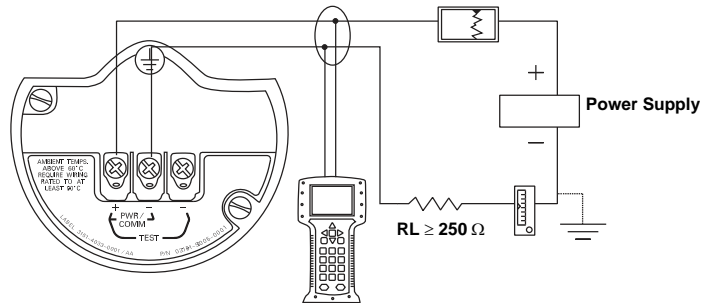
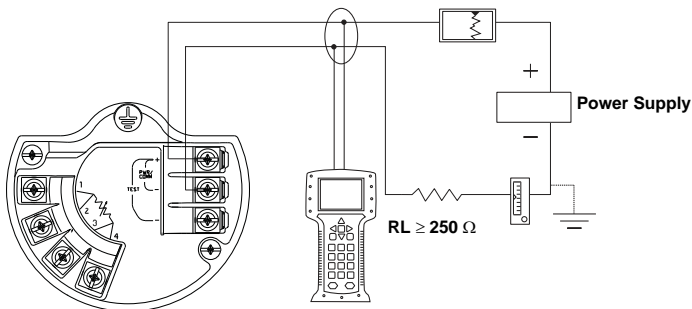

Figure 3-2. Junction Box Wiring (4–20 mA)



Rosemount 3051S Series

REVIEW CONFIGURATION DATA

NOTE

Information and procedures in this section that make use of Field Communicator fast key sequences and AMS assume that the transmitter and communication equipment are connected, powered, and operating correctly.

The following is a list of factory configurations. These can be reviewed by using the Field Communicator or AMS.

Field Communicator v3.3

Enter the fast key sequence to view the configuration data.

Traditional Fast Keys	1, 5
Device Dashboard Fast Keys	1, 7

Manufacturer "Rosemount"	O-Ring material
Transmitter model	Drain/Vent material
Measurement type	Number of diaphragm seals
Module configuration type	Seal type
Range	Remote seal isolator material
PV Unit	Seal fill fluid
PV Lower Sensor Limit (LSL)	Tag
PV Upper Sensor Limit (USL)	Date
PV Lower Range Value (LRV)	Descriptor
PV Upper Range Value (URV)	Message
PV minimum span	Write protect
Lower sensor trim point	Meter type
Upper sensor trim point	Local keys
Sensor trim calibration type	Universal revision
Transfer function	Field device revision
Damping	Software revision
Alarm direction	Hardware revision
High Alarm (Value)	Physical signal code
Low Alarm (Value)	Final assembly number
High saturation	Device ID
Low saturation	Burst mode
Alarm/Saturation type	Burst option
Sensor S/N	Poll address
Isolator material	Number req preams
Fill fluid	Multisensor device
Process connector	Command #39, EEPROM Control required
Process connector material	Distributor

AMS v7.0

Right click on the device and select "Configure" from the menu. Select the tabs to review the transmitter configuration data.

FIELD COMMUNICATOR (Version 3.3)

**Field Communicator
User Interface**

Figure 3-3. Traditional Interface

The corresponding Menu Tree can be viewed on page 3-6.
The fast key sequence can be viewed on page 3-7.

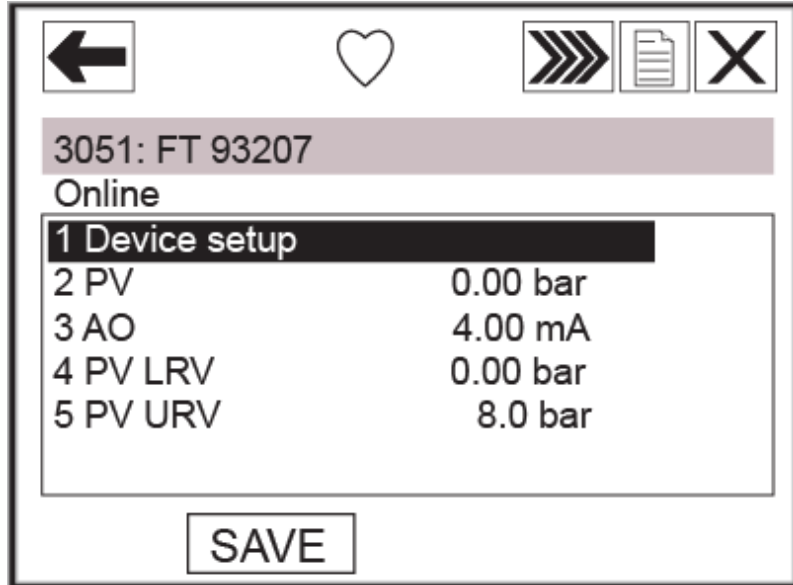
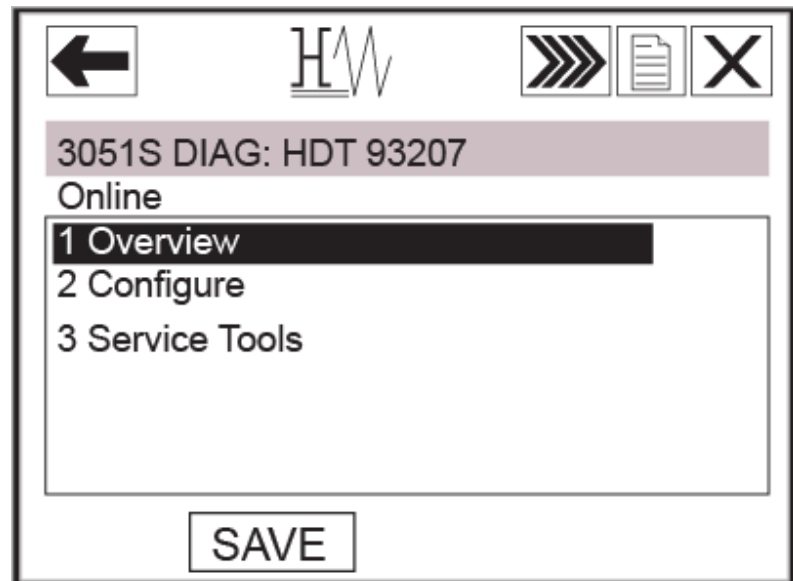

Figure 3-4. Device Dashboard

The corresponding Menu Tree can be viewed on page 3-7.
The fast key sequence can be viewed on page 3-11.



Rosemount 3051S Series

Traditional Interface Menu Tree

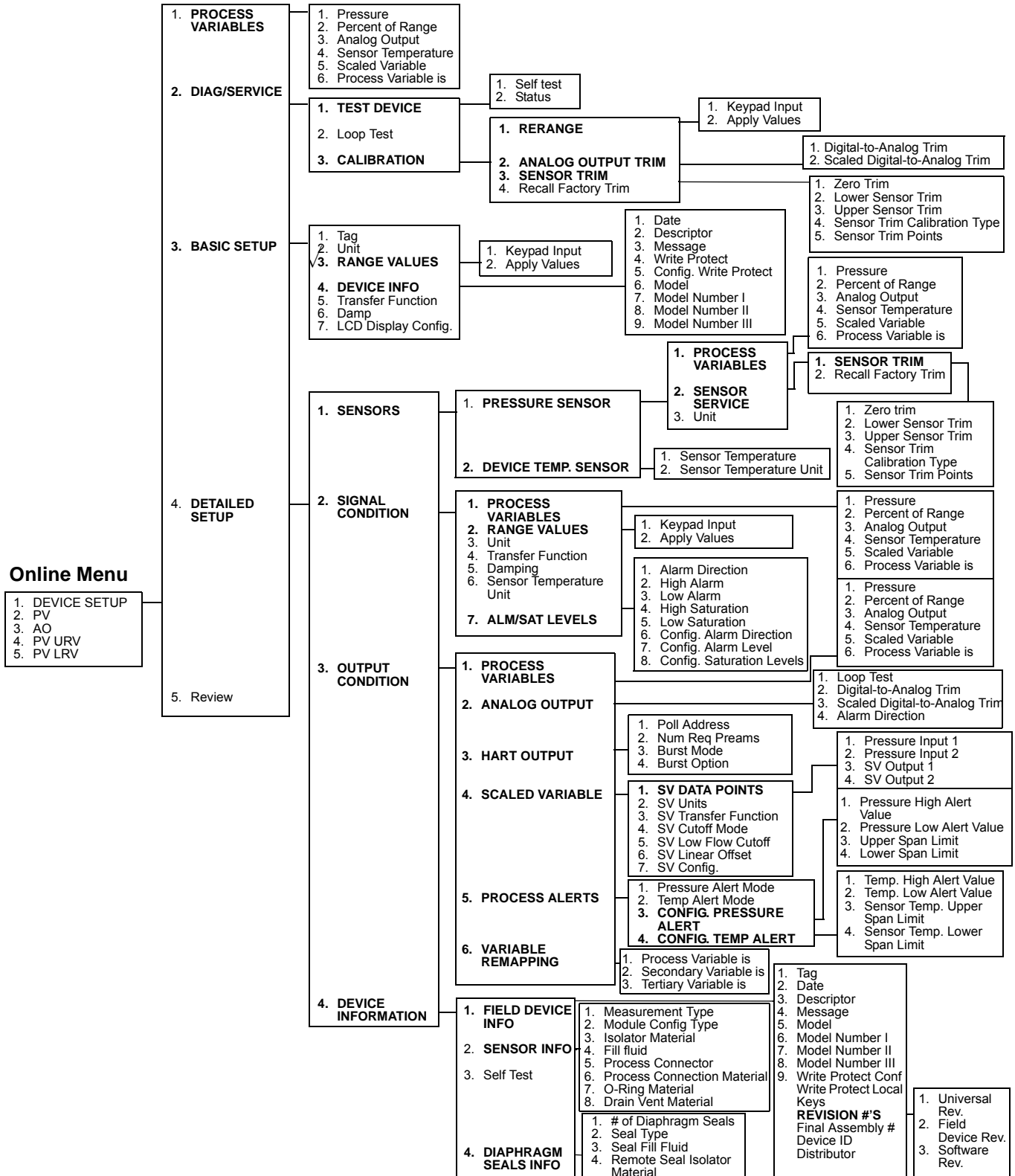

Device Dashboard Menu Tree

Figure 3-5. 3051S Device Dashboard - Overview

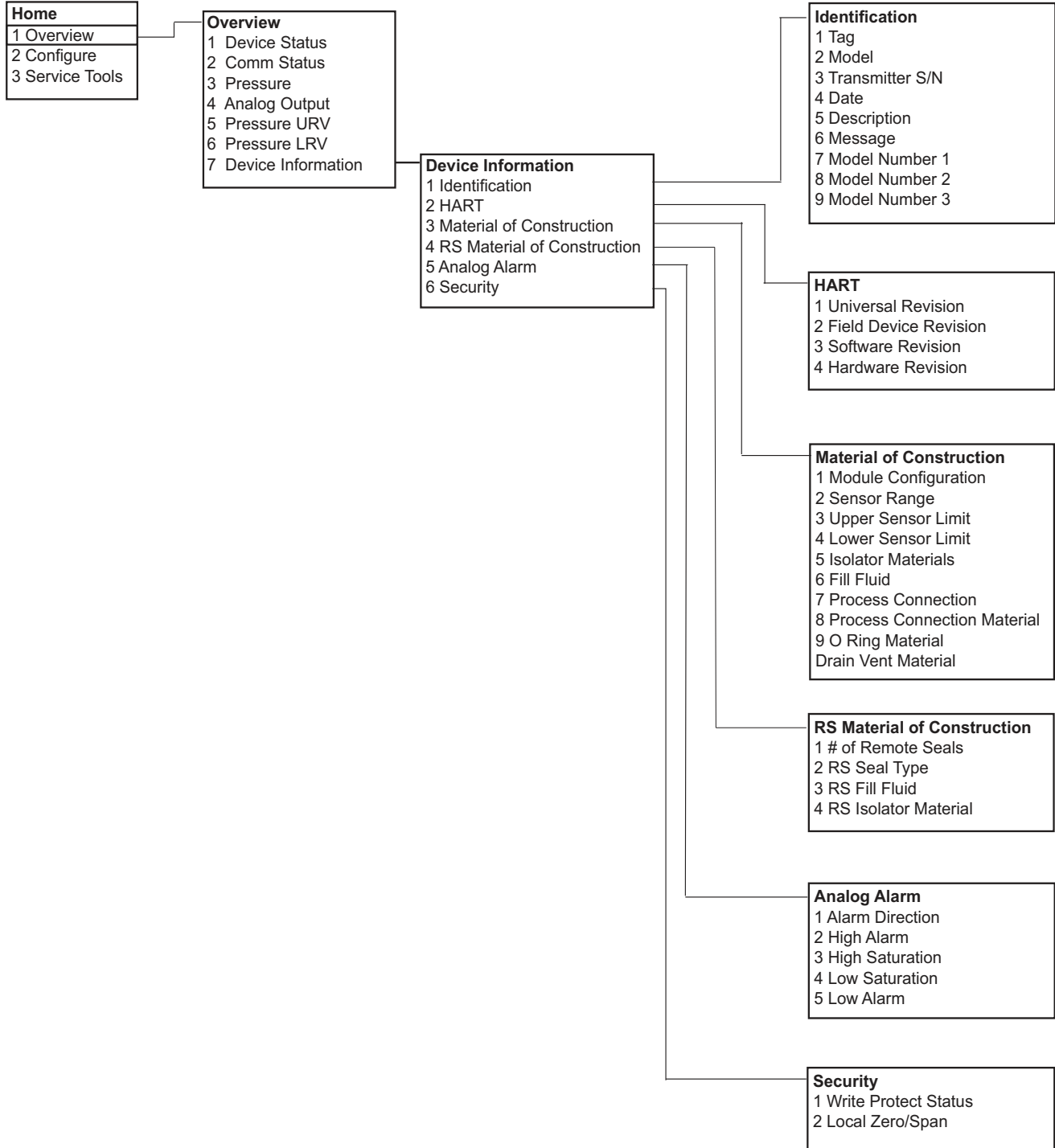

Rosemount 3051S Series

Figure 3-6. 3051S Device Dashboard - Configure

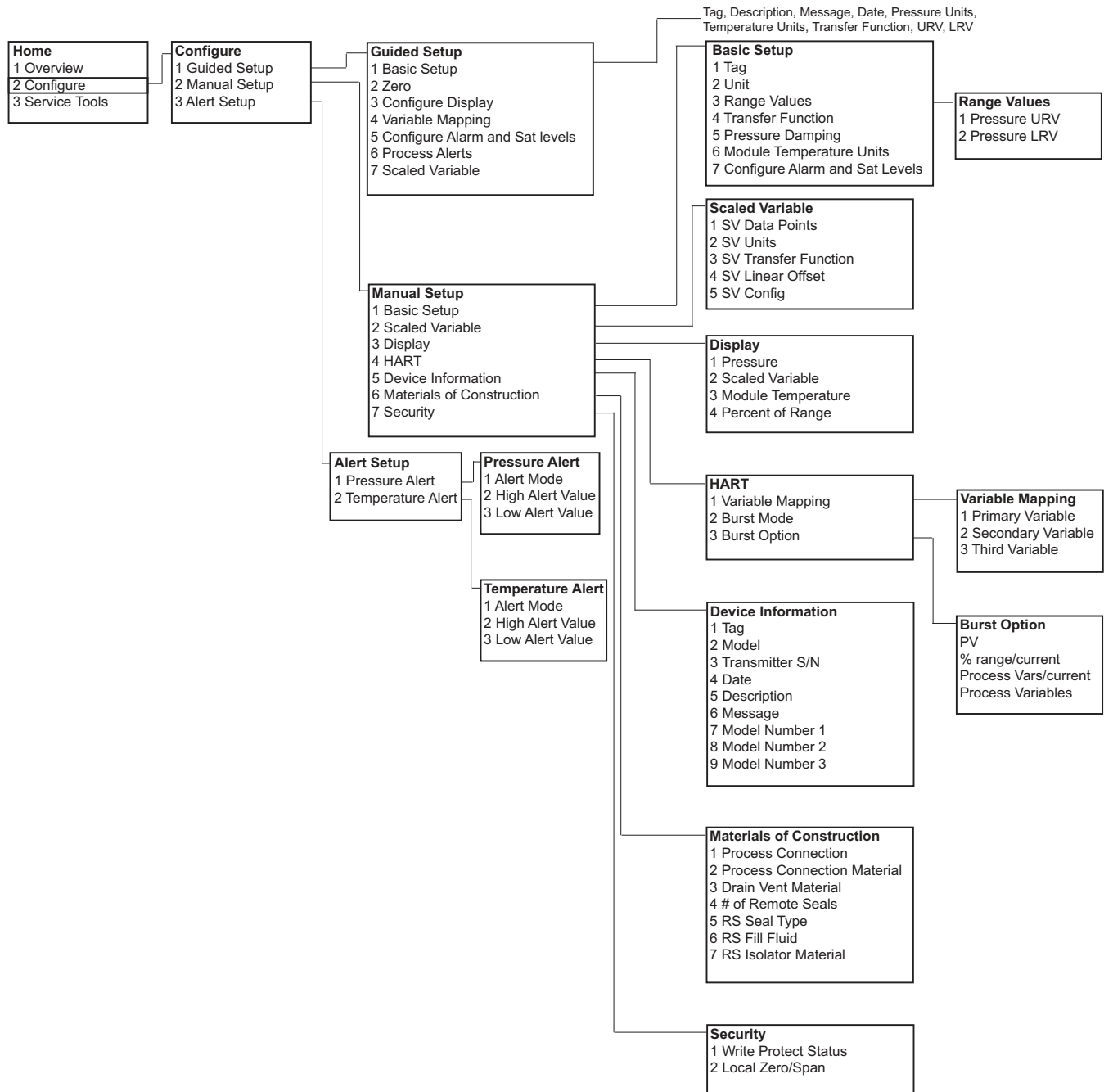
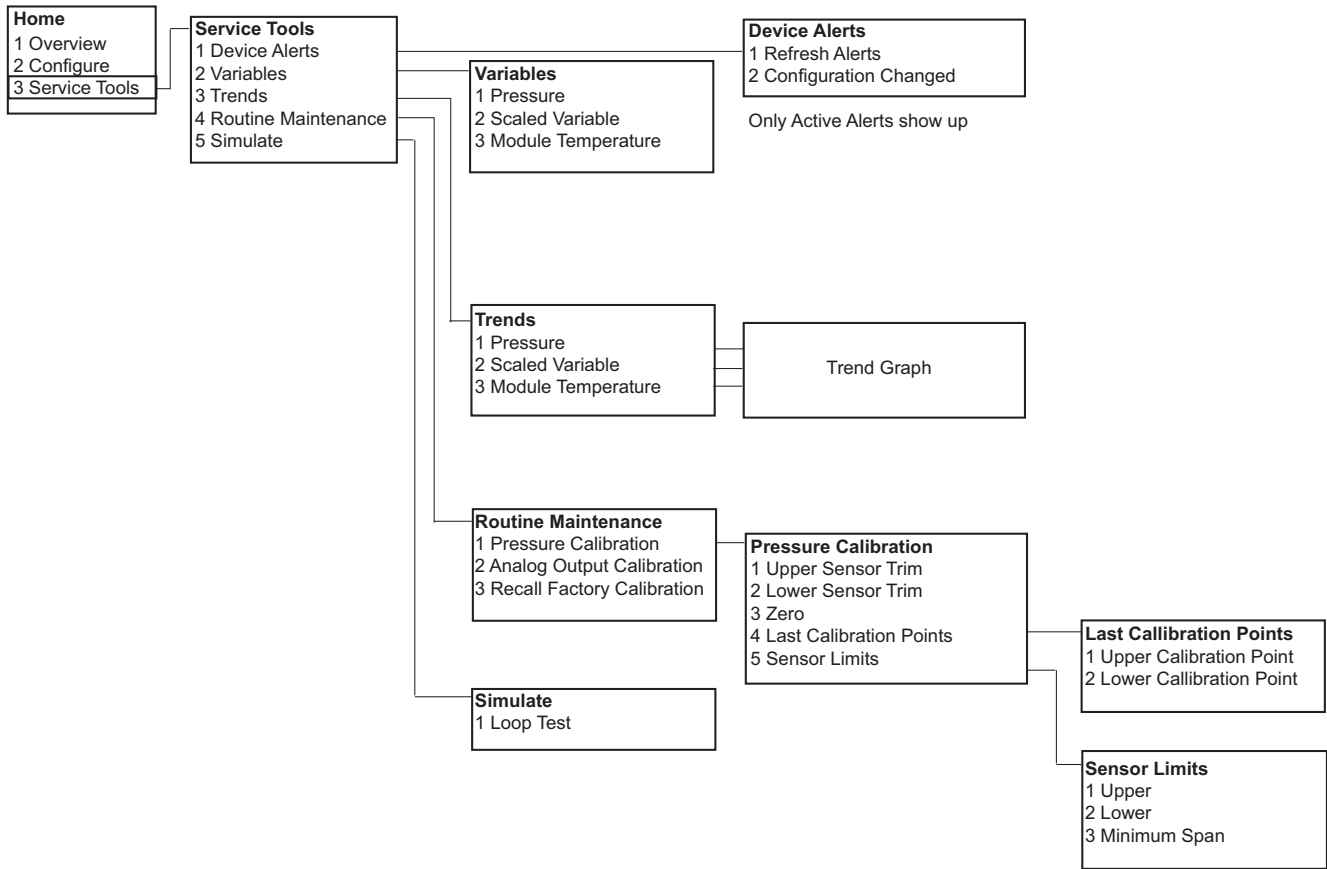

Figure 3-7. 3051S Device Dashboard - Service Tools



Rosemount 3051S Series

Traditional Fast Key Sequence

The following menu indicates fast key sequences for common functions. A check (✓) indicates the basic configuration parameters. At minimum, these parameters should be verified as part of the configuration and startup procedure.

	Function	HART Fast Key Sequence
	Alarm Level Configuration	1, 4, 2, 7, 7
	Alarm and Saturation Levels	1, 4, 2, 7
	Analog Output Alarm Direction	1, 4, 2, 7, 6
	Analog Output Trim	1, 2, 3, 2
	Burst Mode On/Off	1, 4, 3, 3, 3
	Burst Options	1, 4, 3, 3, 4
✓	Damping	1, 3, 6
	Date	1, 3, 4, 1
	Descriptor	1, 3, 4, 2
	Digital To Analog Trim (4-20 mA Output)	1, 2, 3, 2, 1
	Field Device Information	1, 4, 4, 1
	LCD Display Configuration	1, 3, 7
	Loop Test	1, 2, 2
	Lower Sensor Trim	1, 2, 3, 3, 2
	Message	1, 3, 4, 3
	Number of Requested Preambles	1, 4, 3, 3, 2
	Pressure Alert Configuration	1, 4, 3, 5, 3
	Poll Address	1, 4, 3, 3, 1
	Poll a Multidropped Transmitter	Left Arrow, 3, 1, 1
	Re-mapping	1, 4, 3, 6
	Rerange- Keypad Input	1, 2, 3, 1, 1
	Saturation Level Configuration	1, 4, 2, 7, 8
	Scaled D/A Trim (4–20 mA Output)	1, 2, 3, 2, 2
	Scaled Variable Configuration	1, 4, 3, 4, 7
	Self Test (Transmitter)	1, 2, 1, 1
	Sensor Information	1, 4, 4, 2
	Sensor Temperature	1, 1, 4
	Sensor Trim	1, 2, 3, 3
	Sensor Trim Points	1, 2, 3, 3, 5
	Status	1, 2, 1, 2
✓	Tag	1, 3, 1
	Temperature Alert Configuration	1, 4, 3, 5, 4
✓	Transfer Function (Setting Output Type)	1, 3, 5
	Transmitter Security (Write Protect)	1, 3, 4, 5
✓	Units (Process Variable)	1, 3, 2
	Upper Sensor Trim	1, 2, 3, 3, 3
	Zero Trim	1, 2, 3, 3, 1

Device Dashboard Fast Key Sequence

The following menu indicates fast key sequences for common functions. A check (✓) indicates the basic configuration parameters. At minimum, these parameters should be verified as part of the configuration and startup procedure.

	Function	Fast Key Sequence
	Alarm and Saturation Levels	1,4,5
	Alarm Level Configuration	2,2,1,7
	Analog Output Alarm Direction	1,4,5,1
	Burst Mode Control	2,2,4,2
	Burst Option	2,2,4,3
	Custom Display Configuration	2,1,3
✓	Damping	2,2,1,5
	Date	2,2,5,4
	Descriptor	2,2,5,5
	Digital to Analog Trim (4 - 20mA Output)	3,4,2
	Disable Zero & Span Adjustment	2,2,7,2
	Field Device Information	1,7
	LCD Display Configuration	2,2,3
	Loop Test	3,5,1
	Lower Sensor Trim	3,4,1,2
	Message	2,2,5,6
	Module Temperature/Trend	3,3,3
	Poll Address	1,2
	Pressure Alert Configuration	2,3,1
	Range Values	2,2,1,3
	Re-mapping	2,2,4,1
	Rerange - Keypad Input	1,5
	Rerange with Keypad	2,2,1,3
	Saturation Level Configuration	2,2,1,7
	Scaled D/A Trim (4 - 20mA Output)	3,4,2
	Scaled Variable Configuration	2,2,7
	Sensor Information	1,7,3
	Sensor Trim	3,4,1
	Sensor Trim Points	3,4,1,4
✓	Tag	2,2,5,1
	Temperature Alert Configuration	2,3,2
✓	Transfer Function (Setting Output Type)	2,2,1,4
	Transmitter Security (Write Protect)	2,2,7,1
✓	Units (Process Variable)	2,2,1,2
	Upper Sensor Trim	3,4,1,1
	Zero Trim	3,4,1,3

Rosemount 3051S Series

CHECK OUTPUT

Before performing other transmitter on-line operations, review the digital output parameters to ensure that the transmitter is operating properly and is configured to the appropriate process variables.

Process Variables

Traditional Fast Keys	1, 1
Device Dashboard Fast Keys	3, 2

The process variables for the 3051S provide transmitter output, and are continuously updated. The pressure reading in both engineering units and percent of range will continue to track with pressures outside of the defined range from the lower to the upper range limit of the SuperModule.

Field Communicator v3.3

The process variable menu displays the following process variables:

- Pressure
- Percent of range
- Analog output
- Module temperature
- Scaled Variable (SV)
- Primary Variable (PV)

NOTE

Regardless of the range points, the 3051S will measure and report all readings within the digital limits of the sensor. For example, if the 4 and 20 mA points are set to 0 and 10 inH₂O, and the transmitter detects a pressure of 25 inH₂O, it digitally outputs the 25 inH₂O reading and a 250% of span reading. However, there may be up to ±5.0% error associated with output outside of the range points.

AMS v7.0

Right click on the device and select “Process Variables...” from the menu. The process variable screen displays the following process variables:

- Pressure
- Percent of range
- Analog output
- Module temperature
- Scaled Variable (SV)
- Primary Variable (PV)

Module Temperature

Traditional Fast Keys	1, 1, 4
Device Dashboard Fast Keys	3, 2, 3

The 3051S contains a temperature sensor near the pressure sensor in the SuperModule. When reading this temperature, keep in mind the sensor is not a process temperature reading.

Field Communicator v3.3

Enter the fast key sequence “Module Temperature” to view the sensor temperature reading.

AMS v7.0

Right click on the device and select “Process Variables...” from the menu. “Module Temp” is the sensor temperature reading.

BASIC SETUP

Set Process Variable Units

Traditional Fast Keys	1, 3, 2
Device Dashboard Fast Keys	2, 2, 1, 2

The PV Unit command sets the process variable units to allow you to monitor your process using the appropriate units of measure.

Field Communicator v3.3

Enter the fast key sequence "Set Process Variable Units." Select from the following engineering units:

- inH₂O
- inHg
- ftH₂O
- mmH₂O
- mmHg
- psi
- bar
- mbar
- g/cm²
- kg/cm²
- Pa
- kPa
- torr
- atm
- MPa
- inH₂O at 4 °C
- mmH₂O at 4 °C

AMS v7.0

Right click on the device and select "Configure" from the menu. In the Basic Setup tab, use "Unit" drop down menu to select units.

Set Output (Transfer function)

Traditional Fast Keys	1, 3, 5
Device Dashboard Fast Keys	2, 2, 1, 4

The 3051S has two output settings: Linear and Square Root. Activate the square root output option to make analog output proportional to flow. As input approaches zero, the 3051S automatically switches to linear output in order to ensure a more smooth, stable output near zero (see Figure 3-8).

From 0 to 0.6 percent of the ranged pressure input, the slope of the curve is unity ($y = x$). This allows accurate calibration near zero. Greater slopes would cause large changes in output (for small changes at input). From 0.6 percent to 0.8 percent, curve slope equals 42 ($y = 42x$) to achieve continuous transition from linear to square root at the transition point.

NOTE

If low flow cutoff configuration is desired, use "Scaled Variable Configuration" on page 3-21 to configure square root and "Re-mapping" on page 3-24 to map Scaled Variable as the primary variable.

If Scaled Variable is mapped as the primary variable and square root mode is selected, ensure transfer function is set to linear.

Field Communicator v3.3

Enter the fast key sequence "Set Output (Transfer function)."

AMS v7.0

Right click on the device and select "Configure" from the menu.

1. In the Basic Setup tab, use "Xfer fnctn" drop down menu to select output, click **Apply**.
2. After carefully reading the warning provided, select **yes**.

Rosemount 3051S Series

Figure 3-8. Square Root Output
Transition Point

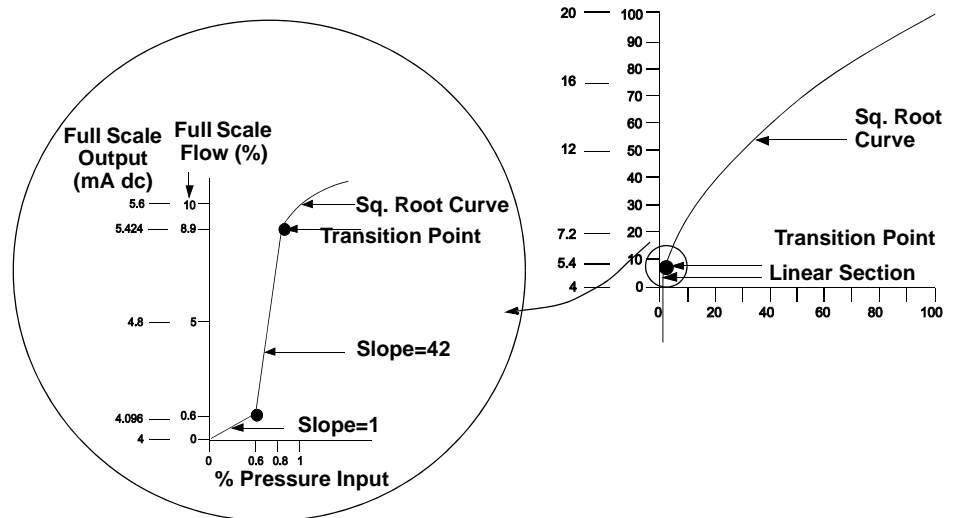

NOTE

For a flow turndown of greater than 10:1 it is not recommended to perform a square root extraction in the transmitter. Instead, perform the square root extraction in the system. Alternatively, you can configure Scaled Variable for square root output. This configuration allows you to select a low flow cutoff value, which will work best for the application. If low flow cutoff configuration is desired, use “Scaled Variable Configuration” on page 3-21 to configure square root and “Re-mapping” on page 3-24 to map Scaled Variable as the primary variable.

Rerange

The Range Values command sets the 4 and 20 mA points (lower and upper range values). In practice, you may reset the transmitter range values as often as necessary to reflect changing process conditions. Changing the lower or upper range point results in similar changes to the span. For a complete listing of Range & Sensor limits, refer to the “Range & Sensor Limits” table on page A-6.

NOTE

Transmitters are shipped from Rosemount Inc. fully calibrated per request or by the factory default of full scale (span = upper range limit.)

Select from one of the methods below to rerange the transmitter. Each method is unique; examine all options closely before deciding which method works best for your process.

- Rerange with a Field Communicator only.
- Rerange with a pressure input source and a Field Communicator.
- Rerange with a pressure input source and the local zero and span buttons (option D1).
- Rerange with AMS only.
- Rerange with a pressure input source and AMS.

NOTE

If the transmitter security jumper/switch is **ON**, adjustments to the zero and span will not be able to be made. Refer to “Configure Security and Alarm” on page 2-13 for security information.

Rerange with a Field Communicator v3.3 Only

Traditional Fast Keys	1, 2, 3, 1, 1
Device Dashboard Fast Keys	1, 5

The easiest and most popular way to rerange is to use the Field Communicator only. This method changes the values of the analog 4 and 20 mA points independently without a pressure input.

From the **HOME** screen, enter the fast key sequence “Rerange with a Communicator Only.”

1. At “Keypad Input” select 1 and use the keypad to enter lower range value.
2. From “Keypad Input” select 2 and use the keypad to enter upper range value.

Rerange with a Pressure Input Source and Field Communicator v3.3

Traditional Fast Keys	1, 2, 3, 1, 2
Device Dashboard Fast Keys	3, 4, 1

Reranging using the Field Communicator and a pressure source or process pressure is a way of reranging the transmitter when specific 4 and 20 mA points are unknown.

NOTE

The span is maintained when the 4 mA point is set. The span changes when the 20 mA point is set. If the lower range point is set to a value that causes the upper range point to exceed the sensor limit, the upper range point is automatically set to the sensor limit, and the span is adjusted accordingly.

1. From the **HOME** screen, enter the fast key sequence “Rerange with a Pressure Input Source and a Field Communicator” to configure lower and upper range values and follow the on-line instructions.

Rosemount 3051S Series

Rerange with a Pressure Input Source and the Local Zero and Span buttons (option D1)

Reranging using the local zero and span adjustments and a pressure source is a way of reranging the transmitter.

1. Using a pressure source with an accuracy three to ten times the desired calibrated accuracy, apply a pressure equivalent to the lower range value to the high side of the transmitter.
2. Push and hold the zero adjustment button for at least two seconds but no longer than ten seconds.
3. Apply a pressure equivalent to the upper range value to the high side of the transmitter.
4. Push and hold the span adjustment button for at least two seconds but no longer than ten seconds.

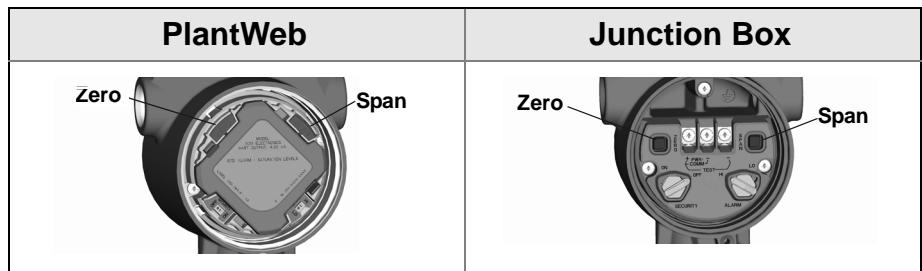

Rerange with AMS v7.0 only

Right click on the device and select “Configure” from the menu. In the Basic Setup tab, locate the Analog Output box and perform the following procedure:

1. Enter the lower range value (LRV) and the upper range value (URV) in the fields provided. Click **Apply**.
2. After carefully reading the warning provided, select **yes**.

Rerange with a Pressure Input Source and AMS v7.0

Right click on the device, select “Calibrate”, then “Apply values” from the menu.

1. Select **Next** after the control loop is set to manual.
2. From the “Apply Values” menu, follow the on-line instructions to configure lower and upper range values.
3. Select **Exit** to leave the “Apply Values” screen.
4. Select **Next** to acknowledge the loop can be returned to automatic control.
5. Select **Finish** to acknowledge the method is complete.

Damping

Traditional Fast Keys	1, 3, 6
Device Dashboard Fast Keys	2, 2, 1, 5

The Damp command introduces a delay in processing which increases the response time of the transmitter; smoothing variations in output readings caused by rapid input changes. Determine the appropriate damp setting based on the necessary response time, signal stability, and other requirements of the loop dynamics of your system. The damping value of your device is user selectable from 0 to 60 seconds. The current damping value can be determined by executing the Field Communicator fast keys or going to “Configure” in AMS.

Field Communicator v3.3

Enter the fast key sequence “Damping.”

AMS v7.0

Right click on the device and select “Configure” from the menu.

1. In the “Basic Setup” tab, enter the damping value in the “Damp” field, click **Apply**.
2. After carefully reading the warning provided, select **yes**.

LCD DISPLAY

The LCD display connects directly to the interface/electronics board which maintains direct access to the signal terminals. The display indicates output and abbreviated diagnostic messages. A display cover is provided to accommodate the display.

The LCD display features a four-line display and a 0-100% scaled bar graph. The first line of five characters displays the output description, the second line of seven digits displays the actual value, the third line of six characters displays engineering units and the fourth line displays “Error” when the transmitter is in alarm. The LCD display can also display diagnostic messages.

LCD Display Configuration with Field Communicator v3.3

Traditional Fast Keys	1, 3, 7
Device Dashboard Fast Keys	2, 2, 3

The factory default LCD display setting is engineering units. The Meter Options command allows customization of the LCD display to suit application requirements. The LCD display will alternate between the selected items (up to four may be chosen):

- Pressure (Engineering Units)
- Percent of Range
- Scaled Variable
- Temperature

AMS v7.0

Right click on the device and select “Configure” from the menu.

1. In the “LCD” tab, select the desired options to suit your application needs, click **Apply**.
2. After carefully reading the warning provided, select **yes**.

Rosemount 3051S Series

DETAILED SETUP

Failure Mode Alarm and Saturation

3051S transmitters automatically and continuously perform self-diagnostic routines. If the self-diagnostic routines detect a failure, the transmitter drives the output to configured alarm values. The transmitter will also drive the output to configured saturation values if the applied pressure goes outside the 4-20 mA range values.

The transmitter will drive its output low or high based on the position of the failure mode alarm jumper, see “Configure Security and Alarm” on page 2-13.

NOTE

The failure mode alarm direction can also be configured using the Field Communicator or AMS.

3051S transmitters have three configurable options for failure mode alarm and saturation levels:

- Rosemount (Standard), see Table 3-1.
- NAMUR, see Table 3-2.
- Custom, see Table 3-3.

Table 3-1. Rosemount (Standard) Alarm and Saturation Values

Level	4–20 mA Saturation	4–20 mA Alarm
Low	3.9 mA	≤ 3.75 mA
High	20.8 mA	≥ 21.75 mA

Table 3-2. NAMUR-Compliant Alarm and Saturation Values

Level	4–20 mA Saturation	4–20 mA Alarm
Low	3.8 mA	≤ 3.6 mA
High	20.5 mA	≥ 22.5 mA

Table 3-3. Custom Alarm and Saturation Values

Level	4–20 mA Saturation	4–20 mA Alarm
Low	3.7 mA — 3.9 mA	3.4 mA — 3.8 mA
High	20.1 mA — 21.5 mA	20.2 mA — 23.0 mA

Failure mode alarm and saturation levels can be configured using a Field Communicator or AMS, see “Alarm and Saturation Level Configuration” on page 3-19. Per Table 3-3, custom alarm and saturation levels can be configured between 3.6 mA and 3.9 mA for low values and between 20.1 mA and 23 mA for high values. The following limitations exist for custom levels:

- Low alarm level must be less than the low saturation level
- High alarm level must be higher than the high saturation level
- High saturation level must not exceed 21.5 mA
- Alarm and saturation levels must be separated by at least 0.1 mA

The Field Communicator or AMS will provide an error message if a configuration rule is violated.

Alarm and Saturation Level Configuration

Traditional Fast Keys	1, 4, 2, 7
Device Dashboard Fast Keys	2, 2, 1, 7

To configure alarm and saturation levels with a Field Communicator or AMS perform the following procedure:

Field Communicator v3.3

1. From the **HOME** screen, follow the fast key sequence.
2. Select 7, **Config. Alarm Level** to configure alarm levels.
3. Select **OK** after setting the control loop to manual.
4. Select **OK** to acknowledge current settings.
5. Select desired setting, if "OTHER" is selected enter HI and LO custom values.
6. Select **OK** to acknowledge the loop can be returned to automatic control.
7. Select 8, **Config. Sat. Levels** to configure saturation levels.
8. Repeat steps 3-6 to configure saturation levels.

AMS v7.0

Right click on the device, select "Device Configuration", then select "Alarm/Saturation Levels," then "Alarm Levels" from the menu.

1. Click **Next** after setting the control loop to manual.
2. Click **Next** after acknowledging the current alarm levels.
3. Select the desired alarm settings: NAMUR, Rosemount, Other
4. If "Other" is selected, enter desired "HI Value" and "LO Value" custom values.
5. Click **Next** to acknowledge new alarm levels.
6. Select **Next** to acknowledge the loop can be returned to automatic control.
7. Select **Finish** to acknowledge the method is complete.
8. Right click on the device, select "Device Configuration," then select "Alarm/Saturation Levels," then "Saturation Levels" from the menu.
9. Repeat steps 2 - 8 to configure saturation levels.

Alarm and Saturation Levels for Burst Mode

Transmitters set to burst mode handle saturation and alarm conditions differently.

Alarm Conditions:

- Analog output switches to alarm value
- Primary variable is burst with a status bit set
- Percent of range follows primary variable
- Temperature is burst with a status bit set

Saturation:

- Analog output switches to saturation value
- Primary variable is burst normally
- Temperature is burst normally

Rosemount 3051S Series

Alarm and Saturation Values for Multidrop Mode

Transmitters set to multidrop mode handle saturation and alarm conditions differently.

Alarm Conditions:

- Primary variable is sent with a status bit set
- Percent of range follows primary variable
- Temperature is sent with a status bit set

Saturation:

- Primary variable is sent normally
- Temperature is sent normally

Alarm Level Verification

The transmitter alarm level should be verified before returning the transmitter to service if the following changes are made:

- Replacement of electronics board, SuperModule, or LCD display
- Alarm and saturation level configuration

This feature is also useful in testing the reaction of the control system to a transmitter in an alarm state. To verify the transmitter alarm values, perform a loop test and set the transmitter output to the alarm value (see Table 3-1, Table 3-2, and Table 3-3 on page 3-18, and “Loop Test” on page 3-26).

Process Alerts

Traditional Fast Keys	1, 4, 3, 5
Device Dashboard Fast Keys	2, 3

Process alerts allow the user to configure the transmitter to output a HART message when the configured data point is exceeded. Process alerts can be set for pressure, temperature, or both. A process alert will be transmitted continuously if the pressure or temperature set points are exceeded and the alert mode is **ON**. An alert will be displayed on a Field Communicator, AMS status screen or in the error section of the LCD display. The alert will reset once the value returns within range.

NOTE

HI alert value must be higher than the LO alert value. Both alert values must be within the pressure or temperature sensor limits.

Field Communicator v3.3

To configure the process alerts with a Field Communicator, perform the following procedure:

1. From the **HOME** screen, follow the fast key sequence “Process Alerts.”
2. Select 3, “Config Press Alerts” to configure the pressure alert.
Select 4, “Config Temp Alerts” to configure the temperature alerts.
3. Use the right arrow key to configure the HI and LO alert values.
4. Use the left arrow to move back to the process alert menu.
Select 1, “Press Alert Mode” to turn on the pressure alert mode.
Select 2, “Temp Alert Mode” to turn on the temperature alert mode.

AMS v7.0

Right click on the device and select “Configure” from the menu.

1. In the “Analog Output” tab, locate the “Configuration Pressure Alerts” box, enter “Press Hi Alert Val” and “Press Lo Alert Val” to configure the pressure alerts.
2. Configure “Press Alert Mode” to “ON” or “OFF” using the drop down menu.
3. In the “Configuration Temperature Alerts” box, enter “Temp Hi Alert Val” and “Temp Lo Alert Val” to configure the temperature alerts.
4. Configure “Temp Alert Mode” to “ON” or “OFF” using the drop down menu and click **Apply**.
5. After carefully reading the warning provided, select **yes**.

Scaled Variable Configuration

Traditional Fast Keys	1, 4, 3, 4, 7
Device Dashboard Fast Keys	2, 2, 2

The scaled variable configuration allows the user to create a relationship/conversion between the pressure units and user-defined/custom units. There are two use cases for scaled variable. The first use case is to allow custom units to be displayed on the transmitter's LCD display. The second use case is to allow custom units to drive the transmitter's 4-20 mA output.

If the user desires custom units to drive the 4-20 mA output, scaled variable must be re-mapped as the primary variable. Refer to “Re-mapping” on page 3-24.

The scaled variable configuration defines the following items:

- Scaled variable units - Custom units to be displayed.
- Scaled data options - Defines the transfer function for the application
 - a. Linear
 - b. Square root
- Pressure value position 1 - Lower known value point (possible 4 mA point) with consideration of linear offset.
- Scaled variable value position 1 - Custom unit equivalent to the lower known value point (The lower known value point may or may not be the 4 mA point.)
- Pressure value position 2 - Upper known value point (possible 20 mA point)
- Scaled variable value position 2 - Custom unit equivalent to the upper known value point (possible 20 mA point)
- Linear offset - The value required to zero out pressures effecting the desired pressure reading.
- Low flow cutoff - Point at which output is driven to zero to prevent problems caused by process noise. It is highly recommended to use the low flow cutoff function in order to have a stable output and avoid problems due to process noise at a low flow or no flow condition. A low flow cutoff value that is practical for the flow element in the application should be entered.

NOTE

If Scaled Variable is mapped as the primary variable and square root mode is selected, ensure transfer function is set to linear. Refer to “Set Output (Transfer function)” on page 3-13.

Field Communicator v3.3

To configure the scaled variable with a Field Communicator, perform the following procedure:

1. From the **HOME** screen follow the fast key sequence “Scaled Variable Configuration.”
2. Select **OK** after the control loop is set to manual.
3. Enter the scaled variable units.
 - a. Units can be up to five characters long and include A — Z, 0 — 9, -, /, %, and *. Default unit is DEFLT.
 - b. The first character is always an asterisk (*), which identifies the units displayed are scaled variable units.
4. Select scaled data options
 - a. Select linear if the relationship between PV and scaled variable units are linear. Linear prompts for two data points.
 - b. Select square root if the relationship between PV and scaled variable is square root (flow applications). Square root will prompt for one data point.
5. Enter pressure value position 1. Pressure values must be within the range of the transmitter.
 - a. (If performing a **Linear Function**) Enter the lower known value point considering any linear offset.
 - b. (If performing a **Square Root Function**) Select **OK** to acknowledge pressure value is set to zero.
6. Enter scaled variable position 1.
 - a. (If performing a **Linear Function**) Enter the lower known value point; this value must be no longer than seven digits.
 - b. (If performing a **Square Root Function**) Select **OK** to acknowledge scaled variable value is set to zero.
7. Enter pressure value position 2. Pressure values must be within the range of the transmitter.
 - a. Enter the upper known value point.
8. Enter scaled variable position 2.
 - a. (If performing a **Linear Function**) Enter custom unit equivalent to the upper known value point; this value must be no longer than seven digits.
 - b. (If performing a **Square Root Function**) Enter custom unit equivalent to the value in step 7; this value must be no longer than seven digits. Skip to step 10.
9. Enter linear offset value in scaled variable (custom) units (If performing a **Linear Function**). Skip to step 11.
10. Enter Low Flow cutoff mode (If performing a **Square Root Function**)
 - a. Select **OFF** if a low flow cutoff value is not desired.
 - b. Select **ON** if a low flow cutoff value is desired and enter this value in scaled variable (custom) units on the next screen.
11. Select **OK** to acknowledge that the loop can be returned to automatic control.

AMS v7.0

Right click on the device and select “Device Configuration” then select “SV Config” from the menu.

1. Click **Next** after setting the control loop to manual.
2. Enter desired scaled variable units in “Enter SV units” box and click **Next**.
3. Select scaled data options: Linear or Square Root and click **Next**. If square root is selected skip to Step 9.
4. Enter pressure value position 1 and click **Next**.
5. Enter scaled variable position 1 and click **Next**.
6. Enter pressure value position 2 and click **Next**.
7. Enter scaled variable position 2 and click **Next**.
8. Enter linear offset and click **Next**. Skip to Step 15.
9. Select **Next** to acknowledge that “Pressure value for position 1 is set to zero.
10. Select **Next** to acknowledged that “Square root value for position 1 is set to zero.
11. Enter pressure value for position 2 and click **Next**.
12. Enter square root value for position 2 and click **Next**.
13. Enter low flow cutoff mode: Off or On. If off is selected skip to Step 15.
14. Enter low flow cutoff value in scaled variable (custom) units and click **Next**.
15. Select **Next** to acknowledge that the loop can be returned to automatic control.
16. Select **Finish** to acknowledge the method is complete.

DP Level Example

A differential transmitter is used in a level application where the span is 188 inH₂O (200 in. * 0.94 sg). Once installed on an empty tank and taps vented, the process variable reading is -209.4 inH₂O. The process variable reading is the head pressure created by fill fluid in the capillary. Based on Figure 3-9, the Scaled Variable configuration would be as follows:

Figure 3-9. Example tank

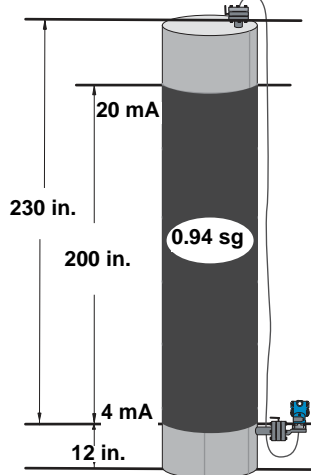

Scaled Variable units:	inches
Scaled data options:	linear
Pressure value position 1:	0 inH ₂ O (0 mbar)
Scaled Variable position 1:	12 in. (305 mm)
Pressure value position 2:	188 inH ₂ O (0.47 bar)
Scaled Variable position 2:	212 in. (5385 mm)
Linear offset:	-209.4 inH ₂ O (-0.52 bar)

Rosemount 3051S Series

DP Flow Example

A differential transmitter is used in conjunction with an orifice plate in a flow application where the differential pressure at full scale flow is 125 inH₂O. In this particular application, the flow rate at full scale flow is 20,000 gallons of water per hour. It is highly recommended to use the low flow cutoff function in order to have a stable output and avoid problems due to process noise at a low flow or no flow condition. A low flow cutoff value that is practical for the flow element in the application should be entered. In this particular example, the low flow cutoff value is 1000 gallons of water per hour. Based on this information, the Scaled Variable configuration would be as follows:

Scaled Variable units:	gal/h
Scaled data options:	square root
Pressure value position 2:	125 inH ₂ O (311 mbar)
Scaled Variable position 2:	20,000 gal/h (75,708 lt/hr)
Low Flow Cutoff:	1000 gal/h (ON)

NOTE

Pressure value position 1 and Scaled Variable position 1 are always set to zero for a flow application. No configuration of these values is required.

Re-mapping

Traditional Fast Keys	1, 4, 3, 6
Device Dashboard Fast Keys	2, 2, 4, 1

The re-mapping function allows the transmitter primary, secondary, and tertiary variables to be configured as desired. Default configuration for transmitter variables is as shown below:

Primary variable (PV) = Pressure
 Secondary variable (SV) = Temperature
 Tertiary variable (TV) = Scaled Variable

NOTE

Variable assigned as the primary variable drives the 4-20 mA analog output.

The scaled variable can be remapped as the primary variable if desired.

Field Communicator v3.3

From the **HOME** screen, enter the fast key sequence “Re-mapping.”

1. Select **OK** after the control loop is set to manual (see “Setting the Loop to Manual” on page 3-2).
2. Choose desired primary variable and select **Enter**.
3. Choose desired secondary variable and select **Enter**.
4. Select **OK** to acknowledge the tertiary variable setting.
5. Select **OK** to acknowledge that the loop can be returned to automatic control.

AMS v7.0

Right click on the device and select “Configure”.

1. In “Basic Setup” tab, locate “Variable Mapping” box.
2. Choose desired primary variable.
3. Choose desired secondary variable.
4. Choose desired tertiary variable.
5. Click **Apply** and then select **Next** to acknowledge the loop can be returned to automatic control.
6. Select **Finish** to acknowledge the method is complete.

Sensor Temperature Unit

Traditional Fast Keys	1, 4, 1, 2, 2
Device Dashboard Fast Keys	2, 2, 1, 6

The Sensor Temperature Unit command selects between Celsius and Fahrenheit units for the sensor temperature. The sensor temperature output is accessible via HART only.

Field Communicator v3.3

Enter the fast key sequence “Sensor Temperature Unit.”

AMS v7.0

Right click on the device and select “Configure” from the menu.

1. In the “Process Input” tab, use the drop down menu “Snsr temp unit” to select F (Fahrenheit) or C (Celsius). Click **Apply**.
2. Click **Next** to acknowledge send warning.
3. Select **Finish** to acknowledge the method is complete.
4. After carefully reading the warning, select **yes**.

DIAGNOSTICS AND SERVICE

Diagnostics and service functions listed below are primarily for use after field installation. The Transmitter Test feature is designed to verify that the transmitter is operating properly, and can be performed either on the bench or in the field. The Loop Test feature is designed to verify proper loop wiring and transmitter output, and should only be performed after you install the transmitter.

Rosemount 3051S Series

Loop Test

Traditional Fast Keys	1, 2, 2
Device Dashboard Fast Keys	3, 5, 1

The Loop Test command verifies the output of the transmitter, the integrity of the loop, and the operations of any recorders or similar devices installed in the loop.

Field Communicator v3.3

To initiate a loop test, perform the following procedure:

1. Connect a reference meter to the transmitter by either connecting the meter to the test terminals on the terminal block, or shunting transmitter power through the meter at some point in the loop.
2. From the **HOME** screen, enter the fast key sequence “Loop Test” to verify the output of the transmitter.
3. Select **OK** after the control loop is set to manual (see “Setting the Loop to Manual” on page 3-2).
4. Select a discrete milliamp level for the transmitter to output. At the **CHOOSE ANALOG OUTPUT** prompt select 1: 4mA, select 2: 20mA, or select 3: “Other” to manually input a value.
 - a. If you are performing a loop test to verify the output of a transmitter, enter a value between 4 and 20 mA.
 - b. If you are performing a loop test to verify alarm levels, enter the milliamp value representing an alarm state (see Table 3-1, Table 3-2, and Table 3-3 on page 3-18).
5. Check the reference meter installed in the test loop to verify that it displays the commanded output value.
 - a. If the values match, the transmitter and the loop are configured and functioning properly.
 - b. If the values do not match, the current meter may be attached to the wrong loop there may be a fault in the wiring, the transmitter may require an output trim, or the reference meter may be malfunctioning.

After completing the test procedure, the display returns to the loop test screen to choose another output value or to end loop testing.

AMS v7.0

Right click on the device and select “Diagnostics and Test,” then “Loop test” from the menu.

1. Connect a reference meter to the transmitter by either connecting the meter to the test terminals on the terminal block, or shunting transmitter power through the meter at some point in the loop.
2. Click **Next** after setting the control loop to manual.
3. Select desired analog output level. Click **Next**.
4. Click **Next** to acknowledge output being set to desired level.

5. Check the reference meter installed in the test loop to verify that it displays the commanded output value.
 - a. If the values match, the transmitter and the loop are configured and functioning properly.
 - b. If the values do not match, the current meter may be attached to the wrong loop, there may be a fault in the wiring, the transmitter may require an output trim, or the reference meter may be malfunctioning.

After completing the test procedure, the display returns to the loop test screen to choose another output value or to end loop testing.

6. Select **End** and click **Next** to end loop testing.
7. Select **Next** to acknowledge the loop can be returned to automatic control.
8. Select **Finish** to acknowledge the method is complete.

ADVANCED FUNCTIONS FOR HART PROTOCOL

Saving, Recalling, and Cloning Configuration Data

Traditional Fast Keys	left arrow, 1, 2
Device Dashboard Fast Keys	3, 4, 3

Use the cloning feature of the Field Communicator or the AMS “User Configuration” feature to configure several 3051S transmitters similarly. Cloning involves configuring a transmitter, saving the configuration data, then sending a copy of the data to a separate transmitter. Several possible procedures exist when saving, recalling, and cloning configuration data. For complete instructions refer to the Field Communicator manual (publication no. 00809-0100-4276) or AMS on-line guides. One common method is as follows:

Field Communicator v3.3

1. Confirm and apply configuration changes to the first transmitter.

NOTE

If transmitter configuration has not been modified, “SAVE” option in step 2 will be disabled

2. Save the configuration data:
 - a. Select “SAVE” from the bottom of the Field Communicator screen.
 - b. Choose to save your configuration in either the “Internal Flash” (default) or the “Configuration EM” (Configuration Expansion Module).
 - c. Enter the name for this configuration file. The default name is the transmitter tag number.
 - d. Select “SAVE”.
3. Power the receiving transmitter and connect with Field Communicator.
4. Access the HART Application menu by pressing the LEFT ARROW from the HOME/ONLINE screen.

5. Locate the saved transmitter configuration file.
 - a. Select “Offline”
 - b. Select “Saved Configuration”
 - c. Select either “Internal Flash Contents” or “Configuration EM Contents” depending on where the configuration was stored per step 2b.
6. Use the DOWN ARROW to scroll through the list of configurations in the memory module, and use the RIGHT ARROW to select and retrieve the desired configuration.
7. Select “Send” to transfer the configuration to the receiving transmitter.
8. Select “OK” after the control loop is set to manual.
9. After the configuration has been sent, select “OK” to acknowledge that the loop can be returned to automatic control.

When finished, the Field Communicator informs you of the status. Repeat steps 3 through 9 to configure another transmitter.

NOTE

The transmitter receiving cloned data must have the same software version (or later) as the original transmitter.

AMS v7.0 creating a Reusable Copy

To create a reusable copy of a configuration perform the following procedure:

1. Completely configure the first transmitter.
2. Select View then User Configuration View from the menu bar (or click the toolbar button).
3. In the User Configuration window, right click and select New from the context menu.
4. In the New window, select a device from the list of templates shown, and click **OK**.
5. The template is copied into the User Configurations window, with the tag name highlighted; rename it as appropriate and press **Enter**.

NOTE

A device icon can also be copied by dragging and dropping a device template or any other device icon from AMS Explorer or Device Connection View into the User Configurations window.

The “Compare Configurations” window appears, showing the Current values of the copied device on one side and mostly blank fields on the other (User Configuration) side.

6. Transfer values from the current configuration to the user configuration as appropriate or enter values by typing them into the available fields.
7. Click Apply to apply the values, or click **OK** to apply the values and close the window.

AMS v7.0 Applying a User Configuration

Any amount of user configurations can be created for the application. They can also be saved, and applied to connected devices or to devices in the Device List or Plant Database.

NOTE

When using AMS Revision 6.0 or later, the device to which the user configuration is applied must be the same model type as the one created in the user configuration. When using AMS Revision 5.0 or earlier, the same model type and revision number are required.

To apply a user configuration perform the following procedure:

1. Select the desired user configuration in the User Configurations window.
2. Drag the icon onto a like device in AMS Explorer or Device Connection View. The Compare Configurations window opens, showing the parameters of the target device on one side and the parameters of the user configuration on the other.
3. Transfer parameters from the user configuration to the target device as desired, Click **OK** to apply the configuration and close the window.

Burst Mode

Traditional Fast Keys	1, 4, 3, 3, 3
Device Dashboard Fast Keys	2, 2, 4, 2

When configured for burst mode, the 3051S provides faster digital communication from the transmitter to the control system by eliminating the time required for the control system to request information from the transmitter. Burst mode is compatible with the analog signal. Because the HART protocol features simultaneous digital and analog data transmission, the analog value can drive other equipment in the loop while the control system is receiving the digital information. Burst mode applies only to the transmission of dynamic data (pressure and temperature in engineering units, pressure in percent of range, and/or analog output), and does not affect the way other transmitter data is accessed.

Access to information other than dynamic transmitter data is obtained through the normal poll/response method of HART communication. A Field Communicator, AMS or the control system may request any of the information that is normally available while the transmitter is in burst mode. Between each message sent by the transmitter, a short pause allows the Field Communicator, AMS or a control system to initiate a request. The transmitter will receive the request, process the response message, and then continue "bursting" the data approximately three times per second.

Field Communicator v3.3

To configure the transmitter for burst mode, perform the following step:

1. From the HOME screen, enter the fast key sequence "Burst Mode."

AMS v7.0

Right click on the device and select “Configure” from the menu.

1. In the “HART” tab, use the drop down menu to select “Burst Mode ON or OFF.” For “Burst option” select the desired properties from the drop down menu. Burst options are as follows:
 - PV
 - % range/current
 - Process vars/crnt
 - Process variables
2. After selecting options click **Apply**.
3. After carefully reading the warning provided, select **yes**.

MULTIDROP COMMUNICATION

Multidropping transmitters refers to the connection of several transmitters to a single communications transmission line. Communication between the host and the transmitters takes place digitally with the analog output of the transmitters deactivated. With smart communications protocol, up to fifteen transmitters can be connected on a single twisted pair of wires, or over leased phone lines.

Multidrop installation requires consideration of the update rate necessary from each transmitter, the combination of transmitter models, and the length of the transmission line. Communication with transmitters can be accomplished with Bell 202 modems and a host implementing HART protocol. Each transmitter is identified by a unique address (1–15) and responds to the commands defined in the HART protocol. Field Communicators and AMS can test, configure, and format a multidropped transmitter the same way as a transmitter in a standard point-to-point installation.

Figure 3-10 shows a typical multidrop network. This figure is not intended as an installation diagram.

NOTE

A transmitter in multidrop mode has the analog output fixed at 4 mA. If a meter is installed to a transmitter in multidrop mode, it will alternate the display between “current fixed” and the specified meter output(s).

Figure 3-10. Typical Multidrop Network

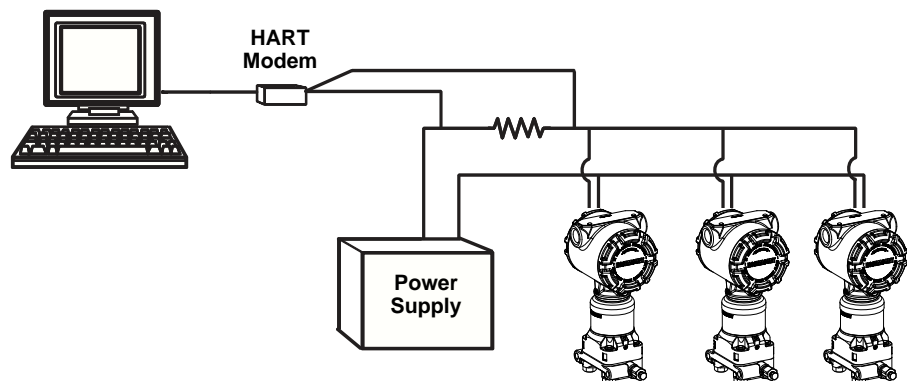

The 3051S is set to address zero (0) at the factory, which allows operation in the standard point-to-point manner with a 4–20 mA output signal. To activate multidrop communication, the transmitter address must be changed to a number from 1 to 15. This change deactivates the 4–20 mA analog output, sending it to 4 mA. It also disables the failure mode alarm signal, which is controlled by the upscale/downscale switch/jumper position. Failure signals in multidropped transmitters are communicated through HART messages.

Changing a Transmitter Address

Traditional Fast Keys	1, 4, 3, 3, 1
Device Dashboard Fast Keys	1, 2

To activate multidrop communication, the transmitter poll address must be assigned a number from 1 to 15, and each transmitter in a multidropped loop must have a unique poll address.

Field Communicator v3.3

1. From the **HOME** screen, enter the fast key sequence “Changing a Transmitter Address.”

AMS v7.0

Right click on the device and select “Configure” from the menu.

1. In the “HART” tab, in “ID” box, enter poll address located in the “Poll addr” box, click **Apply**.
2. After carefully reading the warning provided, select **yes**.

Communicating with a Multidropped Transmitter

Traditional Fast Keys	Left arrow, 3, 1, 1
Device Dashboard Fast Keys	1, 2

Field Communicator v3.3

To communicate with a multidropped transmitter, configure the Field Communicator to poll for a non-zero address.

1. From the **HOME** screen, enter the fast key sequence “Communicating with a Multidropped Transmitter.”
2. On the polling menu, scroll down and select “Digital Poll.” In this mode, the Field Communicator automatically polls for devices at addresses 0-15 upon start up.

AMS v7.0

Click on the HART modem icon and select “Scan All Devices.”

Polling a multidropped loop determines the model, address, and number of transmitters on the given loop.

Polling a Multidropped Transmitter

Traditional Fast Keys	Left arrow, 3, 1
Device Dashboard Fast Keys	1, 2

Field Communicator v3.3

1. From the **HOME** screen, enter the fast key sequence “Polling a Multidropped Transmitter.”

AMS v7.0

Click on the HART modem icon and select “Scan All Devices.”

Rosemount 3051S Series

Reference Manual
00809-0100-4801, Rev FA
October 2010

Section 4 Operation and Maintenance

Overview	page 4-1
Calibration for HART Protocol	page 4-1
Field Upgrades	page 4-15

OVERVIEW

This section contains information on commissioning and operating 3051S Pressure Transmitters. Tasks that should be performed on the bench prior to installation are explained in this section.

Instructions for performing configuration functions are given for Field Communicator version 3.3 and AMS version 7.0. For convenience, Field Communicator fast key sequences are labeled “Fast Keys” for each software function below the appropriate headings.

CALIBRATION FOR HART PROTOCOL

Calibrating a 3051S transmitter may include the following procedures:

- Rerange: Sets the 4 and 20 mA points at required pressures.
- Sensor Trim: Adjusts the position of the factory sensor characterization curve to optimize performance over a specified pressure range, or to adjust for mounting effects.
- Analog Output Trim: Adjusts the analog output to match the plant standard or the control loop.

The 3051S SuperModule uses a microprocessor that contains information about the sensor’s specific characteristics in response to pressure and temperature inputs. A smart transmitter compensates for these sensor variations. The process of generating the sensor performance profile is called factory sensor characterization. Factory sensor characterization also provides the ability to readjust the 4 and 20 mA points without applying pressure to the transmitter.

Trim and rerange functions also differ. Reranging sets analog output to the selected upper and lower range points and can be done with or without an applied pressure. Reranging does not change the factory sensor characterization curve stored in the microprocessor. Sensor trimming requires an accurate pressure input and adds additional compensation that adjusts the position of the factory sensor characterization curve to optimize performance over a specific pressure range.

NOTE

Sensor trimming adjusts the position of the factory sensor characterization curve. It is possible to degrade performance of the transmitter if the trim is done improperly or with inaccurate equipment.

Rosemount 3051S Series

Table 4-1. Recommended Calibration Tasks

Transmitter	Bench Calibration Tasks	Field Calibration Tasks
3051S_CD 3051S_CG 3051S_L 3051S_TG, Range 1-4	<ol style="list-style-type: none"> 1. Set output configuration parameters: <ol style="list-style-type: none"> a. Set the range points. b. Set the output units. c. Set the output type. d. Set the damping value. 2. <i>Optional:</i> Perform a sensor trim. (Accurate pressure source required) 3. <i>Optional:</i> Perform an analog output trim. (Accurate multimeter required) 	<ol style="list-style-type: none"> 1. Reconfigure parameters if necessary. 2. Zero trim the transmitter to compensate for mounting effects or static pressure effects.
3051S_CA 3051S_TA 3051S_TG, Range 5	<ol style="list-style-type: none"> 1. Set output configuration parameters: <ol style="list-style-type: none"> a. Set the range points. b. Set the output units. c. Set the output type. d. Set the damping value. 2. <i>Optional:</i> Perform a sensor trim if equipment available (accurate absolute pressure source required), otherwise perform the low trim value section of the sensor trim procedure. 3. <i>Optional:</i> Perform an analog output trim (Accurate multimeter required) 	<ol style="list-style-type: none"> 1. Reconfigure parameters if necessary. 2. Perform low trim value section of the sensor trim procedure to correct for mounting position effects.

NOTE:

A Field Communicator is required for all sensor and output trim procedures.

Rosemount 3051S_C Range 4 and Range 5 transmitters require a special calibration procedure when used in differential pressure applications under high static line pressure (see “Compensating for Line Pressure (Range 4 and Range 5)” on page 4-10).

Rosemount 3051S_TG Range 5 transmitters use an absolute sensor that requires an accurate absolute pressure source to perform the optional sensor trim.

Calibration Overview

Complete calibration of the 3051S pressure transmitter involves the following tasks:

Configure the analog output parameters

- Set Process Variable Units (page 3-8)
- Set Output Type (page 3-8)
- Rerange (page 3-9)
- Set Damping (page 3-11)

Calibrate the sensor

- Sensor Trim (page 4-6)
- Zero Trim (page 4-6)

Calibrate the 4–20 mA output

- 4–20 mA Output Trim (page 4-8); or
- 4–20 mA Output Trim Using Other Scale (page 4-9)

Figure 4-1 on page 4-3 illustrates 3051S transmitter data flow. Data flow can be summarized in four major steps:

1. A change in pressure is measured by a change in the sensor output (Sensor Signal).
2. The sensor signal is converted to a digital format that is understood by the microprocessor (Analog-to-Digital Signal Conversion).
3. Corrections are performed in the microprocessor to obtain a digital representation of the process input (Digital PV).
4. The Digital PV is converted to an analog value (Digital-to-Analog Signal Conversion).

Figure 4-1 also identifies the approximate transmitter location for each calibration task. Data flows from left to right, and a parameter change affects all values to the right of the changed parameter.

Not all calibration procedures should be performed for each 3051S transmitter. Some procedures are appropriate for bench calibration, but should not be performed during field calibration. Table 4-1 identifies the recommended calibration procedures for each type of 3051S transmitter for bench or field calibration.

Figure 4-1. Transmitter Data Flow with Calibration Options

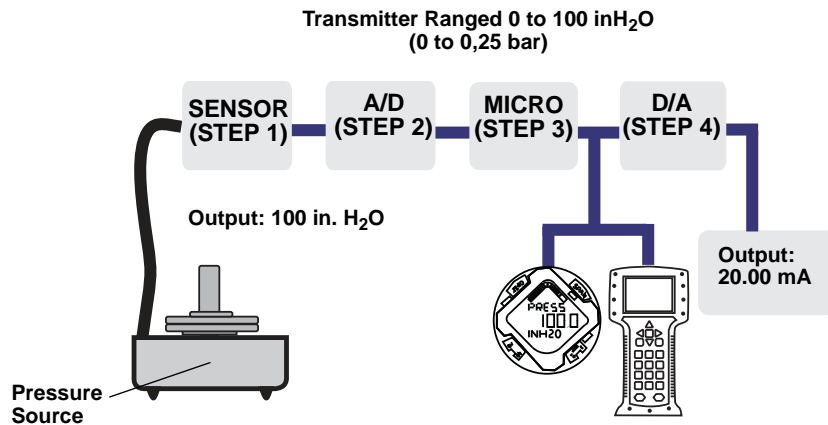

Rosemount 3051S Series

Determining Calibration Frequency

Calibration frequency can vary greatly depending on the application, performance requirements, and process conditions. Use the following procedure to determine calibration frequency that meets the needs of your application.

1. Determine the performance required for your application.
2. Determine the operating conditions.
3. Calculate the Total Probable Error (TPE).
4. Calculate the stability per month.
5. Calculate the calibration frequency.

Sample Calculation

Step 1: Determine the performance required for your application.

Required Performance: 0.30% of span

Step 2: Determine the operating conditions.

Transmitter: 3051S_CD, Range 2A [URL=250 inH₂O(623 mbar)], classic performance

Calibrated Span: 150 inH₂O (374 mbar)

Ambient Temperature Change: ± 50 °F (28 °C)

Line Pressure: 500 psig (34,5 bar)

Step 3: Calculate total probable error (TPE).

$$TPE = \sqrt{(\text{ReferenceAccuracy})^2 + (\text{TemperatureEffect})^2 + (\text{StaticPressureEffect})^2} = 0.112\% \text{ of span}$$

Where:

Reference Accuracy = ± 0.055% of span

Ambient Temperature Effect =

$$\pm \left(\frac{0.0125 \times \text{URL}}{\text{Span}} + 0.0625 \right) \text{ per } 50 \text{ }^\circ\text{F} = \pm 0.0833\% \text{ of span}$$

Span Static Pressure Effect⁽¹⁾ =

$$0.1\% \text{ reading per } 1000 \text{ psi (69 bar)} = \pm 0.05\% \text{ of span at maximum span}$$

(1) Zero static pressure effect removed by zero trimming at line pressure.

Step 4: Calculate the stability per month.

$$\text{Stability} = \pm \left[\frac{0.125 \times \text{URL}}{\text{Span}} \right] \% \text{ of span for 5 years} = \pm 0.0035\% \text{ of span per month}$$

Step 5: Calculate calibration frequency.

$$\text{Cal. Freq.} = \frac{(\text{Req. Performance} - \text{TPE})}{\text{Stability per Month}} = \frac{(0.3\% - 0.112\%)}{0.0035\%} = 54 \text{ months}$$

Choosing a Trim Procedure

To decide which trim procedure to use, you must first determine whether the analog-to-digital section or the digital-to-analog section of the transmitter electronics needs trimming. Refer to Figure 4-1 and perform the following procedure:

1. Connect a pressure source, a Field Communicator or AMS, and a digital readout device to the transmitter.
2. Establish communication between the transmitter and the Field Communicator.
3. Apply pressure equal to the upper range point pressure.
4. Compare the applied pressure to the pressure process variable value on the Process Variables menu on the Field Communicator or the Process Variables screen in AMS. For instructions on how to access process variables, see page 3-7 of Section 3: Configuration.
 - a. If the pressure reading does not match the applied pressure (with high-accuracy test equipment), perform a sensor trim. See “Sensor Trim Overview” on page 4-5 to determine which trim to perform.
5. Compare the Analog Output (AO) line, on the Field Communicator or AMS, to the digital readout device.
 - a. If the AO reading does not match the digital readout device (with high-accuracy test equipment), perform an analog output trim. See “Analog Output Trim” on page 4-7.

Sensor Trim Overview

Trim the sensor using either sensor or zero trim functions. Trim functions vary in complexity and are application-dependent. Both trim functions alter the transmitter’s interpretation of the input signal.

Zero trim is a single-point offset adjustment. It is useful for compensating for mounting position effects and is most effective when performed with the transmitter installed in its final mounting position. Since this correction maintains the slope of the characterization curve, it should not be used in place of a sensor trim over the full sensor range.

When performing a zero trim with a manifold, refer to Manifold Operation on page 2-23.

NOTE

Do not perform a zero trim on 3051S Absolute pressure transmitters. Zero trim is zero based, and absolute pressure transmitters reference absolute zero. To correct mounting position effects on a 3051S Absolute Pressure Transmitter, perform a low trim within the sensor trim function. The low trim function provides an offset correction similar to the zero trim function, but it does not require zero-based input.

Sensor trim is a two-point sensor calibration where two end-point pressures are applied, and all output is linearized between them. Always adjust the low trim value first to establish the correct offset. Adjustment of the high trim value provides a slope correction to the characterization curve based on the low trim value. The trim values allow you to optimize performance over your specified measuring range at the calibration temperature.

Rosemount 3051S Series

Zero Trim

Fast Keys	1, 2, 3, 3, 1
Device Dashboard Fast Keys	3, 4, 1, 3

NOTE

The transmitter must be within three percent of true zero (zero-based) in order to calibrate with zero trim function.

Field Communicator

Calibrate the sensor with a Field Communicator using the zero trim function as follows:

1. Vent the transmitter and attach a Field Communicator to the measurement loop.
2. From the **HOME** screen, follow the fast key sequence “Zero Trim.”
3. Follow the commands provided by the Field Communicator to complete the zero trim adjustment.

AMS

Right click on the device and select “Calibrate,” then “Zero trim” from the menu.

1. Click **Next** after setting the control loop to manual.
2. Click **Next** to acknowledge warning.
3. Click **Next** after applying appropriate pressure to sensor.
4. Select **Next** to acknowledge the loop can be returned to automatic control.
5. Select **Finish** to acknowledge the method is complete.

Sensor Trim

Fast Keys	1, 2, 3, 3
Device Dashboard Fast Keys	3, 4, 1

NOTE

Use a pressure input source that is at least four times more accurate than the transmitter, and allow the input pressure to stabilize for ten seconds before entering any values.

Field Communicator

To calibrate the sensor with a Field Communicator using the sensor trim function, perform the following procedure:

1. Assemble and power the entire calibration system including a transmitter, Field Communicator, power supply, pressure input source, and readout device.
2. From the **HOME** screen, enter the fast key sequence under “Sensor Trim.”
3. Select 2: Lower sensor trim. The lower sensor trim value should be the sensor trim point that is closest to zero.

NOTE

Select pressure input values so that lower and upper values are equal to or outside the 4 and 20 mA points. Do not attempt to obtain reverse output by reversing the high and low points. This can be done by going to “Rerange” on page 3-9 of Section 3: Configuration. The transmitter allows approximately five percent deviation.

4. Follow the commands provided by the Field Communicator to complete the adjustment of the lower value.
5. Repeat the procedure for the upper value, replacing 2: Lower sensor trim with 3: Upper sensor trim in Step 3.

AMS

Right click on the device and select “Calibrate,” then “Sensor trim” from the menu.

1. Select “Lower sensor trim.” The lower sensor trim value should be the sensor trim point that is closest to zero.
2. Click **Next** after setting the control loop to manual.
3. Click **Next** after applying appropriate pressure to sensor.
4. Select **Next** to acknowledge the loop can be returned to automatic control.
5. Select **Finish** to acknowledge the method is complete.
6. Right click on the device and select “Calibrate,” select “Sensor trim” from the menu.
7. Select “Upper sensor trim” and repeat steps 2-5.

**Recall Factory Trim—
 Sensor Trim**

Fast Keys	1, 2, 3, 4, 1
Device Dashboard Fast Keys	3, 4, 3

The Recall Factory Trim—Sensor Trim command allows the restoration of the as-shipped factory settings of the sensor trim. This command can be useful for recovering from an inadvertent zero trim of an absolute pressure unit or inaccurate pressure source.

Field Communicator

Enter the fast key sequence “Recall Factory Trim—Sensor Trim.”

AMS

Right click on the device and select “Calibrate,” then “Recall Factory Trim” from the menu.

1. Click **Next** after setting the control loop to manual.
2. Select “Sensor trim” under “Trim to recall” and click **Next**.
3. Click **Next** to acknowledge restoration of trim values is complete.
4. Select **Next** to acknowledge the loop can be returned to automatic control.
5. Select **Finish** to acknowledge the method is complete.

Analog Output Trim

The Analog Output Trim commands allow you to adjust the transmitter’s current output at the 4 and 20 mA points to match the plant standards. This command adjusts the digital to analog signal conversion (see Figure 4-1 on page 4-3).

Rosemount 3051S Series

Digital-to-Analog Trim

Fast Keys	1, 2, 3, 2, 1
Device Dashboard Fast Keys	3, 4, 2

Field Communicator

To perform a digital-to-analog trim with a Field Communicator, perform the following procedure.

1. From the **HOME** screen, enter the fast key sequence “Digital-to-Analog Trim.” Select **OK** after setting the control loop to manual, see “Setting the Loop to Manual” on page 3-2.
2. Connect an accurate reference milliamp meter to the transmitter at the **CONNECT REFERENCE METER** prompt. Connect the positive lead to the positive terminal and the negative lead to the test terminal in the transmitter terminal compartment, or shunt power through the reference meter at some point.
3. Select **OK** after connecting the reference meter.
4. Select **OK** at the **SETTING FLD DEV OUTPUT TO 4 MA** prompt. The transmitter outputs 4.0 mA.
5. Record the actual value from the reference meter, and enter it at the **ENTER METER VALUE** prompt. The Field Communicator prompts you to verify whether or not the output value equals the value on the reference meter.
6. Select 1: Yes, if the reference meter value equals the transmitter output value, or 2: No if it does not.
 - a. If 1 is selected: Yes, proceed to Step 7.
 - b. If 2 is selected: No, repeat Step 5.
7. Select **OK** at the **SETTING FLD DEV OUTPUT TO 20 MA** prompt, and repeat Steps 5 and 6 until the reference meter value equals the transmitter output value.
8. Select **OK** after the control loop is returned to automatic control.

AMS

Right click on the device and select “Calibrate,” then “D/A Trim” from the menu.

1. Click **Next** after setting the control loop to manual.
2. Click **Next** after connecting the reference meter.
3. Click **Next** at the “Setting fld dev output to 4mA” screen.
4. Record the actual value from the reference meter, and enter it at the “Enter meter value” screen and click **Next**.
5. Select **Yes**, if the reference meter value equals the transmitter output value, or **No** if it does not. Click **Next**.
 - a. If Yes is selected, proceed to Step 6.
 - b. If No is selected, repeat Step 4.
6. Click **Next** at the “Setting fld dev output to 20mA” screen.
7. Repeat Step 4 - Step 5 until the reference meter equals the transmitter output value.
8. Select **Next** to acknowledge the loop can be returned to automatic control.
9. Select **Finish** to acknowledge the method is complete.

Digital-to-Analog Trim Using Other Scale

Fast Keys	1, 2, 3, 2, 2
Device Dashboard Fast Keys	3, 4, 2, 2

The Scaled D/A Trim command matches the 4 and 20 mA points to a user selectable reference scale other than 4 and 20 mA (for example, 1 to 5 volts if measuring across a 250 ohm load, or 0 to 100 percent if measuring from a Distributed Control System (DCS)). To perform a scaled D/A trim, connect an accurate reference meter to the transmitter and trim the output signal to scale, as outlined in the Output Trim procedure.

NOTE

Use a precision resistor for optimum accuracy. If you add a resistor to the loop, ensure that the power supply is sufficient to power the transmitter to a 23 mA output (maximum alarm value) with additional loop resistance.

Field Communicator

Enter the fast key sequence “Digital-to-Analog Trim Using Other Scale.”

AMS

Right click on the device and select “Calibrate,” then “Scaled D/A trim” from the menu.

1. Click **Next** after setting the control loop to manual.
2. Select **Change** to change scale, click **Next**.
3. Enter Set scale-Lo output value, click **Next**.
4. Enter Set scale-Hi output value, click **Next**.
5. Click **Next** to proceed with Trim.
6. Click **Next** after connecting the reference meter.
7. Click **Next** at the “Setting fld dev output to 4 mA” screen.
8. Record the actual value from the reference meter, and enter it at the “Enter meter value” screen and click **Next**.
9. Select **Yes**, if the reference meter value equals the transmitter output value, or **No** if it does not. Click **Next**.
 - a. If Yes is selected, proceed to Step 10.
 - b. If No is selected, repeat Step 8.
10. Click **Next** at the “Setting fld dev output to 20mA” screen.
11. Repeat Step 8 - Step 9 until the reference meter equals the transmitter output value.
12. Select **Next** to acknowledge the loop can be returned to automatic control.
13. Select **Finish** to acknowledge the method is complete.

The following specifications show the static pressure effect for the 3051S Range 4 and Range 5 transmitters used in differential pressure applications:

Zero Effect:

± 0.1% of the upper range limit per 1000 psi (69 bar) for line pressures from 0 to 2000 psi (0 to 138 bar)

For line pressures above 2000 psi (138 bar), the zero effect error is ± 0.2% of the upper range limit plus an additional ± 0.2% of upper range limit error for each 1000 psi (69 bar) of line pressure above 2000 psi (138 bar).

Example: Line pressure is 3000 psi (207 bar). Zero effect error calculation:

$$\pm \{0.2 + 0.2 \times [3 \text{ kpsi} - 2 \text{ kpsi}]\} = \pm 0.4\% \text{ of the upper range limit}$$

Span Effect:

Correctable to ±0.2% of reading per 1000 psi (69 bar) for line pressures from 0 to 3626 psi (0 to 250 bar)

The systematic span shift caused by the application of static line pressure is -1.00% of reading per 1000 psi (69 bar) for Range 4 transmitters, and -1.25% of reading per 1000 psi (69 bar) for Range 5 transmitters.

Use the following example to compute corrected input values.

Example

A transmitter with model number 3051S_CD4 will be used in a differential pressure application where the static line pressure is 1200 psi (83 bar). The transmitter output is ranged with 4 mA at 500 inH₂O (1,2 bar) and 20 mA at 1500 inH₂O (3,7 bar).

To correct for systematic error caused by high static line pressure, first use the following formulas to determine corrected values for the low trim and high trim.

$$LT = LRV + S \times (LRV) \times P$$

Where: LT = Corrected Low Trim Value
 LRV = Lower Range Value
 S = -(Span shift per specification)
 P = Static Line Pressure

$$HT = URV + S \times (URV) \times P$$

Where: HT = Corrected High Trim Value
 URV = Upper Range Value
 S = -(Span shift per specification)
 P = Static Line Pressure

In this example:

URV =	1500 inH ₂ O (3.74 bar)
LRV =	500 inH ₂ O (1.25 bar)
P =	1200 psi (82.74 bar)
S =	± 0.01/1000

To calculate the low trim (LT) value:

LT =	$500 + (0.01/1000)(500)(1200)$
LT =	506 inH ₂ O (1.26 bar)

To calculate the high trim (HT) value:

HT =	$1500 + (0.01/1000)(1500)(1200)$
HT =	1518 inH ₂ O (3.78 bar)

Complete a 3051S sensor trim and enter the corrected values for low trim (LT) and high trim (HT), refer to “Sensor Trim” on page 4-6.

Enter the corrected input values for low trim and high trim through the Field Communicator keypad after you apply the value of pressure as the transmitter input.

NOTE

After sensor trimming 3051S Range 4 and 5 transmitters for high differential pressure applications, verify that the 4 and 20 mA points are at values using the Field Communicator. For the example above, this would be 500 and 1500 respectively. The zero effect can be eliminated by doing a zero sensor trim at line pressure after installation without affecting the completed calibration.

Diagnostic Messages

In addition to output, the LCD displays abbreviated operation, error, and warning messages for troubleshooting. Messages appear according to their priority; normal operating messages appear last. To determine the cause of a message, use a Field Communicator or AMS to further interrogate the transmitter. A description of each LCD diagnostic message follows.

Error Indicator

An error indicator message appears on the LCD display to warn of serious problems affecting the operation of the transmitter. The meter displays an error message until the error condition is corrected, "ERROR" appears at the bottom of the display, and analog output is driven to the specified alarm level. No other transmitter information is displayed during an alarm condition.

FAIL MODULE

The SuperModule is malfunctioning. Possible sources of problems include:

Pressure or temperature updates are not being received in the SuperModule.

A non-volatile memory fault that will affect transmitter operation has been detected in the module by the memory verification routine.

Some non-volatile memory faults are user-repairable. Use a Field Communicator or AMS to diagnose the error and determine if it is repairable. Any error message that ends in "Factory" is not repairable. In cases of non-user-repairable errors, replace the SuperModule. See "Disassembly Procedures" on page 5-3.

FAIL CONFIG

A memory fault has been detected in a location that could effect transmitter operation, and is user-accessible. To correct this problem, use a Field Communicator or AMS to interrogate and reconfigure the appropriate portion of the transmitter memory.

Warnings

Warnings appear on the LCD display to alert you of user-repairable problems with the transmitter, or current transmitter operations. Warnings appear alternately with other transmitter information until the warning condition is corrected or the transmitter completes the operation that warrants the warning message.

LCD UPDATE ERROR

A communications error has occurred between the LCD and the SuperModule. Verify the LCD is firmly seated by squeezing the two tabs, pulling the LCD out, and snapping it back into place. Replace LCD.

PV LIMIT

The primary variable read by the transmitter is outside of the transmitter's range.

NONPV LIMIT

A non-primary variable read by the transmitter is outside of the transmitter's range.

CURR SAT

The primary variable read by the module is outside of the specified range, and the analog output has been driven to saturation levels.

XMRT INFO

A non-volatile memory fault has been detected in the transmitter memory by the memory verification routine. The memory fault is in a location containing transmitter information. To correct this problem, use a Field Communicator or AMS to interrogate and reconfigure the appropriate portion of the transmitter memory. This warning does not affect the transmitter operation.

PRESS ALERT

A HART alert when the pressure variable read by the transmitter is outside of the user set alert limits.

TEMP ALERT

A HART alert when the sensor temperature variable read by the transmitter is outside of the user set alert limits.

Operation

Normal operation messages appear on the LCD display to confirm actions or inform you of transmitter status. Operation messages are displayed with other transmitter information, and warrant no action to correct or alter the transmitter settings.

LOOP TEST

A loop test is in progress. During a loop test or 4–20 mA trim, the analog output is set to a fixed value. The meter display alternates between the current selected in milliamps and “LOOP TEST.”

ZERO PASS

The zero value, set with the local zero adjustment button, has been accepted by the transmitter, and the output should change to 4 mA.

ZERO FAIL

The zero value, set with the local zero adjustment button, exceeds the maximum rangedown allowed for a particular range, or the pressure sensed by the transmitter exceeds the sensor limits.

SPAN PASS

The span value, set with the local span adjustment button, has been accepted by the transmitter, and the output should change to 20 mA.

SPAN FAIL

The span value, set with the local span adjustment button, exceeds the maximum rangedown allowed for a particular range, or the pressure sensed by the transmitter exceeds the sensor limits.

KEYS DISABL

This message appears during reranging with the integral zero and span buttons and indicates that the transmitter local zero and span adjustments have been disabled. The adjustments have been disabled by software commands from the Field Communicator or AMS. Keys are disabled when write protect jumper is “ON.” If alarm and security adjustments are not installed, the transmitter will operate normally with the default alarm condition alarm high and the security off.

STUCK KEY

The zero or span button is stuck in the depressed state or pushed too long.

FIELD UPGRADES

Labeling

 Each housing and each SuperModule is labeled individually, so it is imperative that the approval codes on each label match exactly during upgrade. The label on the SuperModule reflects the replacement model code for reordering an assembled unit. The housing labeling will only reflect the approvals and communication protocol of the housing.

Upgrading Electronics

The PlantWeb housing allows for electronics upgrades. Different electronics assemblies provide new functionality and are easily interchanged for upgrade. Keyed slots guide the assemblies into place, and assemblies are secured with two provided screws. If the transmitter you are intending to upgrade does not have a PlantWeb housing, refer to the spare parts section on page A-38 for ordering information.

Hardware Adjustments

The D1 option is available for local hardware adjustments. This option is available for both the PlantWeb and Junction Box housings. In order to use zero, span, alarm and security functions, replace the existing PlantWeb assembly with the Hardware Adjustment Interface Assembly (p/n 03151-9017-0001). Install the LCD display or hardware adjustment module to activate the hardware adjustments.

Advanced HART Diagnostics

The DA2 option is available for Advanced HART Diagnostics. This option requires the use of the PlantWeb housing. In order to gain full access to the Advanced HART Diagnostic capabilities, simply add the 3051S HART Diagnostics Electronics assembly (p/n 03151-9071-0001). Before replacing the existing assembly with the new 3051S Diagnostics Electronics assembly, record the transmitter configuration. Transmitter configuration data must be reentered after adding the Advanced HART Diagnostics electronics assembly and before putting the transmitter back into operation.

FOUNDATION Fieldbus

FOUNDATION fieldbus Upgrade Kits are available for PlantWeb housings. Each kit includes an electronics assembly and terminal block. To upgrade to FOUNDATION fieldbus, replace the existing electronics assembly with the FOUNDATION fieldbus Output Electronics assembly (P/N 03151-9020-0001) and replace the existing terminal block with the FOUNDATION Fieldbus terminal block (part number will vary based on the kit selected). Table 4-2 shows the available kits.

Table 4-2. FOUNDATION fieldbus Upgrade Kits

Kit	Part Number
Standard FOUNDATION fieldbus Upgrade Kit	03151-9021-0021
Transient Protection FOUNDATION fieldbus Upgrade Kit	03151-9021-0022
FISCO FOUNDATION fieldbus Upgrade Kit	03151-9021-0023

Refer to “Disassembly Procedures” on page 5-3 for information on assembly.

Section 5 Troubleshooting

Overview	page 5-1
Safety Messages	page 5-1
Disassembly Procedures	page 5-3
Reassembly Procedures	page 5-5

OVERVIEW

Table 5-1 provides summarized maintenance and troubleshooting suggestions for the most common operating problems.

If you suspect malfunction despite the absence of any diagnostic messages on the Field Communicator display, follow the procedures described here to verify that transmitter hardware and process connections are in good working order. Always deal with the most likely checkpoints first.

SAFETY MESSAGES

Procedures and instructions in this section may require special precautions to ensure the safety of the personnel performing the operations. Information that raises potential safety issues is indicated by a warning symbol (⚠). Refer to the following safety messages before performing an operation preceded by this symbol.

Warnings (⚠)

⚠ WARNING
<p>Explosions can result in death or serious injury.</p> <ul style="list-style-type: none">• Do not remove the transmitter covers in explosive environments when the circuit is live.• Transmitter covers must be fully engaged to meet explosion proof requirements.• Before connecting a communicator in an explosive atmosphere, make sure that the instruments in the loop are installed according to intrinsically safe or nonincendive field wiring practices.
<p>Improper installation or repair of the SuperModule with high pressure option (P0) could result in death or serious injury.</p> <ul style="list-style-type: none">• For safe assembly, the high pressure SuperModule must be installed with ASTM A193 Class 2 Grade B8M Bolts and either a 305 manifold or a DIN-compliant traditional flange.
<p>Static electricity can damage sensitive components.</p> <ul style="list-style-type: none">• Observe safe handling precautions for static-sensitive components.

Rosemount 3051S Series

Table 5-1. Rosemount 3051S troubleshooting table

Symptom	Corrective Actions
Transmitter milliamp reading is zero	Verify power is applied to signal terminals
	Check power wires for reversed polarity
	Verify terminal voltage is 10.5 to 42.4 Vdc
	Check for open diode across test terminal
Transmitter Not Communicating with Field Communicator	Verify the output is between 4 and 20 mA or saturation levels
	Verify clean DC Power to transmitter (Max AC noise 0.2 volts peak to peak)
	Check loop resistance, 250 Ω minimum (PS voltage -transmitter voltage/loop current)
	Check if unit is addressed properly
Transmitter milliamp reading is low or high	Verify applied pressure
	Verify 4 and 20 mA range points
	Verify output is not in alarm condition
	Verify if 4 – 20 mA output trim is required
Transmitter will not respond to changes in applied pressure	Check test equipment
	Check impulse piping or manifold for blockage
	Verify applied pressure is between the 4 and 20 mA set points
	Verify output is not in alarm condition
Digital Pressure Variable reading is low or high	Verify transmitter is not in Loop Test mode
	Check test equipment (verify accuracy)
	Check impulse piping for blockage or low fill in wet leg
	Verify transmitter is calibrated properly
Digital Pressure Variable reading is erratic	Verify pressure calculations for application
	Check application for faulty equipment in pressure line
	Verify transmitter is not reacting directly to equipment turning on/off
Milliamp reading is erratic	Verify damping is set properly for application
	Verify power source to transmitter has adequate voltage and current
	Check for external electrical interference
	Verify transmitter is properly grounded
Transmitter output is normal but LCD is off Diagnostics indicates an LCD problem	Verify shield for twisted pair is only grounded at one end
	Replace LCD

DISASSEMBLY PROCEDURES

 Do not remove the instrument cover in explosive atmospheres when the circuit is live.

Remove from Service

Be aware of the following:

- Follow all plant safety rules and procedures.
- Isolate and vent the process from the transmitter before removing the transmitter from service.
- Remove all electrical leads and conduit.
- Detach the process flange by removing the four flange bolts and two alignment screws that secure it.
- Do not scratch, puncture, or depress the isolating diaphragms.
- Clean isolating diaphragms with a soft rag and a mild cleaning solution, and rinse with clear water.
- Whenever you remove the process flange or flange adapters, visually inspect the PTFE O-rings. Replace the O-rings if they show any signs of damage, such as nicks or cuts. If they are not damaged, reuse them.

The 3051S transmitter is attached to the process connection by four bolts and two cap screws. Remove the bolts and separate the transmitter from the process connection. Leave the process connection in place and ready for re-installation.

The 3051S in-line transmitter is attached to the process by a single hex nut process connection. Loosen the hex nut to separate the transmitter from the process.

Remove Terminal Block

Electrical connections are located on the terminal block in the compartment labelled "FIELD TERMINALS."

PlantWeb Housing

Loosen the two small screws located at the 10 o'clock and 4 o'clock positions, and pull the entire terminal block out.

Junction Box Housing

Loosen the two small screws located at the 8 o'clock and 4 o'clock positions, and pull the entire terminal block out. This procedure will expose the SuperModule connector, see Figure 5-1.

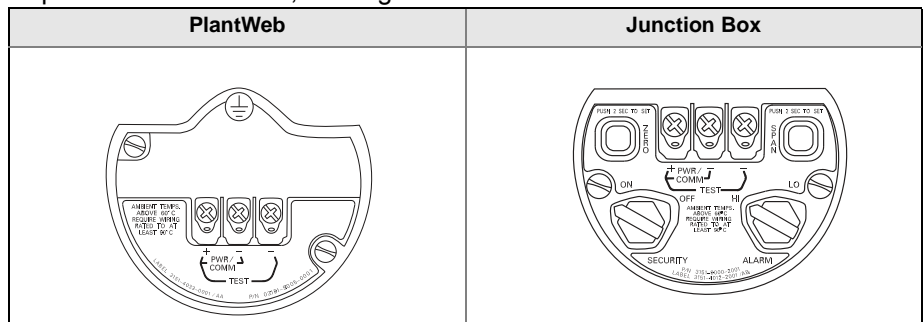

Rosemount 3051S Series

Remove Interface Assembly

The Standard Interface Assembly, Adjustment Interface Assembly, Safety Certified Electronics Assembly (with yellow casing), or HART Diagnostics Electronics Assembly (black casing with white label) is located in the compartment opposite the terminal side in the PlantWeb housing. To remove the assembly, perform the following procedure.

1. Remove the housing cover opposite the field terminal side.
2. Remove the LCD Display or Adjustment Module, if applicable. To do this, hold in the two clips and pull outward. This will provide better access to the two screws located on the Standard Interface Assembly, Adjustment Interface Assembly, Safety Certified Electronics Assembly, or HART Diagnostics Electronics Assembly.
3. Loosen the two small screws located on the assembly in the 8 o'clock and 2 o'clock positions.
4. Pull out the assembly to expose and locate the SuperModule connector, see Figure 5-1.
5. Grasp the SuperModule connector and pull upwards (avoid pulling wires). Housing rotation may be required to access locking tabs. (PlantWeb housing only)

Figure 5-1. SuperModule connector view

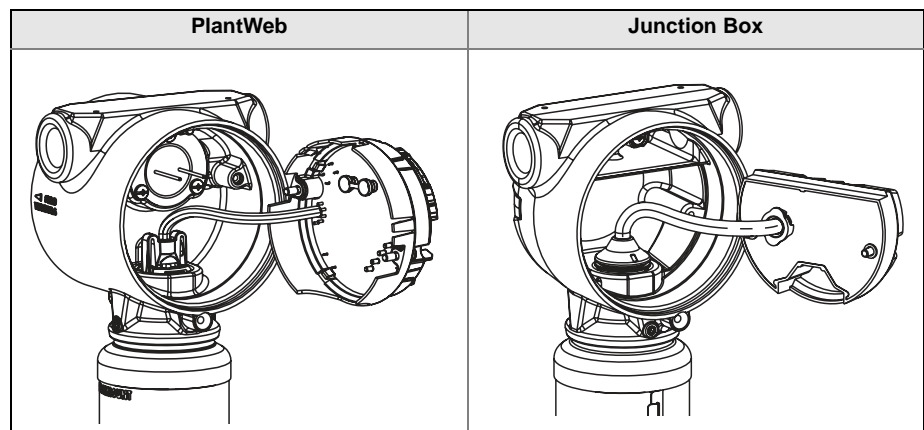

Remove the SuperModule from the Housing

IMPORTANT

To prevent damage to the SuperModule cable, disconnect it from the PlantWeb assembly or Junction Box terminal block before you remove the SuperModule from the housing.

1. Loosen the housing rotation set screw with a $\frac{3}{32}$ -inch hex wrench, then rotate back one full turn.
2. Unscrew the housing from the SuperModule.

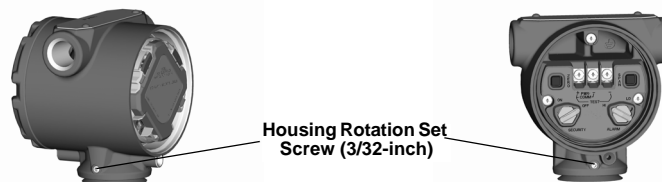

REASSEMBLY PROCEDURES

IMPORTANT

The V-Seal must be installed at the bottom of the housing.

Attach SuperModule to PlantWeb or Junction Box Housing

1. Apply a light coat of low temperature silicon grease to the SuperModule threads and O-ring.
-  2. Thread the housing completely onto the SuperModule. The housing must be no more than one full turn from flush with the SuperModule to comply with explosion-proof requirements.
3. Tighten the housing rotation set screw using a $\frac{3}{32}$ -inch hex wrench.

Install Interface Assembly in the PlantWeb Housing

1. Apply a light coat of low temperature silicon grease to the SuperModule connector.
2. Insert the SuperModule connector into the top of the SuperModule.
3. Gently slide the assembly into the housing, making sure the pins from the PlantWeb housing properly engage the receptacles on the assembly.
4. Tighten the captive mounting screws.
-  5. Attach the PlantWeb housing cover and tighten so that metal contacts metal to meet explosion-proof requirements.

Install the Terminal Block

PlantWeb Housing

1. Gently slide the terminal block into the housing, making sure the pins from the PlantWeb housing properly engage the receptacles on the terminal block.
2. Tighten the captive screws on the terminal block.
-  3. Attach the PlantWeb housing cover and tighten so that metal contacts metal to meet explosion-proof requirements.

Junction Box Housing

1. Apply a light coat of low temperature silicon grease to the SuperModule connector.
2. Insert the SuperModule connector into the top of the SuperModule.
3. Push the terminal block into the housing and hold for screw position alignment.
4. Tighten the captive mounting screws.
-  5. Attach the Junction Box housing cover and tighten so that metal contacts metal to meet explosion-proof requirements.

NOTE

If the installation uses a manifold, see “Rosemount 305, 306 and 304 Manifolds” on page 2-21.

Rosemount 3051S Series

Reassemble the Process Flange



1. Inspect the SuperModule PTFE O-rings. If the O-rings are undamaged, reusing them is recommended. If the O-rings are damaged (if they have nicks or cuts, for example), replace them with new O-rings.

NOTE

If replacing the O-rings, be careful not to scratch or deface the O-ring grooves or the surface of the isolating diaphragm when removing the damaged O-rings.

2. Install the process flange on the SuperModule. To hold the process flange in place, install the two alignment screws to finger tight (screws are not pressure retaining). Do not overtighten; this will affect module-to-flange alignment.
3. Install the appropriate flange bolts.
 - a. If the installation requires a 1/4–18 NPT connection(s), use four 1.75-in. flange bolts. Go to **step d**.
 - b. If the installation requires a 1/2–14 NPT connection(s), use four 2.88-in. process flange/adaptor bolts. For gage pressure configurations, use two 2.88-in. bolts and two 1.75-in. bolts. Go to **step c**.
 - c. Hold the flange adapters and adapter O-rings in place while finger-tightening the bolts. Go to **step e**.
 - d. Finger tighten the bolts.
 - e. Tighten the bolts to the initial torque value using a crossed pattern. See Table 5-2 on page 5-7 for appropriate torque values.
 - f. Tighten the bolts to the final torque value using a crossed pattern. See Table 5-2 for appropriate torque values. When fully tightened, the bolts should extend through the top of the module housing.
 - g. If the installation uses a conventional manifold, then install flange adapters on the process end of the manifold using the 1.75-in. flange bolts supplied with the transmitter.

Table 5-2. Bolt Installation
Torque Values

Bolt Material	Initial Torque Value	Final Torque Value
CS-ASTM-A445 Standard	300 in-lb. (34 N-m)	650 in-lb. (73 N-m)
316 SST—Option L4	150 in-lb. (17 N-m)	300 in-lb. (34 N-m)
ASTM-A-193-B7M—Option L5	300 in-lb. (34 N-m)	650 in-lb. (73 N-m)
Alloy K-500 —Option L6	300 in-lb. (34 N-m)	650 in-lb. (73 N-m)
ASTM-A-453-660—Option L7	150 in-lb. (17 N-m)	300 in-lb. (34 N-m)
ASTM-A-193-B8M—Option L8	150 in-lb. (17 N-m)	300 in-lb. (34 N-m)

4. If you replaced the PTFE SuperModule O-rings, re-torque the flange bolts after installation to compensate for cold flow.
5. Install the drain/vent valve.
 - a. Apply sealing tape to the threads on the seat. Starting at the base of the valve with the threaded end pointing toward the installer, apply two clockwise turns of sealing tape.
 - b. Take care to place the opening on the valve so that process fluid will drain toward the ground and away from human contact when the valve is opened.
 - c. Tighten the drain/vent valve to 250 in-lb. (28.25 N-m).

NOTE

After replacing O-rings on Range 1 transmitters and re-installing the process flange, expose the transmitter to a temperature of 185 °F (85 °C) for two hours. Then re-tighten the flange bolts in a cross pattern, and again expose the transmitter to a temperature of 185 °F (85 °C) for two hours before calibration.

Rosemount 3051S Series

Reference Manual
00809-0100-4801, Rev FA
October 2010

Section 6 Safety Instrumented Systems

Safety Messages	page 6-1
Certification	page 6-2
3051S Safety Certified Identification	page 6-2
Installation	page 6-2
Commissioning	page 6-3
Operation and Maintenance	page 6-5
Specifications	page 6-6
Spare Parts	page 6-6

SAFETY MESSAGES

Procedures and instructions in this section may require special precautions to ensure the safety of the personnel performing the operations. Information that raises potential safety issues is indicated by a warning symbol (⚠). Refer to the following safety messages before performing an operation preceded by this symbol.

Warnings

⚠ WARNING
<p>Explosions can result in death or serious injury.</p> <ul style="list-style-type: none">• Do not remove the transmitter covers in explosive environments when the circuit is live.• Transmitter covers must be fully engaged to meet explosion-proof requirements.• Before connecting a communicator in an explosive atmosphere, make sure the instruments in the loop are installed in accordance with intrinsically safe or nonincendive field wiring practices.
⚠ WARNING
<p>Electrical shock can result in death or serious injury.</p> <ul style="list-style-type: none">• Avoid contact with the leads and terminals. High voltage that may be present on leads can cause electrical shock.

Rosemount 3051S Series

CERTIFICATION

The 3051S safety certified pressure transmitter is certified to:
Low Demand; Type B
SIL 2 Capability for hardware (single use transmitter)
SIL 3 Capability for software (multiple use transmitter)

3051S SAFETY CERTIFIED IDENTIFICATION

All 3051S transmitters must be identified as safety certified before installing into SIS systems.

NOTE

There are two versions of safety certified 3051S pressure transmitters. For transmitters with a yellow SIS circuit board installed, please refer to Manual Supplement 00809-0700-4801.

To identify a safety certified 3051S:

1. Connect a HART host to the transmitter.
2. Check the software to verify that the software revision is 7 or higher.

Fast Key Sequence - 1, 5

Revision #'s	
Fld Dev Rev	7
Software Rev	7
Hardware Rev	16

3. Verify that option code QT is included in the transmitter model code.

INSTALLATION

No special installation is required in addition to the standard installation practices outlined in this document. Always ensure a proper seal by installing the electronics housing cover(s) so that metal contacts metal if housing is used.

Environmental limits are available in the 3051S Product Data Sheet (document number 00813-0100-4801). This document can be found at <http://www2.emersonprocess.com/siteadmincenter/PM%20Rosemount%20Documents/00813-0100-4801.pdf>

The loop should be designed so the terminal voltage does not drop below 10.5 Vdc when the transmitter output is 23.0 mA.

If hardware security switches are installed, the security switch should be in the "ON" position during normal operation. See Figure 6-2, "Security and alarm configuration (option D1)" on page 6-4. If hardware security switches are not installed, security should be "ON" in the software to prevent accidental or deliberate change of configuration data during normal operation.

COMMISSIONING

To commission the 3051S Safety Certified Transmitter, use the HART “Menu Tree” on page 3-5 and “Fast Key Sequence” on page 3-6.

NOTE

Transmitter output is not safety-rated during the following: configuration changes, multidrop, and loop test. Alternative means should be used to ensure process safety during transmitter configuration and maintenance activities.

For more information on the 375 Field Communicator see document 00809-0100-4276. AMS help can be found in the AMS on-line guides within the AMS system.

Damping

User-selected damping will affect the transmitters ability to respond to changes in the applied process. The *damping value + response time* should not exceed the loop requirements.

Fast Key Sequence - 1, 3, 6

Alarm and Saturation Levels

DCS or safety logic solver should be configured to match transmitter configuration. Figure 6-1 identifies the three alarm levels available and their operation values.

Figure 6-1. Alarm Levels

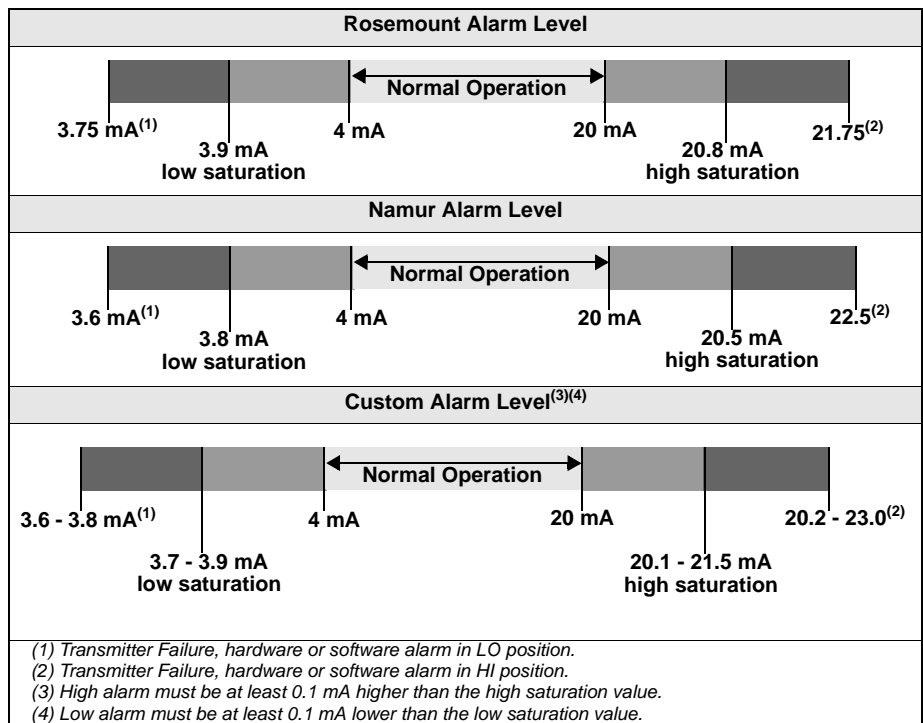

Setting the alarm values and direction varies whether the hardware switch option is installed. You can use a HART master or communicator to set the Alarm and Saturation values.

Rosemount 3051S Series

Switches installed

1. If using a communicator, use the following fast key sequence to set the Alarm and Saturation values.
Alarm Levels - Fast Key; 1, 4, 2, 7, 7
Saturation Levels - Fast Key; 1, 4, 2, 7, 8
2. Manually set the direction for the Alarm to HI or LO using the ALARM switch as shown in Figure 6-2.

Switches not installed

3. If using a communicator, use the following fast key sequence to set the Alarm and Saturation values and the Alarm Direction:
Alarm Levels - Fast Key; 1, 4, 2, 7, 7
Saturation Levels - Fast Key; 1, 4, 2, 7, 8
Alarm Direction Fast Key; 1, 4, 2, 7, 6

Figure 6-2. Security and alarm configuration (option D1)

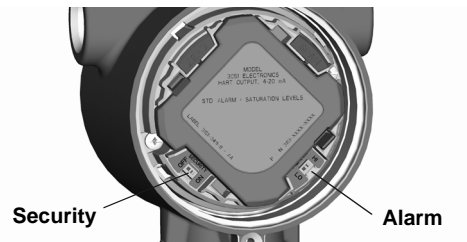

OPERATION AND MAINTENANCE

Proof Test

The following proof tests are recommended.

Proof test results and corrective actions taken must be documented at http://rosemount.d1asia.ph/rosemount/safety/ReportAFailure_newweb.asp (*Report a Failure button*) in the event that an error is found in the safety functionality.

Use “Fast Key Sequence” on page 3-6 to perform a Loop Test, Analog Output Trim, or Sensor Trim.

Proof Test 1

Conducting an analog output Loop Test satisfies the proof test requirements and will detect more than 52% of DU failures not detected by the 3051S_C or 3051S_L automatic diagnostics, and more than 62% of DU failures not detected by the 3051S_T automatic diagnostics.

Required tools: HART host/communicator and mA meter.

1. On HART host/communicator enter the Fast Key Sequence 1, 2, 2.
2. Select “4 Other.”
3. Enter the milliampere value representing a high alarm state.
4. Check the reference meter to verify the mA output corresponds to the entered value.
5. Enter the milliampere value representing a low alarm state.
6. Check the reference meter to verify the mA output corresponds to the entered value.
7. Document the test results per your requirements.

Proof Test 2

This proof test, when combined with the Proof Test 1, will detect over 92% of DU failures not detected by the 3051S_C or 3051S_L automatic diagnostics, and over 95% of DU failures not detected by the 3051S_T automatic diagnostics.

Required tools: HART host/communicator and pressure calibration equipment.

1. Perform a minimum two point sensor calibration check using the 4-20mA range points as the calibration points.
2. Check the reference mA meter to verify the mA output corresponds to the pressure input value.
3. If necessary, use one of the “Trim” procedures on page 4-5.
4. Document the test results per your requirements.

NOTE

The user determines the proof test requirements for impulse piping.

Rosemount 3051S Series

Inspection

Visual Inspection

Not required

Special Tools

Not required

Product Repair

The 3051S is repairable by major component replacement.

All failures detected by the transmitter diagnostics or by the proof-test must be reported. Feedback can be submitted electronically at http://rosemount.d1asia.ph/rosemount/safety/ReportAFailure_newweb.asp.

SPECIFICATIONS

The 3051S must be operated in accordance to the functional and performance specifications provided in the 3051S Product Data Sheet (document number 00813-0100-4801).

Failure Rate Data

The FMEDA report includes failure rates and common cause Beta factor estimates.

The report is available at

<http://www2.emersonprocess.com/en-US/brands/rosemount/Safety-Products/Pages/index.aspx>.

Product Life

50 years – based on worst case component wear-out mechanisms – not based on wear-out of process wetted materials

Report any safety related product information at

http://rosemount.d1asia.ph/rosemount/safety/ReportAFailure_newweb.asp.

SPARE PARTS

Additional spare parts are available in Appendix A: Specifications and Reference Data.

Section 7 **Advanced HART Diagnostic Suite**

Overview	page 7-1
User Interface	page 7-3
Statistical Process Monitoring	page 7-4
Power Advisory	page 7-20
Diagnostic Log	page 7-24
Variable Logging	page 7-26
Process Alerts	page 7-29
Service Alerts	page 7-31
Device Diagnostics	page 7-32
Smart Wireless THUM Adapter Configuration	page 7-33
Rosemount 333 Hart Tri-Loop Configuration	page 7-34
Safety Instrumented Systems (SIS) Certification	page 7-36
Other Information	page 7-40
Field Communicator Menu Trees	page 7-41

OVERVIEW

The Advanced HART Diagnostic Suite is an extension of the Rosemount 3051S Series of Instrumentation and takes full advantage of the scalable architecture. The 3051S SuperModule™ Platform generates the pressure measurement while the diagnostic electronics board is mounted in the PlantWeb housing and plugs into the top of the SuperModule. The electronics board communicates with the SuperModule and produces standard 4 – 20 mA and HART outputs while adding advanced diagnostic capability.

NOTE

When a new SuperModule is connected to the diagnostic electronics board for the first time, the transmitter will be in alarm state until pressure range is specified.

The Advanced HART Diagnostics Suite is designated by the option code “DA2” in the model number. All options can be used with DA2 except the following:

- Foundation Fieldbus protocol (Output code F)
- Wireless (Output code X)
- Quick Connect (Housing code 7J)
- Junction box (Housing code 2A, 2B, 2C, 2J)
- Remote display (Housing code 2E, 2F, 2G, 2M)

The HART Diagnostic transmitter has seven distinct diagnostic functions that can be used separately or in conjunction with each other to detect and alert users to conditions that were previously undetectable, or provide powerful troubleshooting tools.

Rosemount 3051S Series

1. Statistical Process Monitoring (SPM) – SPM technology detects changes in the process, process equipment or installation conditions of the transmitter. This is done by modeling the process noise signature (using the statistical values of mean, standard deviation, and coefficient of variation) under normal conditions and then analyzing the recorded baseline values to current values over time. If a significant change in the current values is detected, the transmitter can generate HART alerts or analog alarms, depending on user configuration. The condition is time stamped and is also noted on the LCD.

The statistical values are also available as secondary variables from the transmitter via HART. Users can trend their process noise signature, perform their own analysis or generate their own alarms or alerts based on the secondary variables. Trending of statistical values in an analog system can be done with the Smart Wireless THUM Adapter or Rosemount 333 Tri-Loop. Refer to pages 7-33 and 7-34 for more details.

2. Power Advisory Diagnostic – This diagnostic functionality detects changes in the characteristics of the electrical loop that may jeopardize loop integrity. This is done by characterizing the electrical loop after the transmitter is installed and powered up in the field. If terminal voltage deviates outside of user configured limits, the transmitter can generate HART alerts or analog alarms.
3. Diagnostic Log – The transmitter logs up to ten device status events, each associated with the time stamp of when the event occurred. Referencing this log allows for better understanding of the device health and can be used in conjunction with device troubleshooting.
4. Variable Log – The transmitter logs the following values: Minimum and Maximum Pressure and Minimum and Maximum Temperature with independent time stamped values. The transmitter also logs total elapsed time in over-pressure or over-temperature conditions and number of pressure or temperature excursions outside of sensor limits.
5. Process Alerts – These are configurable alerts for both process pressure and sensor temperature. Users can receive a HART alert if pressure or temperature exceeds threshold limits. The time stamp of when the alert occurred and the number of alert events is also recorded in the transmitter. When alert is active, this notification is displayed on the LCD.
6. Service Alerts – This is a configurable service reminder that generates a HART alert after user-specified time has expired. When alert is active, this notification is displayed on the LCD.
7. Time Stamp – The diagnostic electronics board includes an embedded Operational Hours clock whose purpose is two-fold.
 - a. Provides the total number of operating hours of the transmitter.
 - b. Provides an elapsed “Time Since” event indication or time stamping for all diagnostics.

All time values are non-volatile and displayed in the following format: YY:DDD:hh:mm:ss (years:days:hours:minutes:seconds). The time stamping capability significantly enhances the user’s ability to troubleshoot measurement issues, particularly transient events that may be too fast to capture with DCS or PLC trending or historian capabilities.

USER INTERFACE

The 3051S with Advanced HART Diagnostic Suite can be used with any asset management software that supports Electronic Device Description Language (EDDL) or FDT/DTM.

Advanced HART Diagnostics is best viewed and configured using the latest Device Dashboard interface based on Human Centered Design concepts. The Device Dashboard can be obtained with DD revision 3051S HDT Dev. 3 Rev. 1.

The following screen shots are taken from Emerson Process Management's AMST™ Device Manager, version 10.5. All screens shown are based on the Device Dashboard interface.

Figure 7-1. Device Dashboard

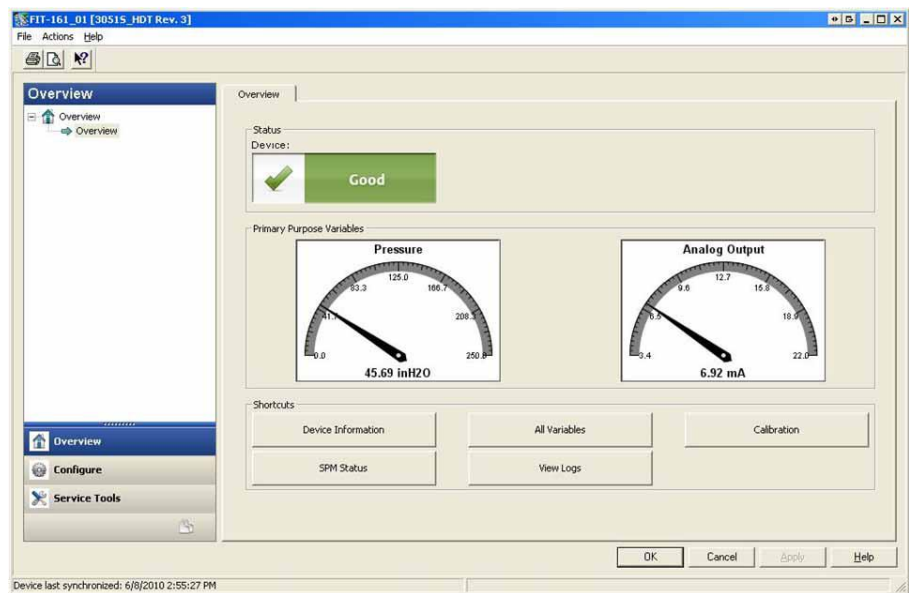

Figure 7-1 is the landing screen for the 3051S with Advanced HART Diagnostic Suite. The device status will change if any device alerts are active. Graphical gauges provide quick reading of the primary purpose variables. Shortcut buttons are available for the most common tasks.

Diagnostic Action Settings

Each diagnostic allows the user to select a type of action to take if the diagnostic is tripped.

None – Transmitter provides no indication that any trip values were exceeded or the diagnostic is turned off.

Alert Unlatched – Transmitter generates digital HART alert and does not affect the 4 – 20 mA signal. When conditions return to normal or within threshold levels, the alert is automatically cleared.

Alert Latched – Transmitter generates digital HART alert and does not affect the 4 – 20 mA signal. When conditions return to normal, an alert reset is required to clear the status. This type of alert action is recommended if a 3rd party alert monitor software is likely to miss alerts due to slow polling of HART data.

Alarm – Transmitter drives mA output to the configured Failure Alarm level (HIGH or LOW).

Rosemount 3051S Series

STATISTICAL PROCESS MONITORING

Introduction

Statistical Process Monitoring (SPM) provides a means for early detection of abnormal situations in a process environment. The technology is based on the premise that virtually all dynamic processes have a unique noise or variation signature when operating normally. Changes in these signatures may signal that a significant change will occur or has occurred in the process, process equipment, or transmitter installation. For example, the noise source may be equipment in the process such as a pump or agitator, the natural variation in the DP value caused by turbulent flow, or a combination of both.

The sensing of the unique signature begins with the combination of the Rosemount 3051S pressure transmitter and software resident in the diagnostic electronics to compute statistical parameters that characterize and quantify the noise or variation. These statistical parameters are the mean, standard deviation, and coefficient of variation of the input pressure. Filtering capability is provided to separate slow changes in the process due to setpoint changes from the process noise or variation of interest. Figure 7-2 shows an example of how the standard deviation value is affected by changes in noise level while the mean or average value remains constant. Figure 7-3 shows an example of how the coefficient of variation is affected by changes in the standard deviation and mean.

The calculation of the statistical parameters within the device is accomplished on a parallel software path used to filter and compute the primary output signal (such as the 4 - 20 mA output). The primary output is not affected in any way by this additional capability.

Figure 7-2. Changes in process noise or variability and affect on statistical parameters

Standard Deviation increases or decreases with changing noise level.

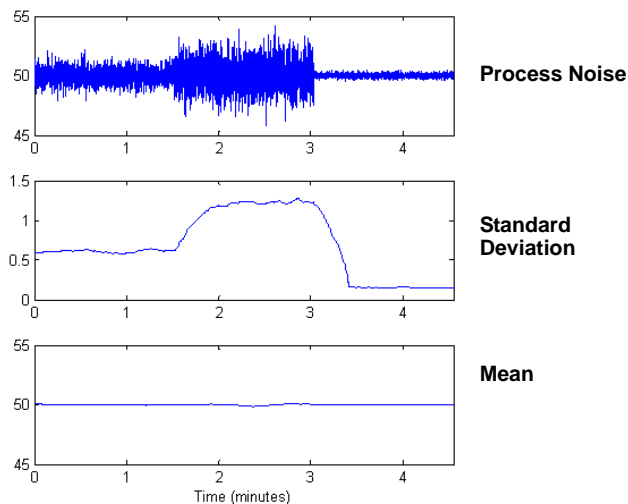
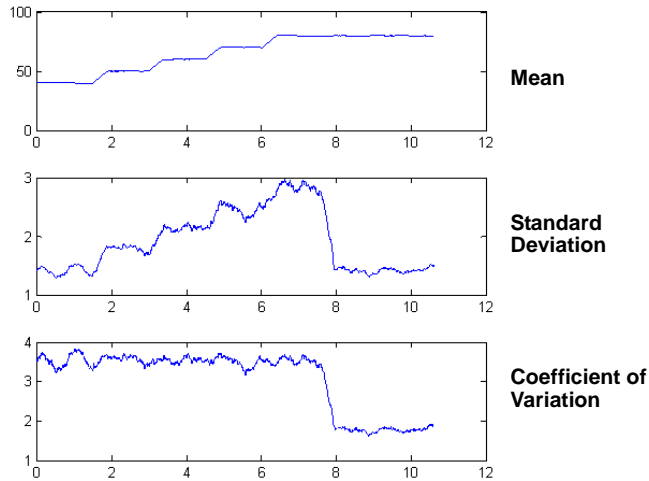

Figure 7-3. CV is the ratio of Standard Deviation to Mean

CV is stable if Mean is proportional to Standard Deviation.



SPM provides statistical information to the user in two ways. First, the statistical parameters can be made available to the host system directly via HART communication protocol or HART to other protocol converters. Once available, the system can make use of these statistical parameters to indicate or detect a change in process conditions. In the simplest example, the statistical values may be stored in a data historian. If a process upset or equipment problem occurs, these values can be examined to determine if changes in the values foreshadowed or indicated the process upset. The statistical values can then be made available to the operator directly, or made available to alarm or alert software.

The second way for SPM to provide statistical information is with software embedded in the 3051S. The 3051S uses SPM to baseline the process noise or signature via a learning process. Once the learning process is completed, the user can set thresholds for any of the statistical parameters. The device itself can then detect significant changes in the noise or variation, and communicate an alarm via the 4 – 20 mA output and/or alert via HART. Typical applications are detection of plugged impulse lines, change in fluid composition, or equipment related problems.

Overview

A block diagram of the SPM diagnostic is shown in Figure 7-4. The pressure process variable is input to a module where basic high pass filtering is performed on the pressure signal. The mean (or average) is calculated on the unfiltered pressure signal, the standard deviation calculated from the filtered pressure signal. These statistical values are available via HART and handheld communication devices like the 375 Field Communicator or asset management software like Emerson Process Management's AMS™ Device Manager. The values can also be assigned as secondary variables from the device for 4-20 mA communication to the user through other devices like the Smart Wireless THUM or Rosemount 333 HART Tri-loop.

Rosemount 3051S Series

Figure 7-4. Statistical Process Monitoring diagnostic resident in transmitter

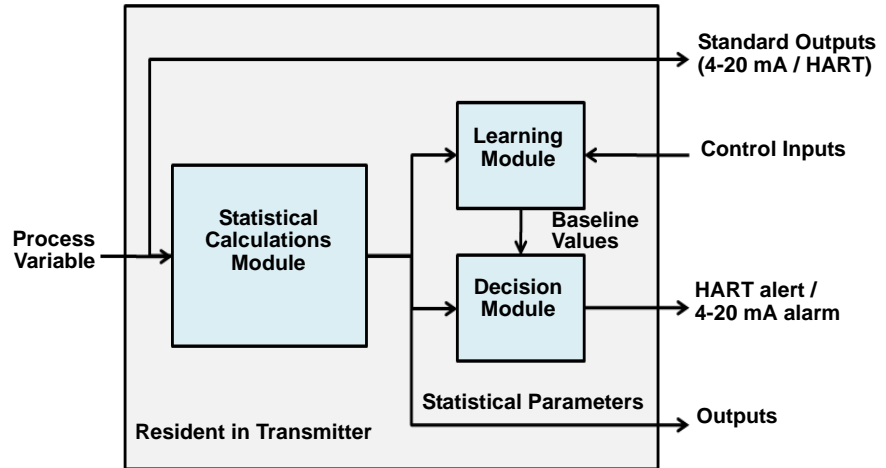

SPM also contains a learning module that establishes the baseline values for the process. Baseline values are established under user control at conditions considered normal for the process and installation. These baseline values are made available to a decision module that compares the baseline values to the most current statistical values. Based on sensitivity settings and actions selected by the user via the control input, the diagnostic generates alarms, alerts, or takes other actions when a significant change is detected in either value.

Figure 7-5. Simplified SPM flowchart

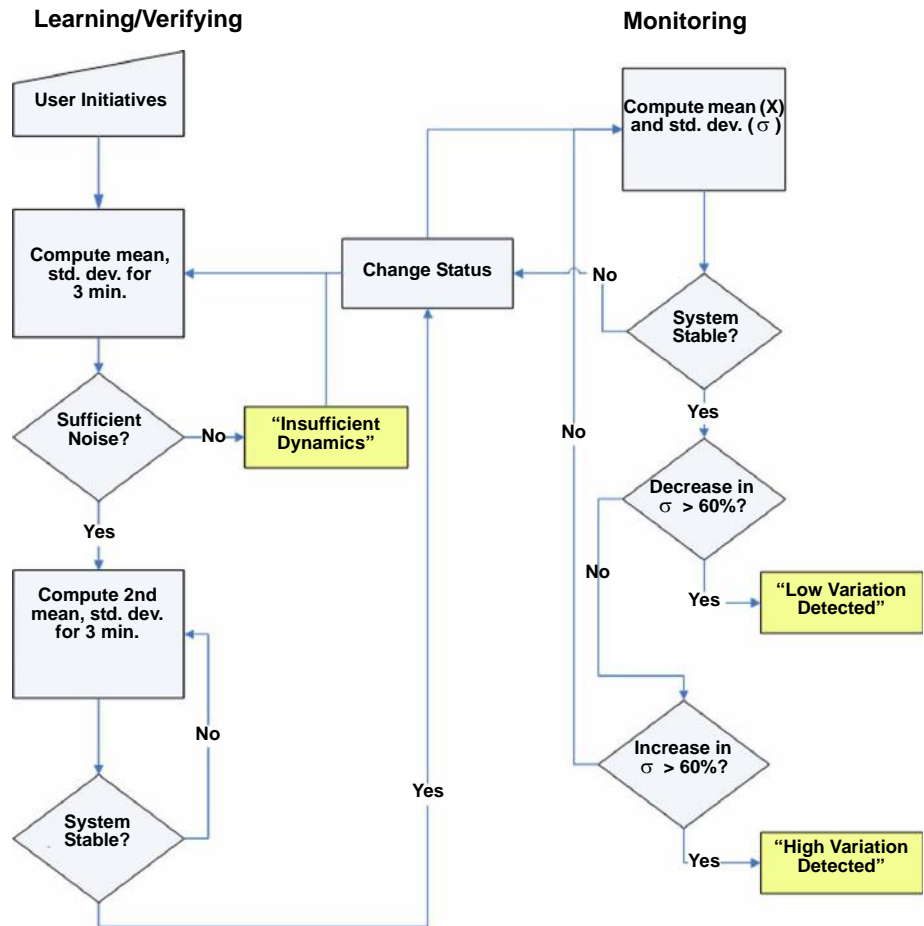

Further detail of the operation of the SPM diagnostic is shown in the Figure 7-5 flowchart. This is a simplified version showing operation using the default values. While SPM continuously calculates the mean, standard deviation, and coefficient of variation values, the learning and decision modules must be turned on to operate. Once enabled, SPM enters the learning/verification mode and the status will be "Learning". The baseline statistical values are calculated over a period of time controlled by the user (Learning/Monitoring Period; default is 3 minutes). A check is performed to make sure that the process has a sufficiently high noise or variability level (above the low level of internal noise inherent in the transmitter itself). If the level is too low, the diagnostic will continue to calculate baseline values until the criteria is satisfied (or turned off). A second set of values is calculated and compared to the original set to verify that the measured process is stable and repeatable. During this period, the status will change to "Verifying". If the process is stable, the diagnostic will use the last set of values as baseline values and change to "Monitoring" status. If the process is unstable, the diagnostic will continue to verify until stability is achieved. The stability criteria are also user defined.

Rosemount 3051S Series

In the “Monitoring” mode, statistical values of mean, standard deviation, and coefficient of variation are continuously calculated, with new values available every second. When using mean and standard deviation as the SPM variables, the mean value is compared to the baseline mean value. If the mean has changed by a significant amount, the diagnostic can automatically return to the “Learning” mode. The diagnostic does this because a significant change in mean is likely due to a change in process operation and can result in a significant change in noise level (i.e. standard deviation) as well. If the mean has not changed, the standard deviation value is compared to the baseline value. If the standard deviation has changed significantly and exceeds configured sensitivity thresholds, this may indicate a change has occurred in the process, equipment, or transmitter installation and a HART alert or analog alarm is generated.

For DP flow applications where the mean pressure is likely to change due to changing process operation, the recommended SPM variable for process diagnostics is the coefficient of variation. Since the coefficient of variation is the ratio of standard deviation to mean, it represents normalized process noise values even when the mean is changing. If the coefficient of variation changes significantly relative to the baseline and exceeds sensitivity thresholds, the transmitter can generate a HART alert or analog alarm.

NOTE

SPM diagnostic capability in the Rosemount 3051S HART pressure transmitter calculates and detects significant changes in statistical parameters derived from the input pressure signal. These statistical parameters relate to the variability of and the noise signals present in the pressure signal. It is difficult to predict specifically which noise sources may be present in a given pressure measurement application, the specific influence of those noise sources on the statistical parameters, and the expected changes in the noise sources at any time. Therefore, Rosemount cannot absolutely warrant or guarantee that SPM will accurately detect each specific condition under all circumstances.

Assigning Statistical Values to Outputs

Device Dashboard Fast Keys	2, 2, 5, 1
-------------------------------	------------

The statistical values of mean, standard deviation, and coefficient of variation can be made available to other systems or data historians via HART communication. WirelessHART adaptor, such as the Smart Wireless THUM can also be used to obtain additional variables. Devices that convert HART variables to analog 4-20 mA outputs, such as the Rosemount 333 Tri-Loop can also be used.

Statistical values can be assigned to be 2nd variable, 3rd variable, or 4th variable. This is accomplished through Variable Mapping. See Figure 7-6.

Figure 7-6. Selection of statistical values as secondary variables

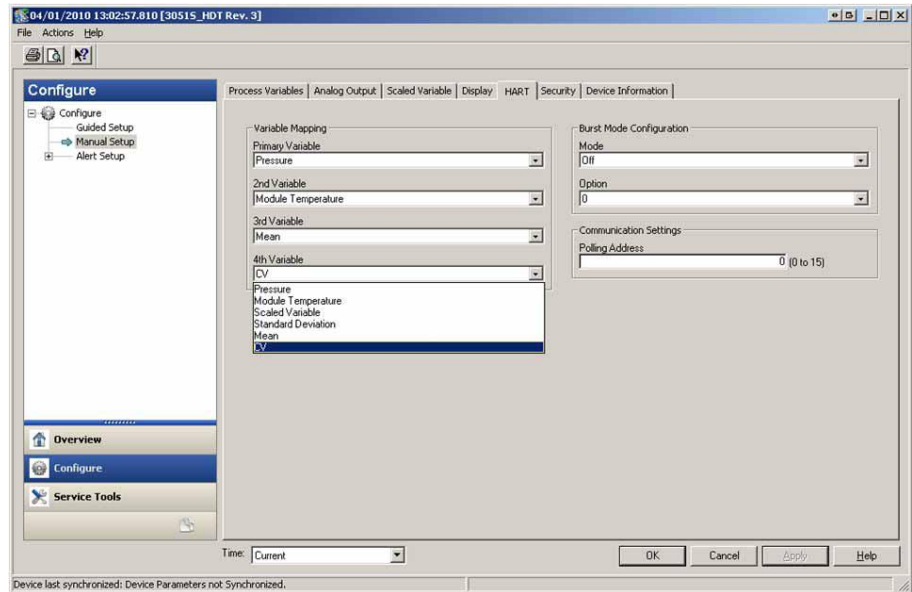

SPM Configuration

Device Dashboard Fast Keys	2, 1, 2, 1
-----------------------------------	------------

For inexperienced users, guided setup is recommended. Guided setup walks the user through settings that configure the SPM diagnostic for most common usage and applications.

Figure 7-7. Guided Setup Menu

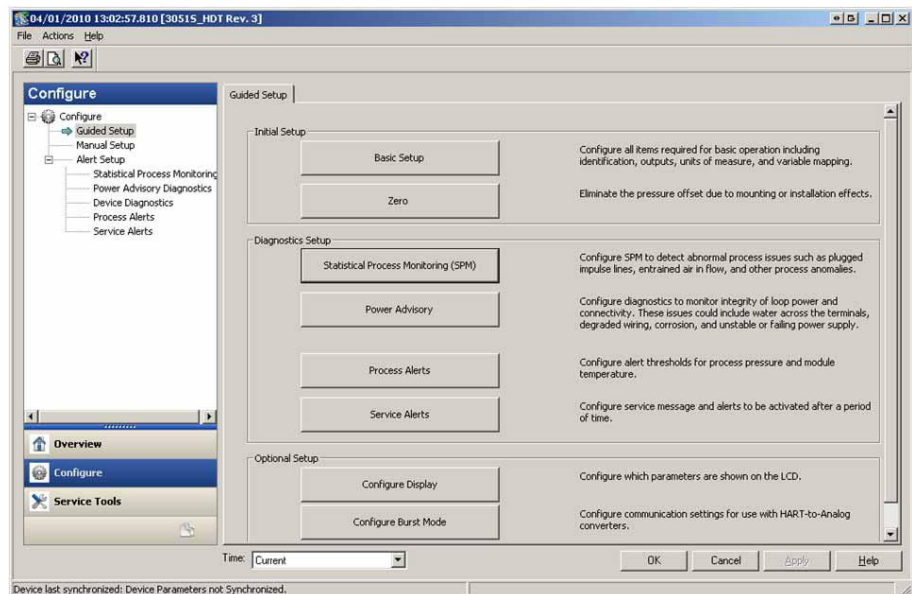

The rest of the configuration section explains the parameters for manual configuration of SPM diagnostic.

Figure 7-8. Statistical Process Monitoring main screen

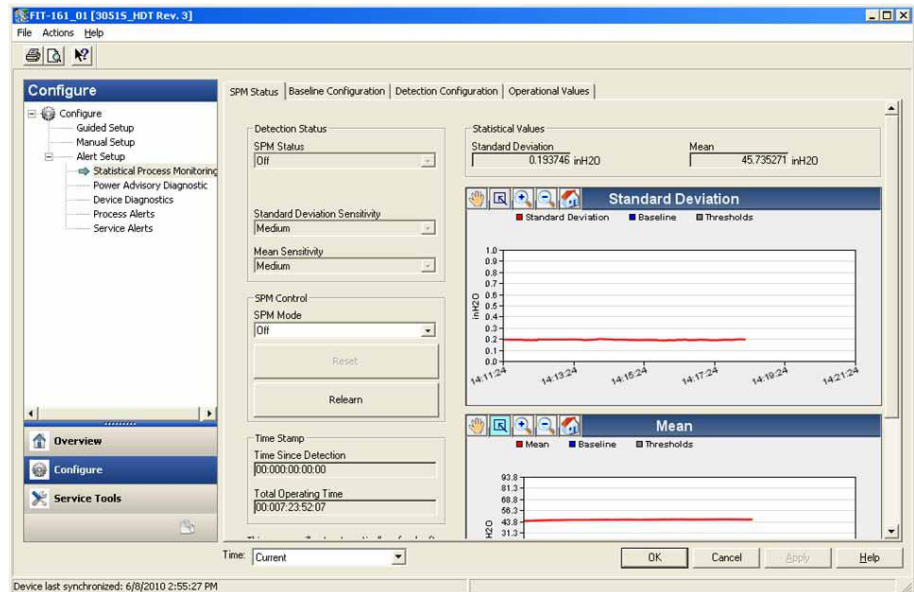

The SPM Status screen shows overview information for the diagnostic.

The process for operation of the SPM diagnostic is:

- Configure the diagnostic using Baseline Configuration and Detection Configuration screens.
- Turn on the diagnostic from the SPM Status screen.

The configuration process starts with Baseline Configuration, Figure 7-9 on page 7-11. The configurable fields are:

SPM Variable:

This is the statistical variable to be used for SPM diagnostic detection.

Stdev & Mean (default)

Standard deviation and mean of the process are calculated. Users can set independent sensitivity thresholds for both statistical variables.

Coefficient of Variation (CV)

CV is calculated from the ratio of standard deviation to mean and is better suited for DP flow applications where the mean pressure is likely to change due to changing process operation. CV puts standard deviation in context of the mean and is represented as a % value.

Figure 7-9. Baseline Configuration screen

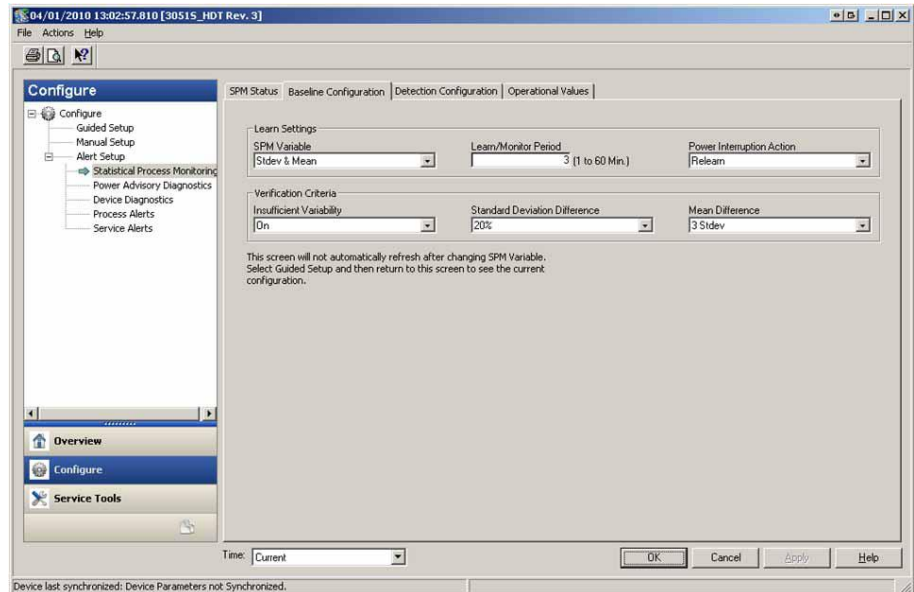

Learn/Monitor Period:

This is the learning and monitoring time period that SPM diagnostic uses to sample the pressure signal. The mean and standard deviation or coefficient of variation values determined during the learning period will become the Baseline values. Decreasing this period can speed up the set up time and is recommended for stable process operations. Increasing this value will give a better baseline value for noisier processes. If false trips for “High Variation Detected” are occurring due to rapid changes in the process and statistical value, increasing the learning period is recommended. The Learning/Monitoring Period is always set in minutes. The default value is 3 minutes and the valid range is 1 to 60 minutes.

Figure 7-10 illustrates the effect of Learn/Monitor Period on the statistical calculations. Notice how a shorter sampling window of 3 minutes captures more variation (e.g. plot looks noisier) in the trend. With the longer sampling window of 10 minutes, the trend looks smoother because SPM uses process data sampled over a longer period of time.

Figure 7-10. Effect of Learn/Monitor Period on Statistical Values

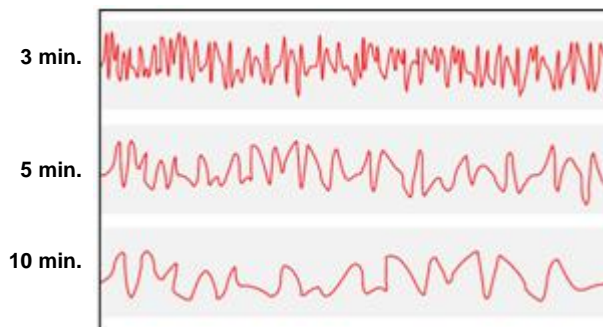

Power Interruption Action

This is used to direct what the diagnostic should do in the case of a power interruption or if the diagnostic is manually disabled and then enabled. The options are:

Monitor (default)

When SPM restarts, the diagnostic returns to the Monitoring mode immediately and uses the baseline values computed before the interruption.

Relearn

When SPM restarts, the diagnostic enters the Learning mode and will recalculate new baseline values.

Low Pressure Cut-off

This is the minimum pressure required to operate the diagnostic with Coefficient of Variation selected as the statistical variable. The coefficient of variation is a ratio of standard deviation to mean and is defined for non-zero mean values. When the mean value is near zero, the coefficient of variation is sensitive to small changes in the mean, limiting its usefulness. Default value is 1% of upper sensor limit.

Insufficient Variability

The SPM diagnostic uses process noise to baseline the process and detect abnormal situations. Typically the Insufficient Variability check is on to ensure there is sufficient noise for proper operation. In a quiet application with very minimal process noise, this setting can be turned off. The default setting is ON.

Parameter	Definition
On (default)	Perform insufficient variation check
Off	Do not perform insufficient variation check

Standard Deviation Difference, Mean Difference

If these difference values are exceeded during the Verification mode, SPM diagnostic will not start Monitoring mode and will continue verifying the baseline. If SPM diagnostic will not leave the Verification mode, these values should be increased. If the diagnostic still remains in the Verification mode with the highest level, the Learning/Monitoring period should be increased.

Table 7-1. Standard Deviation Verification Criteria

Parameter	Definition
None	Do not perform any verification checks for standard deviation.
10%	If the difference between baseline standard deviation value and the verification value exceeds 10%, diagnostic will stay in Verification mode.
20% (default)	If the difference between baseline standard deviation value and the verification value exceeds 20%, diagnostic will stay in Verification mode.
30%	If the difference between baseline standard deviation value and the verification value exceeds 30%, diagnostic will stay in Verification mode.

Table 7-2. Mean Verification Criteria

Parameter	Definition
None	Do not perform any verification checks for mean.
3 Stdev (default)	If the difference between baseline mean value and the verification value exceeds 3 standard deviations, diagnostic will stay in Verification mode.
6 Stdev	If the difference between baseline mean value and the verification value exceeds 6 standard deviations, diagnostic will stay in Verification mode.
2%	If the difference between baseline mean value and the verification value exceeds 2%, diagnostic will stay in Verification mode.

The *Detection Configuration* screen (Figure 7-11 and Figure 7-12) allows for configuration of sensitivity threshold values for tripping the diagnostic and how to receive the HART alert or analog alarm.

Figure 7-11. Detection Configuration screen for Standard Deviation & Mean

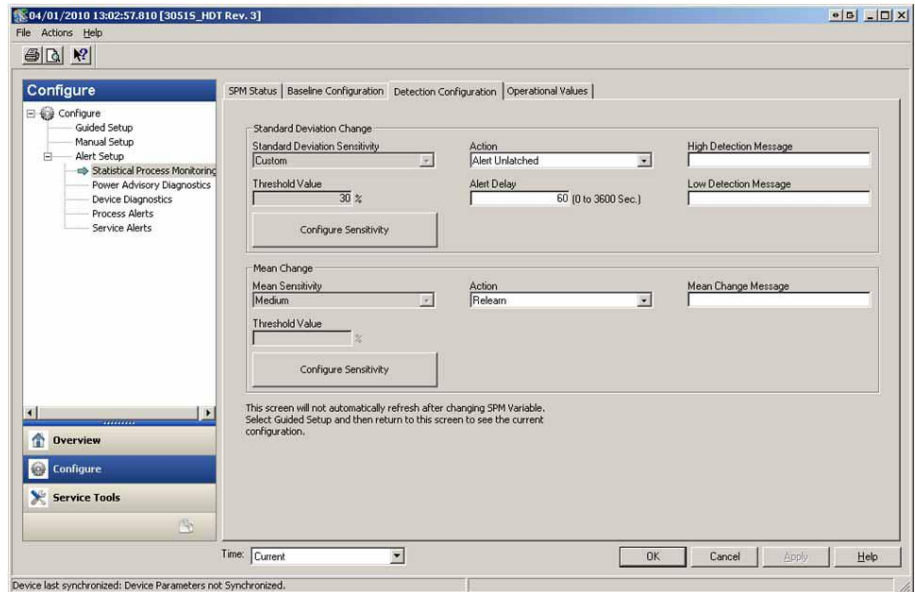
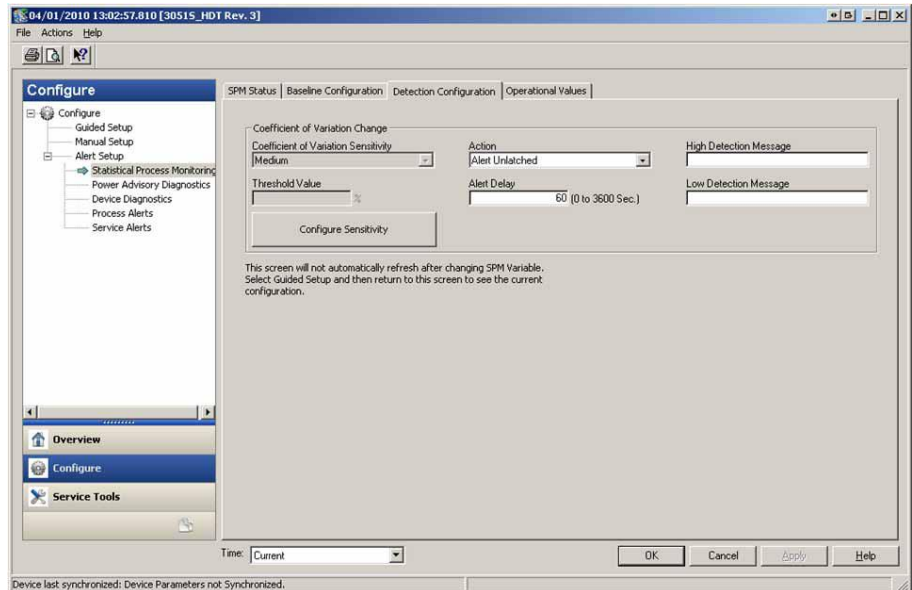

Figure 7-12. Detection Configuration screen for Coefficient of Variation



Standard Deviation Sensitivity, Mean Sensitivity

Shows the current sensitivity level for detecting changes in standard deviation or mean. Users can choose from preset values of High, Medium, and Low. Custom sensitivity levels can also be configured.

Coefficient of Variation Sensitivity

Shows the current sensitivity level for detecting changes in the coefficient of variation. Users can choose from preset values of High, Medium, and Low. Custom sensitivity levels can also be configured.

Figure 7-13 illustrates the differences in preset sensitivity limits of High, Medium, and Low. The preset High sensitivity setting (e.g. 20%) will cause the SPM diagnostic to be more sensitive to changes in the process profile. The preset Low sensitivity setting (e.g. 80%) will cause the SPM diagnostic to be less sensitive as a much greater change in the process profile is needed to trip the alert.

Figure 7-13. Preset sensitivity levels

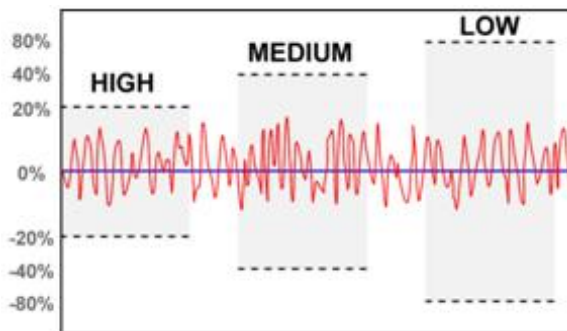

Threshold Value

If sensitivity is Custom, this field will display the custom sensitivity setting as % change from the baseline value.

Configure Sensitivity

This button launches a window for entering sensitivity settings.

Table 7-3. Standard Deviation Sensitivity Choices

Parameter	Definition
Low	80% change from baseline value will trip the diagnostic
Medium (default)	60% change from baseline value will trip the diagnostic
High	40% change from baseline value will trip the diagnostic
Custom	Adjustable from 1 to 10000%

Table 7-4. Mean Sensitivity Choices

Parameter	DP	GP/AP
Low	40% of baseline or 4% of span, whichever is greater	20% of span
Medium (default)	20% of baseline or 2% of span, whichever is greater	10% of span
High	10% of baseline or 1% of span, whichever is greater	5% of span
Custom	Adjustable from 1 to 10000% of value	Adjustable from 1 to 10000% of span

Table 7-5. Coefficient of Variation Sensitivity Choices

Parameter	Definition
Low	80% change from baseline value will trip the diagnostic
Medium (default)	40% change from baseline value will trip the diagnostic
High	20% change from baseline value will trip the diagnostic
Custom	Adjustable from 1 to 10000%

Alert Delay

This value specifies the amount of delay from when the transmitter detects a deviation of the sensitivity threshold to generating an alert or alarm. The default value is 60 seconds and valid range is 0 to 3600 seconds. Increasing the alert delay helps to avoid false detections resulting from the standard deviation or CV exceeding the threshold only momentarily.

High Detection Message

Customizable message field related to standard deviation / coefficient of variation crossing the upper threshold value. This message can be used to describe the abnormal process condition or provide additional details for troubleshooting. Message will appear along with the High Variation or High CV Detected alert. Character limit is 32 including spaces.

Low Detection Message

Customizable message field related to standard deviation / coefficient of variation crossing the lower threshold value. This message can be used to describe the abnormal process condition or provide additional details for troubleshooting. Message will appear along with the Low Variation or Low CV Detected alert. Character limit is 32 including spaces.

Mean Change Message

Customizable message field related to mean value crossing either the upper or lower threshold value. This message can be used to describe the abnormal process condition or provide additional details for troubleshooting. Message will appear along with the Mean Change Detected alert. Character limit is 32 including spaces.

Operation

Device Dashboard Fast Keys	1, 3, 2
---------------------------------------	---------

Figure 7-14. SPM diagnostic can be activated from the SPM Status screen

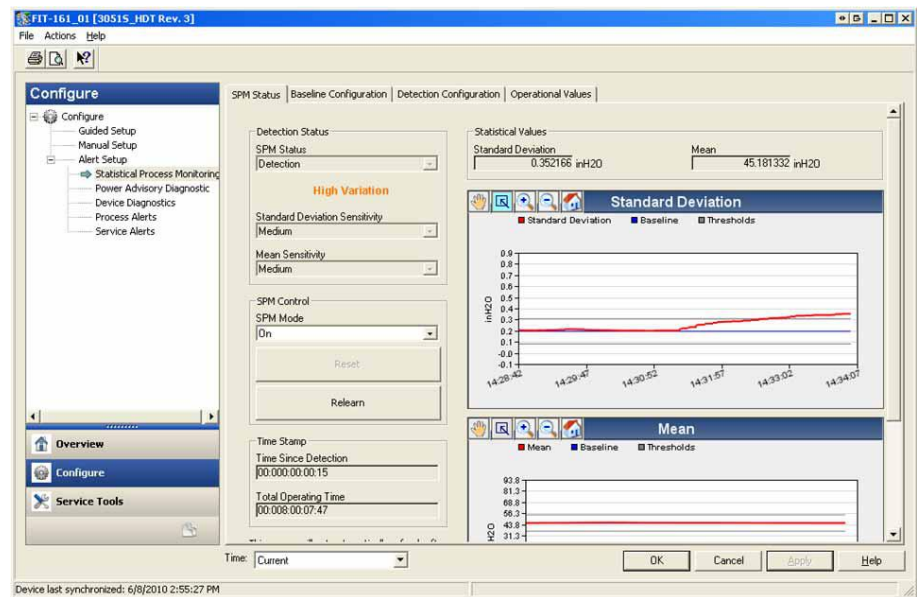

Turning On the SPM Diagnostic

The SPM diagnostic is enabled by selecting On for “SPM Mode”, shown on Figure 7-14. Upon enabling SPM, the diagnostic will automatically begin “Learning” with the following exception: if valid baseline values have been previously established and “Monitor” has been selected as the option for Power Interruption on the Baseline Configuration screen, then the diagnostic will bypass Learning and begin Monitoring immediately. The diagnostic status will stay in the Learning mode for the Learning Period specified on the Baseline Configuration screen. After the learning period is complete, the Mode will change to Verifying and a blue line will appear on the charts indicating the learned baseline value. Upon completion of the Verify mode, the diagnostic will use the parameters selected on the Verification Criteria page to validate the baseline value. After the Verifying period the Mode will switch to Monitoring and grey lines that indicate the sensitivity setting will appear on the charts.

Reset

If SPM trip action is set to “Alert Latched”, clicking on Reset will clear the alert when process conditions are back to normal or baseline.

Relearn

Clicking this button will cause SPM to relearn the process condition and establish a new baseline. Manually performing a relearn is recommended if the process profile has been intentionally changed to a new set point.

Figure 7-15. Operational Values screen

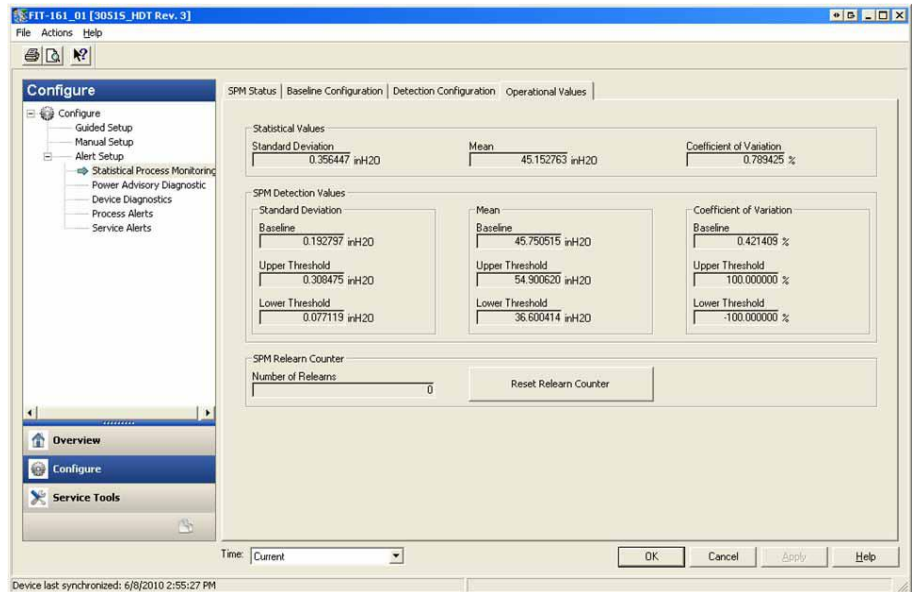

The Operational Values screen contains the parameter values used in the SPM diagnostic.

Standard Deviation

This is the current value of standard deviation. This value is continuously calculated and can be provided as a secondary variable.

Mean

This is the current value of mean. This value is continuously calculated and can be provided as a secondary variable.

Coefficient of Variation

This is the current value for coefficient of variation. The CV is derived from the ratio of standard deviation to mean. This value is continuously calculated and can be provided as a secondary variable.

Number of Relearns

This is the number of times SPM relearn has been initiated by the user or via automatic relearn.

Detection

If the SPM diagnostic detects a Standard Deviation, Mean, or Coefficient of Variation change outside the threshold values, the SPM Status box will indicate “Detection”, followed by the type of detection.

Rosemount 3051S Series

The LCD will also indicate the diagnostic condition. The “Time Since Detection” clock in the Time Stamp box will start incrementing until the statistical value is returned to normal. If the diagnostic alert is latched, the “Time Since Detection” clock will continue to increment until the alert is reset or SPM diagnostic is turned off.

Interpreting Results

The SPM diagnostic can be used to detect installation, process and equipment changes, or problems. However, as the diagnostic is based on detecting changes in process noise or variability, there are many possible reasons or sources for the change in values and detection. Following are some possible causes and solutions if a diagnostic event is detected:

Table 7-6. Possible causes of SPM diagnostic events

Detection Type	LCD Display	Potential Cause	Corrective Action
High Variation Detected / High CV Detected	HIGH VARIA / HIGH CV	Plugged impulse line (DP only).	Follow facility procedure to check for and clear plugged impulse lines. Both lines must be checked as the SPM diagnostic cannot determine if the plug is on the high or low side. Conditions that lead to plugging on one side may lead to an eventual plug on the other side.
		Aeration or aeration increase (liquid flow).	a) If aeration is undesired, take necessary steps to eliminate aeration. b) If the measurement is DP flow and aeration is not desired, move primary element to another location in the process piping to ensure it remains full (no air) under all conditions.
		Liquid present or amount of liquid increased (gas or steam flow).	If liquid is undesired, take necessary steps to eliminate liquid in gas or steam flow. If some liquid is normal, and error correction in the gas flow measurement is being done (such as an over-reading in wet natural gas measurements), you may need to determine the volume fraction of the liquid (e.g. using a test separator) and a new error correction factor for the gas flow measurement.
		Solids present or solids level increased.	If solids are undesired, take necessary steps to eliminate.
		Control loop problem (valve stiction, controller issue, etc.).	Review control valve or loop for control problems.
		Process or equipment change or problem has resulted in an increase in the pressure noise level.	Check process equipment.
High Variation Detected	HIGH VARIA	Rapid change of process variable mean value.	Rapid changes in the process variable can result in indication of high variation. If undesired, increase Alert Delay value (default is 60 seconds). Increase the Learn/Monitor period (default is 3 minutes).

Table 7-6. Possible causes of SPM diagnostic events

Detection Type	LCD Display	Potential Cause	Corrective Action
Low Variation Detected / Low CV Detected	LOW VARIA / LOW CV	Plugged impulse line (DP/AP/GP).	Follow facility procedure to check for and clear plugged impulse lines. Both lines must be checked as the SPM diagnostic cannot determine if the plug is on the high or low side (DP devices only). Conditions that lead to plugging on one side may lead to an eventual plug on the other side.
		Aeration decrease.	If decrease is normal, reset and relearn. If not, check process and equipment for change in operating conditions.
		Decrease of liquid content in gas or steam flow.	If decrease is normal, reset and relearn. If not, check process and equipment for change in operating conditions.
		Decrease in solids content.	If decrease is normal, reset and relearn. If not, check process and equipment for change in operating conditions.
		Reduction in variability in process.	If decrease is normal, reset and relearn. If not, check process and equipment for change in operating conditions. For example, a stuck control valve can reduce variability.
Mean Change Detected	MEAN CHANGE	Significant process setpoint change.	If change is normal, reset and relearn. Consider changing mean change detection to automatically relearn. If change is not expected, check process and equipment for change in operating conditions.

NOTE

Rosemount cannot absolutely warrant or guarantee that Statistical Process Monitoring will accurately detect each specific abnormal condition under all circumstances. Standard maintenance procedures and safety precautions should not be ignored because SPM diagnostic is enabled.

Troubleshooting the SPM Diagnostic

Users are encouraged to pretest the SPM diagnostic if possible. For example, if the diagnostic is to be used to detect plugged impulse lines, and if root valves are present in the installation, the user should set up the diagnostic as described earlier, and then alternately close the high and the low side root valve to simulate a plugged impulse line. Using the SPM Status screen, the user can then note the changes to the standard deviation or coefficient of variation under the closed conditions and adjust the sensitivity values as needed.

Table 7-7. Possible SPM issues and resolutions

SPM Diagnostic Issue	Action
SPM diagnostic status indicates insufficient variability and will not leave learning or verifying mode	Process has very low noise. Turn off insufficient variability check (Verification Criteria screen). SPM diagnostic will be unable to detect a significant decrease in noise level.

Table 7-7. Possible SPM issues and resolutions

SPM Diagnostic Issue	Action
SPM diagnostic will not leave verifying mode	Process is unstable. Increase learning sensitivity checks (Verification Criteria screen). If this does not correct the issue, increase the learning verification period to match or exceed the cycle time of the instability of the process. If maximum time does not correct the problem, process is not a candidate for SPM diagnostic. Correct stability issue or turn off diagnostic.
SPM diagnostic does not detect a known condition	With the condition present, but the process operating, go to the SPM Status or Operational Values screen and note the current statistical values and compare to the baseline and threshold values. Adjust the sensitivity values until a trip of the diagnostic occurs.
SPM diagnostic indicates "High Variation Detected" when no diagnostic event has occurred	The most likely cause is a fast change in the value of the process variable. Direction of the change is not important. Increase the learning/monitoring period to better filter out increases in standard deviation.

POWER ADVISORY

Introduction

The Power Advisory diagnostic provides a means to detect issues that may jeopardize the integrity of the electrical loop. Some examples are: water entering the wiring compartment and makes contact with the terminals, an unstable power supply nearing end of life, or heavy corrosion on the terminals.

This technology is based on the premise that once a transmitter is installed and powered up, the electrical loop has a baseline characteristic that reflects the proper installation. If the transmitter terminal voltage deviates from the baseline and outside the user configured threshold, the 3051S can generate a HART alert or analog alarm.

To make use of this diagnostic, the user must first create a baseline characteristic for the electrical loop after the transmitter has been installed. The loop is automatically characterized with the push of a button. This creates a linear relationship for expected terminal voltage values along the operating region from 4 – 20 mA, see Figure 7-16.

Figure 7-16. Baseline operating region

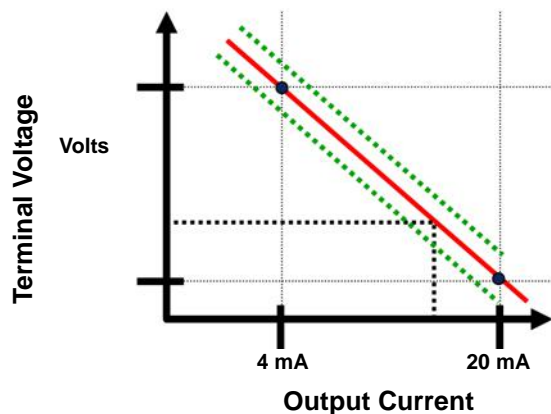

Overview

The transmitter is shipped with Power Advisory off as default and without any loop characterization performed. Once the transmitter is installed and powered up, loop characterization must be performed for Power Advisory diagnostic to function.

When the user initiates a loop characterization, the transmitter will check to see if the loop has sufficient power for proper operation. Then the transmitter will drive the analog output to both 4mA and 20mA to establish a baseline and determine the maximum allowable terminal voltage deviation. Once this is complete, the user enters a sensitivity threshold called "Terminal Voltage Deviation Limit" and a check is in place to make sure this threshold value is valid.

Once the loop has been characterized and Terminal Voltage Deviation Limit is set, Power Advisory actively monitors the electrical loop for deviations from the baseline. If the terminal voltage has changed relative to the expected baseline value, exceeding the configured Terminal Voltage Deviation Limit, the transmitter can generate an alert or alarm.

NOTE

Power Advisory diagnostic in the Rosemount 3051S HART pressure transmitter monitors and detects changes in the terminal voltage from expected values to detect common failures. It is not possible to predict and detect all types of electrical failures on the 4-20mA output. Therefore, Rosemount cannot absolutely warrant or guarantee that Power Advisory Diagnostic will accurately detect failures under all circumstances.

Configuration

Device Dashboard Fast Keys	2, 1, 2, 2
---------------------------------------	------------

For inexperienced users, guided setup is recommended. Guided setup walks the user through settings that configure the Power Advisory diagnostic for most common usage and applications.

Figure 7-17. Guided Setup Menu

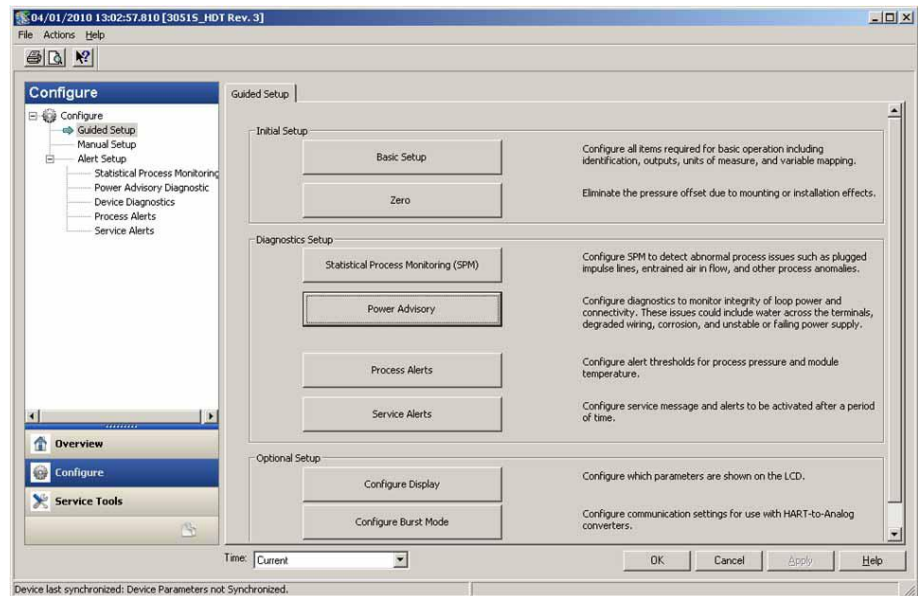

The rest of the configuration section explains the parameters for manual configuration of Power Advisory diagnostic.

Figure 7-18. Manual configuration of Power Advisory main screen

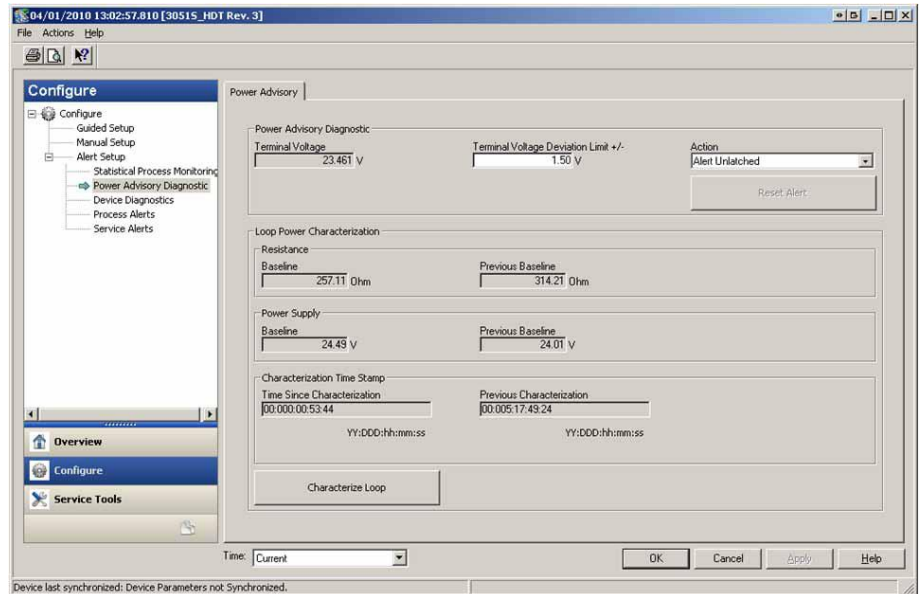

The Power Advisory configuration screen allows users to characterize the loop and configure the Terminal Voltage Deviation Limit and the Action. Two instances of loop characterization data are recorded and presented on this screen: “Baseline” and “Previous Baseline”. Baseline represents values from the most recent loop characterization whereas Previous Baseline represents values recorded prior to the most recent characterization.

Terminal Voltage

This field shows the current terminal voltage value in Volts. The terminal voltage is a dynamic value and is directly related to the mA output value.

Terminal Voltage Deviation Limit +/-

The Terminal Voltage Deviation Limit should be set large enough that “expected” voltage changes do not cause false failures. The default value of 1.5V will accommodate typical deviation of customer power supply voltage and loop tests (amp meters connected across the test diode on the terminal block). This value should be increased if your loop has additional “expected” variation.

Figure 7-19. Voltage Deviation Limit

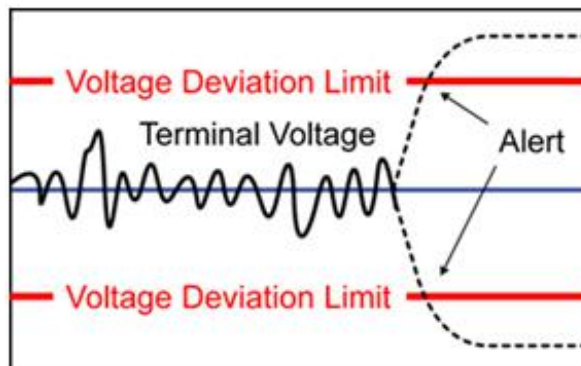

⚠ WARNING

Severe changes in the electrical loop may inhibit HART communication or the ability to reach alarm values. Therefore, Rosemount cannot absolutely warrant or guarantee that the correct Failure Alarm level (HIGH or LOW) can be read by the host system at the time of annunciation.

Resistance

This value is the calculated resistance of the electrical loop (in Ohms) measured during the Characterize Loop procedure. Changes in the resistance may occur due to changes in the physical condition of the loop installation. Baseline and Previous Baselines can be compared to see how much resistance has changed over time.

Power Supply

This value is the calculated power supply voltage of the electrical loop (in Volts) measured during the Characterize Loop procedure. Changes in this value may occur due to degraded performance of the power supply. Baseline and Previous Baselines can be compared to see how much the power supply has changed over time.

Characterization Time Stamp

This is the time stamp or elapsed time of the loop characterization event. All time values are non-volatile and displayed in the following format: YY:DDD:hh:mm:ss (years:days:hours:minutes:seconds).

Characterize Loop

Loop characterization must be initiated when the transmitter is first installed or when electrical loop characteristics have been intentionally altered. Examples include more transmitters being added onto the loop, modified power supply level or loop resistance of the system, changing the terminal block on the transmitter, or adding the Smart Wireless THUM to the transmitter. Another case of required re-characterization is if the diagnostic electronics is taken out of an existing 3051S transmitter and placed in a new 3051S installed on a different loop.

NOTE

Power Advisory diagnostic is not recommended for transmitters operating in HART Burst Mode (fixed current mode) or multidrop.

Rosemount 3051S Series

Troubleshooting

Table 7-8. Possible Power Advisory issues and resolutions

Issue	Resolution
Transmitter automatically resets upon annunciation of HIGH alarm.	The loop has been severely degraded and the transmitter does not have enough voltage to generate a HIGH alarm. Transmitter reset will create a low off-scale reading. Repair damaged loop.
Transmitter does not generate LOW alarm value when it should.	The loop has been severely degraded and the host system is not able to read the proper mA output from the transmitter. This may occur if water floods the terminal compartment and “shorts out” the + to – terminals or the terminals to chassis. This is most likely to occur if the loop resistor is connected to the + side of the power supply. Repair the damaged loop. Consider setting alarm direction to HIGH.
Transmitter does not generate HIGH alarm value.	The loop has been severely degraded and the host system is not able to read the proper mA output from the transmitter. This may occur if water floods the terminal compartment and “shorts out” the + to – terminals or the terminals to chassis. This is most likely to occur if the loop resistor is connected to the – side of the power supply and is earth grounded. Repair the damaged loop. Consider setting alarm direction to LOW.
Diagnostic does not detect a damaged loop.	Diagnostic will not trip if loop characterization was performed when the loop was already damaged. Repair damaged loop and re-characterize.
Diagnostic is detecting false alarms or alerts.	Re-characterize the loop and compare the baseline with the previous baseline. Resistance changes may indicate poor or intermittent connections. Power supply voltage changes may indicate unstable supply. Test for the presence of AC voltage using an AC DVM or oscilloscope. Adding an amp meter across the test diode will cause voltage changes of up to 1V. If all conditions look acceptable, increase the terminal voltage deviation.

DIAGNOSTIC LOG

Device Dashboard Fast Keys	3, 4, 2
-------------------------------	---------

Overview

The Diagnostic Log provides a history of the last ten transmitter alerts and time stamp of when they occurred. This allows the user to reference a sequence of events or alerts to aid the troubleshooting process. The log prioritizes and manages the alerts in a first-in, first-out manner. This log is stored in the non-volatile internal memory of the 3051S transmitter. If power is removed from transmitter, the log remains intact and can be viewed again when powered up.

Figure 7-20. Diagnostic Log

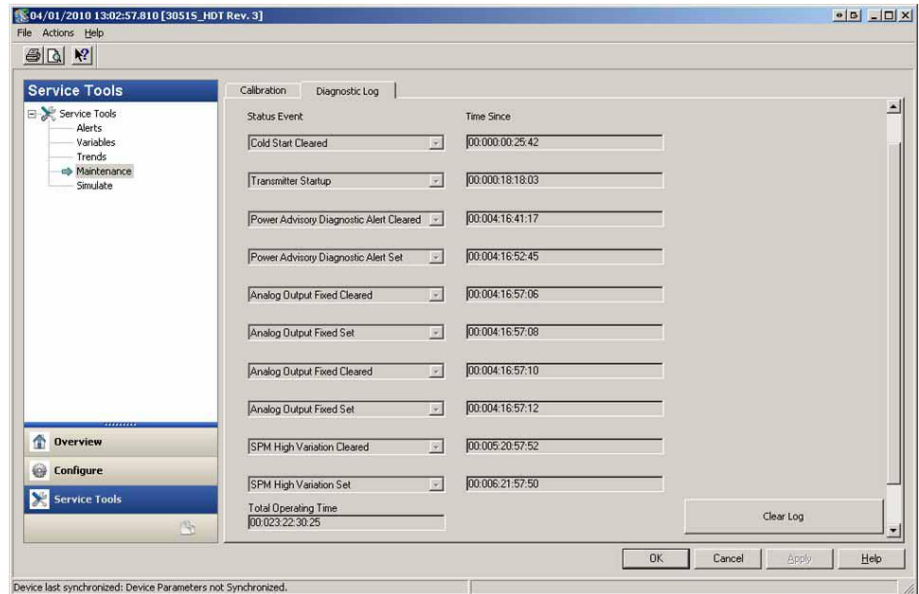

Figure 7-20 shows the Diagnostic Log screen where a set of ten events and time stamp can be seen.

Status Event

This is the name of the event that was recorded in the transmitter. Table 7-9 shows a list of possible status events that can be recorded.

Table 7-9. Possible status events for Diagnostic Log

Alert / Status	Criticality
CPU Error Set, Cleared	Failed
Electronics Failure Set, Cleared	Failed
Field Device Malfunction Set, Cleared	Failed
HW/SW Incompatibility Set, Cleared	Failed
mA Output Diagnostic Alert Set, Cleared	Failed
NV Error Set, Cleared	Failed
Pressure Not Updating Set, Cleared	Failed
RAM Error Set, Cleared	Failed
ROM Error Set, Cleared	Failed
Sensor Failure Set, Cleared	Failed
Stack Overflow Set, Cleared	Failed
SW Flow Control Error Set, Cleared	Failed
Transmitter Power Consumption Alert Set, Cleared	Failed
Analog Output Fixed Set, Cleared	Maintenance
Analog Output Saturated Set, Cleared	Maintenance
Power Advisory Diagnostic Alert Set, Cleared	Maintenance
Pressure Out of Limits Set, Cleared	Maintenance
Sensor Trim Mode Set, Cleared	Maintenance
Temperature Compensation Error Set, Cleared	Maintenance
Temperature Not Updating Set, Cleared	Maintenance
Cold Start Cleared	Advisory
High CV Change Set, Cleared	Advisory
Key Error Set, Cleared	Advisory
LCD Update Error Set, Cleared	Advisory

Rosemount 3051S Series

Table 7-9. Possible status events for Diagnostic Log

Alert / Status	Criticality
Low CV Change Set, Cleared	Advisory
New Sensor Set, Cleared	Advisory
Pressure Alert Set, Cleared	Advisory
Scaled Variable Low Flow Set, Cleared	Advisory
Service Alert Set, Cleared	Advisory
SPM High Variation Set, Cleared	Advisory
SPM Low Pressure Cutoff Set, Cleared	Advisory
SPM Low Variation Set, Cleared	Advisory
SPM Mean Change Detected Set, Cleared	Advisory
Stuck Key Set, Cleared	Advisory
Temperature Alert Set, Cleared	Advisory
Temperature Out of Limits Set, Cleared	Advisory
Transmitter Startup	Advisory

NOTE:

It is recommended that transmitters showing “Failed” status should be replaced.

Time Since

This is the time stamp or elapsed time of the status event. All time values are non-volatile and displayed in the following format: YY:DDD:hh:mm:ss (years:days:hours:minutes:seconds).

Clear Log

This button launches a method to clear the status events in the Diagnostic Log.

VARIABLE LOGGING

Overview

Variable Logging can be used in a number of ways. The first function is the logging and time-stamping of the minimum and maximum pressures and module temperatures. The second function is logging and time-stamping of over pressure or over temperature conditions, events that could have an effect on the life of the transmitter. Figure 7-21 shows the Pressure Variable Logging screen. Figure 7-22 shows the Temperature Variable Logging screen.

Pressure Variable Log

Device Dashboard Fast Keys	3, 2, 2
-------------------------------	---------

Minimum, Maximum Pressure

The meters indicate the lowest and highest pressure the transmitter has measured since the last time the value was cleared. Time Since Event indicates the elapsed time since the min/max pressure was measured.

Both the Min and Max values can be reset independently. Clicking on Reset All Pressure Events will reset the Time Since Event clock and sets the pressure to the currently measured value.

Figure 7-21. Pressure Variable Logging screen

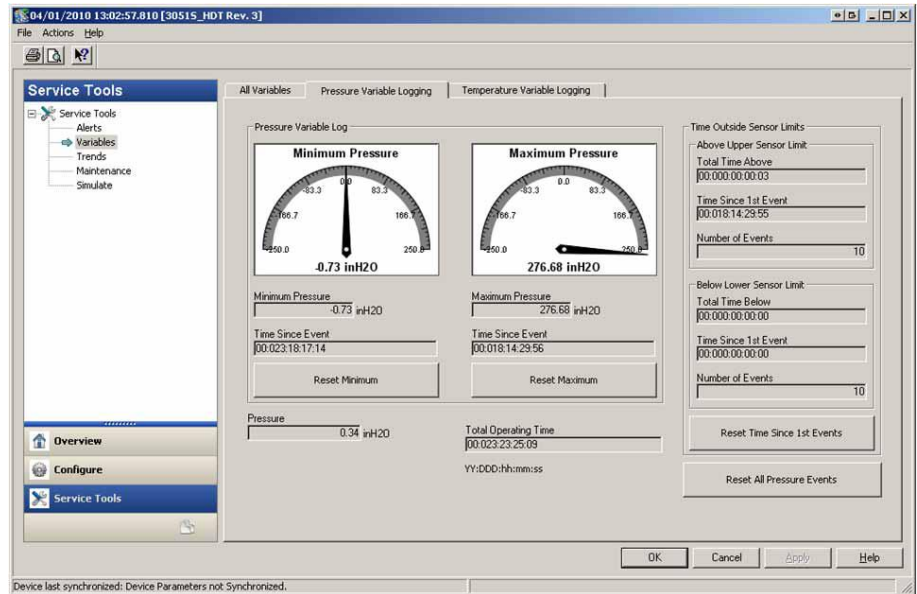

Time Outside Sensor Limits gives the operator/maintenance personnel an indication of possible misapplication of the transmitter. The Lower and Upper operate the same. They both include a Time Since 1st Event, Number of Events, and Total time.

Total Time Above / Below

This is the accumulated time the pressure sensor has been in an over-pressure condition. This elapsed total time is independent of the number of events or frequency; it is the total or sum time the transmitter was in this condition. These values are not resettable.

Time Since 1st Event

The elapsed time since the first over-pressure was detected. This time can be reset by clicking the Reset Time Since 1st Events button.

Number of Events

This is the number of times the pressure sensor has been in an over-pressure condition. These values are not resettable.

Reset Time Since 1st Events

Selecting this reset will set the Since 1st Event for both Above Upper Sensor Limit and Below Lower Sensor Limit to zero.

Reset All Pressure Events

Selecting this will reset all values on this screen to zero with the exception of Total Operating Time, the Total Time above and below sensor limit, and the Number of Events for above and below sensor limit.

Rosemount 3051S Series

Temperature Variable Log

Device Dashboard Fast Keys	3, 2, 3
-------------------------------	---------

Minimum, Maximum Temperature

The meter indicates the lowest and highest temperature the transmitter has measured since the last time the value was cleared. The Time Since Event indicates the elapsed time since that temperature was measured.

Both the Min and Max values can be reset independently. Clicking on Reset All Temperature Events will reset the Time Since Event clock and sets the temperature to the currently measured value.

Figure 7-22. Temperature Variable Logging screen

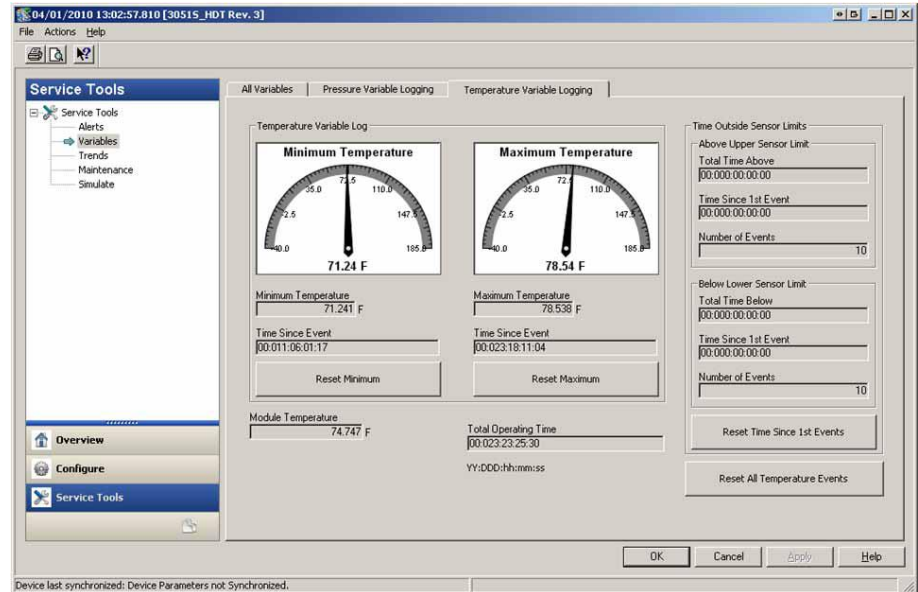

Time Outside Sensor Limits gives the operator/maintenance personnel an indication of possible misapplication of the transmitter. The Lower and Upper operate the same. They both include a Time Since 1st Event, Number of Events, and Total time.

Total Time Above / Below

This is the accumulated time the temperature sensor has been in an over-temperature condition. This elapsed total time is independent of the number of events or frequency; it is the total or sum time the transmitter was in this condition. These values are not resettable.

Time Since 1st Event

The elapsed time since the first over- temperature was detected. This time can be reset by clicking the Reset Time Since 1st Events button.

Number of Events

This is the number of times the temperature sensor has been in an over-temperature condition. These values are not resettable.

Reset Time Since 1st Events

Selecting this reset will set the Since 1st Event for both Above Upper Sensor Limit and Below Lower Sensor Limit to zero.

Reset All Temperature Events

Selecting this will reset all values on this screen to zero with the exception of Total Operating Time, the Total Time above and below sensor limit, and the Number of Events for above and below sensor limit.

PROCESS ALERTS

Overview

Process alerts can be used in addition to alarm or alerts generated in the control system to indicate problems with the process or installation.

Pressure Alerts

Device Dashboard Fast Keys	2, 3, 4, 1
-------------------------------	------------

Figure 7-23. Process Pressure Alerts screen

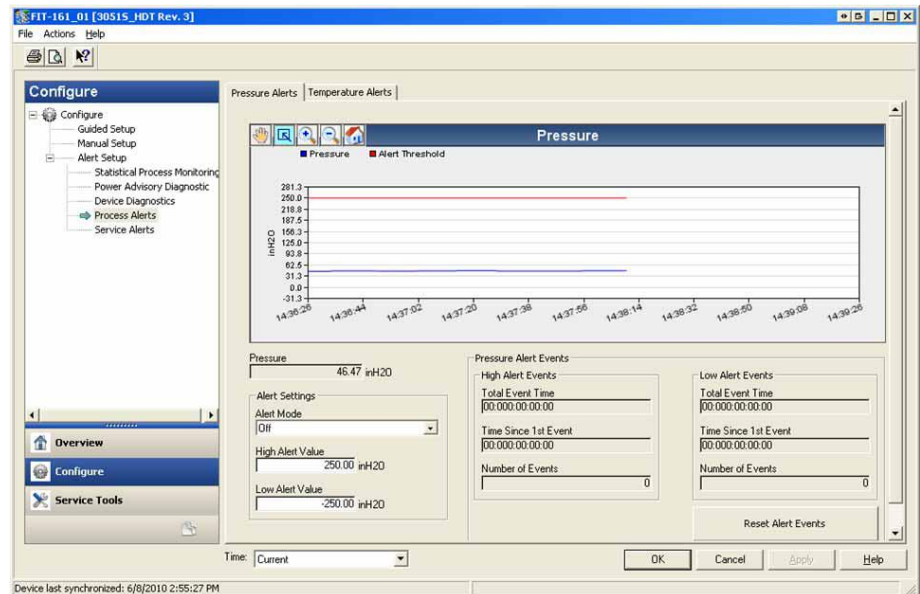

Figure 7-23 shows the configuration section for Pressure Alert. If applied pressure goes above or below the alert values, the LCD will indicate a pressure alert and a HART alert will be generated by the transmitter. An active alert will not affect the transmitter’s 4 – 20 mA output signal.

Alert Mode

This setting dictates whether the diagnostic is On or Off. Selecting “On Unlatched” will generate a HART alert when the alert values are tripped. When pressure returns to normal and within the alert limits, the alert is automatically cleared. Selecting “On Latched” will generate the same HART alert but will require a manual reset to clear the alert.

Latched alert action is recommended if 3rd party alert monitor software is likely to miss alerts due to slow polling of HART data.

High Alert Value / Low Alert Value

These are independent trip values for the diagnostic. These values are represented on the graph by the red lines.

Total Event Time (High / Low)

These fields show the total time the transmitter’s input pressure was above the High Alert Value or below the Low Alert Value.

Time Since 1st Event (High / Low)

This is the elapsed time since the first Pressure Alert event for High Alert Value and Low Alert Value. Subsequent events will increment the Total Event Time values but this value will remain unchanged.

Number of Events (High / Low)

This is the number of times the transmitter’s input pressure was above the High Alert Value or below the Low Alert Value.

Reset Alert Events

Selecting this will reset all time stamp values and number of events to zero.

Temperature Alerts

Device Dashboard Fast Keys	2, 3, 4, 2
-----------------------------------	------------

Figure 7-24. Module Temperature Alert screen

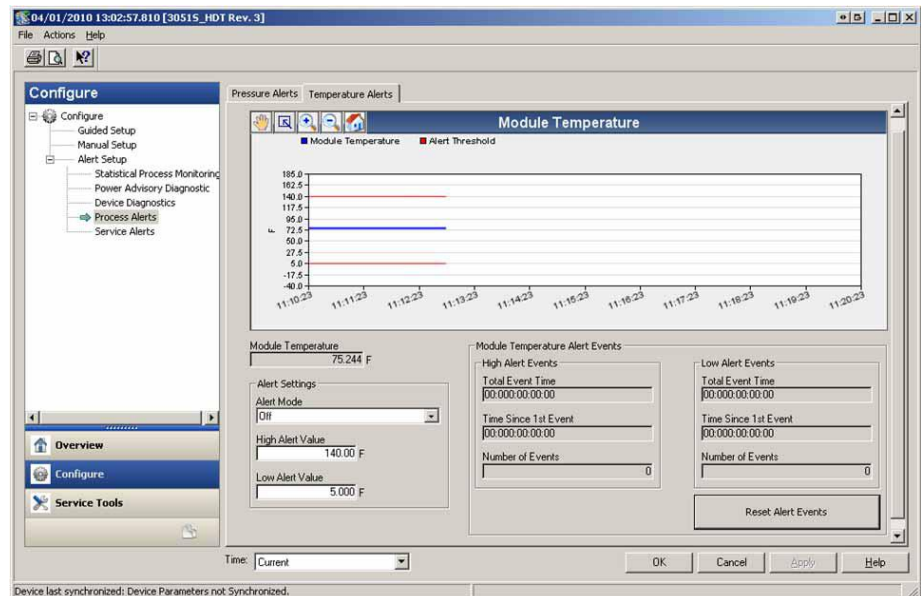

Figure 7-24 shows the configuration section for Temperature Alert. If ambient temperature goes above or below the alert values, the LCD will indicate a temperature alert and a HART alert will be generated by the transmitter. An active alert will not affect the transmitter’s 4 – 20 mA output signal.

Alert Mode

This setting dictates whether the diagnostic is On or Off. Selecting “On Unlatched” will generate a HART alert when the alert values are tripped. When temperature returns to normal and within the alert limits, the alert is automatically cleared. Selecting “On Latched” will generate the same HART alert but will require a manual reset to clear the alert.

Latched alert action is recommended if 3rd party alert monitor software is likely to miss alerts due to slow polling of HART data.

High Alert Value / Low Alert Value

These are independent trip values for the diagnostic. These values are represented on the graph by the red lines.

Total Event Time (High / Low)

These fields show the total time the transmitter's module temperature was above the High Alert Value or below the Low Alert Value.

Time Since 1st Event (High / Low)

This is the elapsed time since the first Temperature Alert event for High Alert Value and Low Alert Value. Subsequent events will increment the Total Event Time values but this value will remain unchanged.

Number of Events (High / Low)

This is the number of times the transmitter's module temperature was above the High Alert Value or below the Low Alert Value.

Reset Alert Events

Selecting this will reset all time stamp values and number of events to zero.

SERVICE ALERTS

Device Dashboard Fast Keys	2, 3, 5
-------------------------------	---------

Overview

Service Alert can be used to generate a time-based HART alert with customizable message. This can be used to remind personnel when to perform maintenance on the transmitter. When the alert is generated, the LCD will indicate "TIMER ALERT" and a HART alert will be generated by the transmitter. An active alert will not affect the transmitter's 4 – 20 mA output signal.

Figure 7-25. Service Alert screen

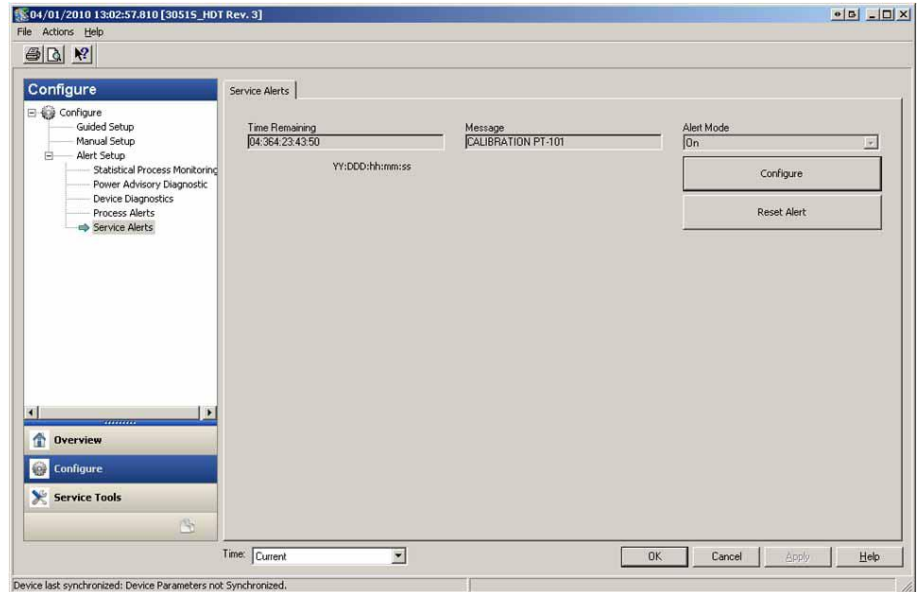

Time Remaining

Amount of time remaining before the HART alert is generated. This value begins counting down to zero as soon as the diagnostic is turned on. Time Remaining can be configured in terms of number of Years, Days, and Hours.

If transmitter loses power, Time Remaining will not continue to count down. Once powered up again, the timer resumes operation.

Message

User customizable message associated to the Service Alert. The message field can contain up to 32 alphanumeric characters and is stored in the non-volatile memory of the transmitter.

Alert Mode

This indicates whether the diagnostic is turned On or Off.

Configure

This method controls the Alert Mode of the diagnostic and allows for configuration of timer and message.

Reset Alert

Selecting this will reset the Time Remaining value and start the count down process again.

DEVICE DIAGNOSTICS

Overview

In addition to standard device diagnostics that provide notification of when the transmitter fails, the 3051S HART Diagnostic transmitter has predictive device diagnostics that detect issues in the electronics that may result in on-scale failure.

Figure 7-26. Device Diagnostics screen

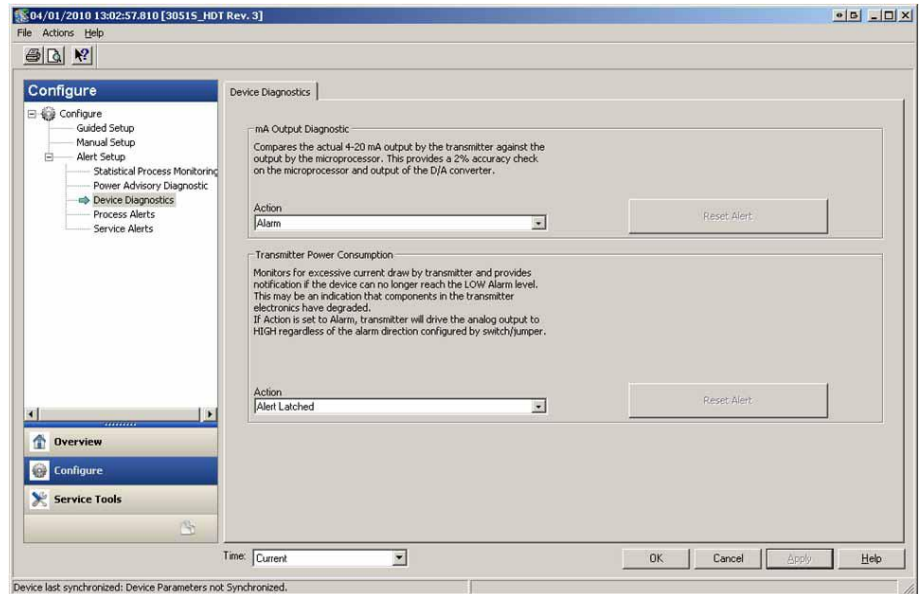

mA Output Diagnostic

The mA Output Diagnostic measures the actual 4 – 20 mA output from the transmitter’s Digital-to-Analog converter and compares it against the output by the transmitter’s microprocessor. If the measured value deviates from the expected value by 2% or more, the diagnostic will generate an alarm or alert.

NOTE

The default trip action for mA Output Diagnostic is set to Alarm. For use in SIS, the trip action must not be changed or the proper safety coverage stated on the FMEDA will not be realized.

Transmitter Power Consumption

Transmitter Power Consumption diagnostic monitors for excessive current draw by the transmitter. This diagnostic is used to detect a potential on-scale failure due to current leakage or failing electronics.

NOTE

If trip action is set to Alarm, the transmitter will drive the 4 – 20 mA output to fail HIGH regardless of the alarm direction configured by the alarm switch.

SMART WIRELESS THUM ADAPTER CONFIGURATION

Overview

Many older legacy control systems that only use analog can not take full advantage of HART diagnostics or additional process variables. The Smart Wireless THUM Adapter can transmit up to four process variables and additional HART status information at the user configurable update rate. The selectable process variables are Pressure, Module Temperature, Scaled Variable, Standard Deviation, Mean, and Coefficient of Variation.

Rosemount 3051S Series

Installation and Commissioning

Below are the four major steps to commission the 3051S HART Diagnostics transmitter and THUM. Further detail on these steps can be found in the Smart Wireless THUM Adapter instruction manual (p/n 00809-0100-4075).

1. Check the 3051S variable assignments (2nd, 3rd, and 4th variable) and remap as necessary to assign variables intended for use with the THUM.
2. Configure the Network ID and Join Key in order for the THUM to join wireless network.
3. Configure Update Rate for the THUM. This is frequency at which HART data is taken and transmitted over the wireless network.
4. Connect the 3051S to the THUM, as shown in Figure 7-27 on page 7-34, and make sure there is at least 250 Ohms resistance in the loop.

Figure 7-27. Wiring Diagram for 2-Wire Device

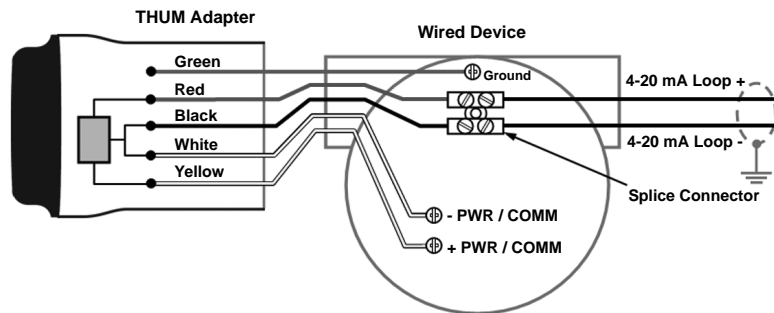

NOTE

The Smart Wireless THUM Adapter has a minimum update rate of 8 seconds and may not capture alerts that appeared in between updates. It is recommended to set diagnostic trip action to "Alert Latched" to minimize chance of missed alerts in between updates.

NOTE

When using Power Advisory Diagnostic and the THUM to detect changes on the electrical loop, a re-characterization of the loop must be performed when the THUM is installed for the first time.

ROSEMOUNT 333 HART TRI-LOOP CONFIGURATION

Overview

The Rosemount 333 HART Tri-Loop can be used in conjunction with the Rosemount 3051S with Advanced HART Diagnostics to acquire up to three more variables via 4-20mA analog signals. The additional three outputs are selected by the user and can include: Pressure, Temperature, Scaled Variable, Standard Deviation, Mean, or Coefficient of Variation.

Installation and Commissioning

Below are the four major steps to commission the 3051S and Tri-Loop. Further detail on these steps can be found in the Tri-Loop Instruction manual (document number 00809-0100-4757).

1. Check the 3051S variable mapping and remap as necessary to assign the three variables intended to be the Tri-Loop output. Take note of the variable information including variable, variable name, and variable units as it will be necessary to duplicate this exactly in the Tri-Loop for proper operation. Some useful variables for process diagnostics include Standard Deviation, Mean, Coefficient of Variation, and Sensor Temperature.

NOTE

The measured pressure will continue to be reported as a 4 – 20 mA value via the primary variable output.

2. Connect the 3051S to the 333 Tri-Loop. The 3051S 4-20mA output connects to the 333 Burst Input. See Figure 7-28.

Figure 7-28. 333 Tri-Loop Wiring Diagram

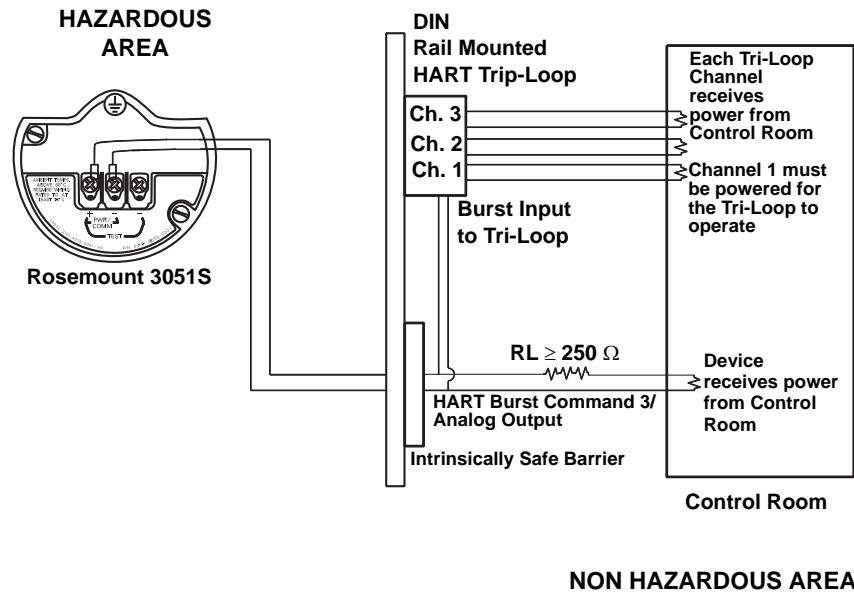

3. Configure the Tri-Loop. The Channel configuration must be identical to the variables mapped in the 3051S. **Note:** The Tri Loop default address is 1. The HART host must be configured to Poll for the 333 in order to find the Tri-Loop.
4. Enable Burst mode in the 3051S. The Burst Mode must be ON and the Burst Option must be set to Process Vars/Crnt.

Rosemount 3051S Series

SAFETY INSTRUMENTED SYSTEMS (SIS) CERTIFICATION

The safety-critical output of the 3051S with Advanced HART Diagnostic is provided through a two-wire, 4 - 20 mA signal representing pressure. The 3051S safety certified pressure transmitter is certified to: Low Demand; Type B.
SIL 2 for random integrity @ HFT=0
SIL 3 for random integrity @ HFT=1
SIL 3 for systematic integrity

3051S Safety Certified Identification

All 3051S transmitters must be identified as safety certified before installing into SIS systems.

NOTE

There are three versions of safety certified 3051S pressure transmitters. For transmitters with a yellow SIS circuit board installed (Output code B), please refer to Manual Supplement 00809-0700-4801. For transmitters without the Advanced HART Diagnostics circuit board installed, please refer to Section 6: Safety Instrumented Systems.

To identify a safety certified 3051S with Advanced HART Diagnostics:

1. Connect a HART host to the transmitter.
2. Check transmitter Revision numbers to verify that Electronics SW rev is 10 or higher and Sensor SW rev is 5 or higher.

Fast Key Sequence - 1, 3, 5, 3

Revision Numbers	
Field Device	3
Electronics Software	10 or higher
Electronics Hardware	1
Sensor Software	5 or higher

3. Verify that option code DA2 is included in the transmitter model code.

3051S SIS Installation

No special installation is required in addition to the standard installation practices outlined in this document. Always ensure a proper seal by installing the electronics housing cover(s).

Environmental limits are available in the 3051S Product Data Sheet (document number 00813-0100-4801). This document can be found at

<http://www2.emersonprocess.com/en-US/brands/rosemount/Documentation-and-Drawings/Product-Data-Sheets/Pages/index.aspx>

The loop should be designed so the terminal voltage does not drop below 12.0 Vdc when the transmitter output is 23.0 mA.

Security switch should be in the "ON" position during normal operation. See Figure 7-30 on page 7-38.

3051S SIS Commissioning

Use any HART-compliant master to communicate with and verify configuration of the 3051S Safety Certified transmitter with Advanced HART Diagnostics.

Rosemount 3051S Series

Configuring Alarm and Saturation Levels

1. If using a Field Communicator, use the following fast key sequence to set the Alarm and Saturation values.
Fast Key Sequence - 2, 2, 2, 5, 6
2. Manually set the direction for the Alarm to HI or LO using the ALARM switch as shown in Figure 7-30.

Figure 7-30. Security and alarm configuration

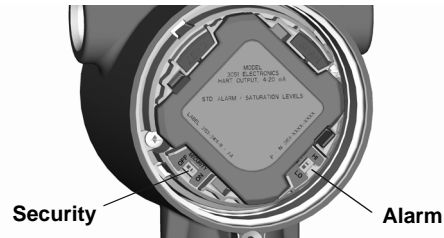

3051S SIS Operation and Maintenance

Proof Test

The following proof tests are recommended.

Proof test results and corrective actions taken must be documented at http://rosemount.d1asia.ph/rosemount/safety/ReportAFailure_newweb.asp (to report a failure) in the event that an error is found in the safety functionality. All proof test procedures must be carried out by qualified personnel.

Use “Fast Key Sequence” on page 3-6 to perform a Loop Test, Analog Output Trim, or Sensor Trim. Security switch should be in the “OFF” position during proof test execution and repositioned in the “ON” position after execution.

Simple Proof Test

The simple suggested proof test consists of a power cycle plus reasonability checks of the transmitter output. This test will detect ~ 41% of possible DU failures in the device.

Required tools: Field Communicator and mA meter.

1. Bypass the safety function and take appropriate action to avoid a false trip.
2. Use HART communication to set the transmitter in fixed current mode. For the Emerson Field Communicator, enter Fast Key Sequence 3, 5, 1. Select “4 Other.”
3. Enter the milliamp value representing a high alarm state.
4. Check the reference meter to verify the mA output corresponds to the entered value.
5. Enter the milliamp value representing a low alarm state.
6. Check the reference meter to verify the mA output corresponds to the entered value.
7. Remove the bypass and otherwise restore normal operation.
8. Document the test results per your requirements.
9. Place the Security switch in the “ON” position.

Comprehensive Proof Test

The comprehensive proof test consists of performing the same steps as the simple suggested proof test but with a two point calibration of the pressure sensor in place of the reasonability check. This test will detect ~ 87% of possible DU failures in the device.

Required tools: Field Communicator and pressure calibration equipment.

1. Bypass the safety function and take appropriate action to avoid a false trip.
2. Perform Proof Test 1.
3. Perform a minimum two point sensor calibration check using the 4-20 mA range points as the calibration points.
4. Check the reference mA meter to verify the mA output corresponds to the pressure input value.
5. If necessary, use "Choosing a Trim Procedure" on page 4-5 of the 3051S Reference Manual.
6. Document the test results per your requirements.
7. Remove the bypass and otherwise restore normal operation.
8. Place the Security switch in the "ON" position.

NOTE

The user determines the proof test requirements for impulse piping.

Inspection

Visual Inspection

Not required

Special Tools

Not required

Product Repair

The 3051S is repairable by major component replacement.

All failures detected by the transmitter diagnostics or by the proof-test must be reported. Feedback can be submitted electronically at http://rosemount.d1asia.ph/rosemount/safety/ReportAFailure_newweb.asp

All product repair and part replacement should be performed by qualified personnel.

3051S SIS Specifications

The 3051S must be operated in accordance to the functional and performance specifications provided in the 3051S Product Data Sheet (document number 00813-0100-4801).

Failure Rate Data

The FMEDA report includes failure rates and common cause Beta factor estimates.

The report is available at

<http://www2.emersonprocess.com/en-US/brands/rosemount/Safety-Products/Pages/index.aspx>.

Rosemount 3051S Series

Failure Values

Safety accuracy: 2.0%⁽¹⁾

Transmitter response time: 145 ms

Diagnostic response time: 1.5 seconds

Self-diagnostics Test: At least once every 30 minutes

(1) A 2% variation of the transmitter mA output is allowed before a safety trip. Trip values in the DCS or safety logic solver should be derated by 2%.

Product Life

50 years - based on worst case component wear-out mechanisms - not based on wear-out of process wetted materials

Report any safety related product information at:

http://rosemount.d1asia.ph/rosemount/safety/ReportAFailure_newweb.asp

OTHER INFORMATION

Digital Trim with Non-DD Based Communicators

The 3051S Pressure Transmitter with Advanced Diagnostics makes use of its Device Description to support an enhanced digital trim function. Use of a non-DD based host or communicator may require repeat trims to achieve maximum accuracy.

Temperature Rating

WARNING

Temperature rating for the Advanced HART Diagnostic electronics (p/n 03151-9071-000X) is T4. When upgrading a 3051S, the SuperModule and electronics must have equivalent approval labeling in order to maintain hazardous location approvals.

FIELD COMMUNICATOR MENU TREES

Figure 7-31. Overview Menu Tree

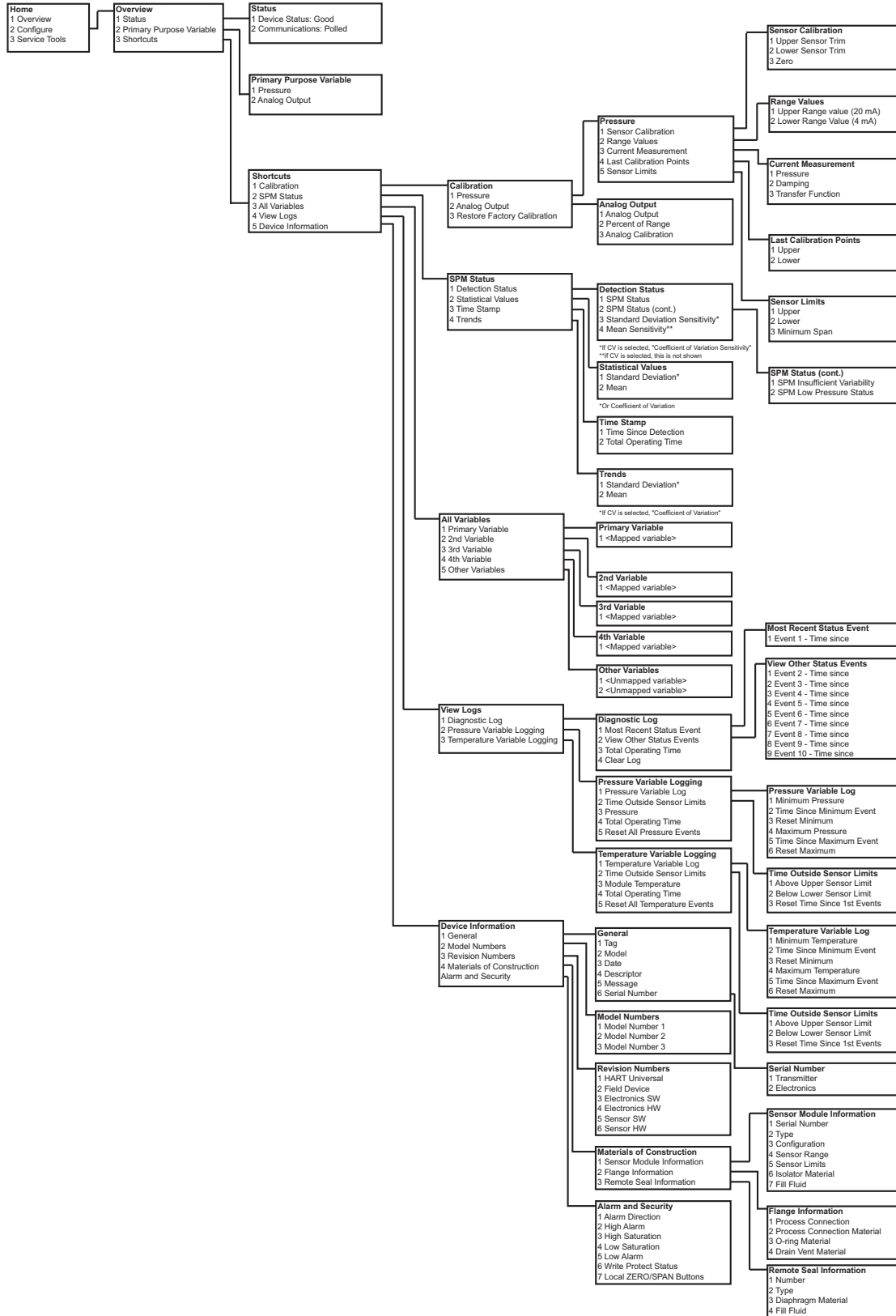

Rosemount 3051S Series

Figure 7-32. Configure (Guided Setup and Manual Setup) Menu Tree

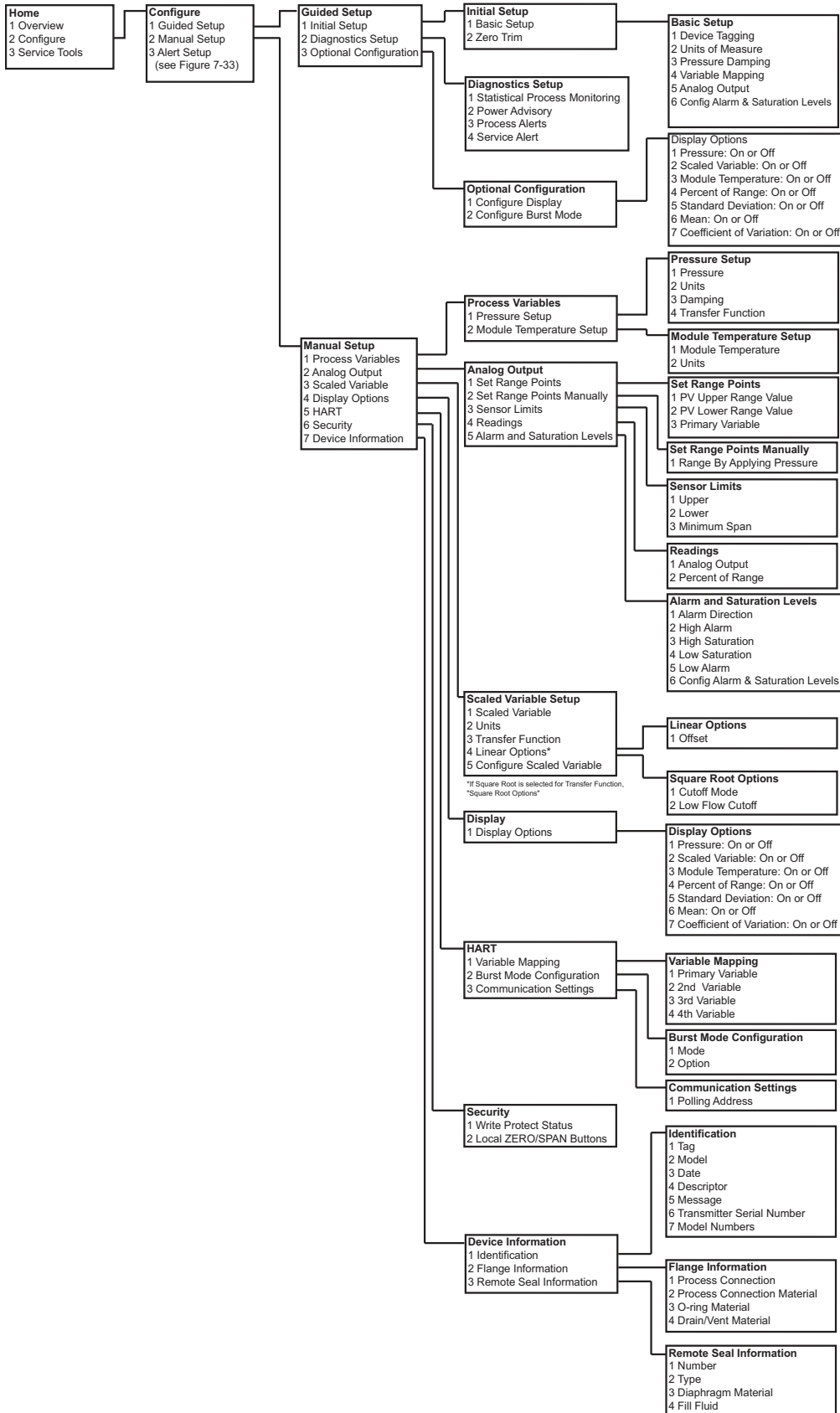
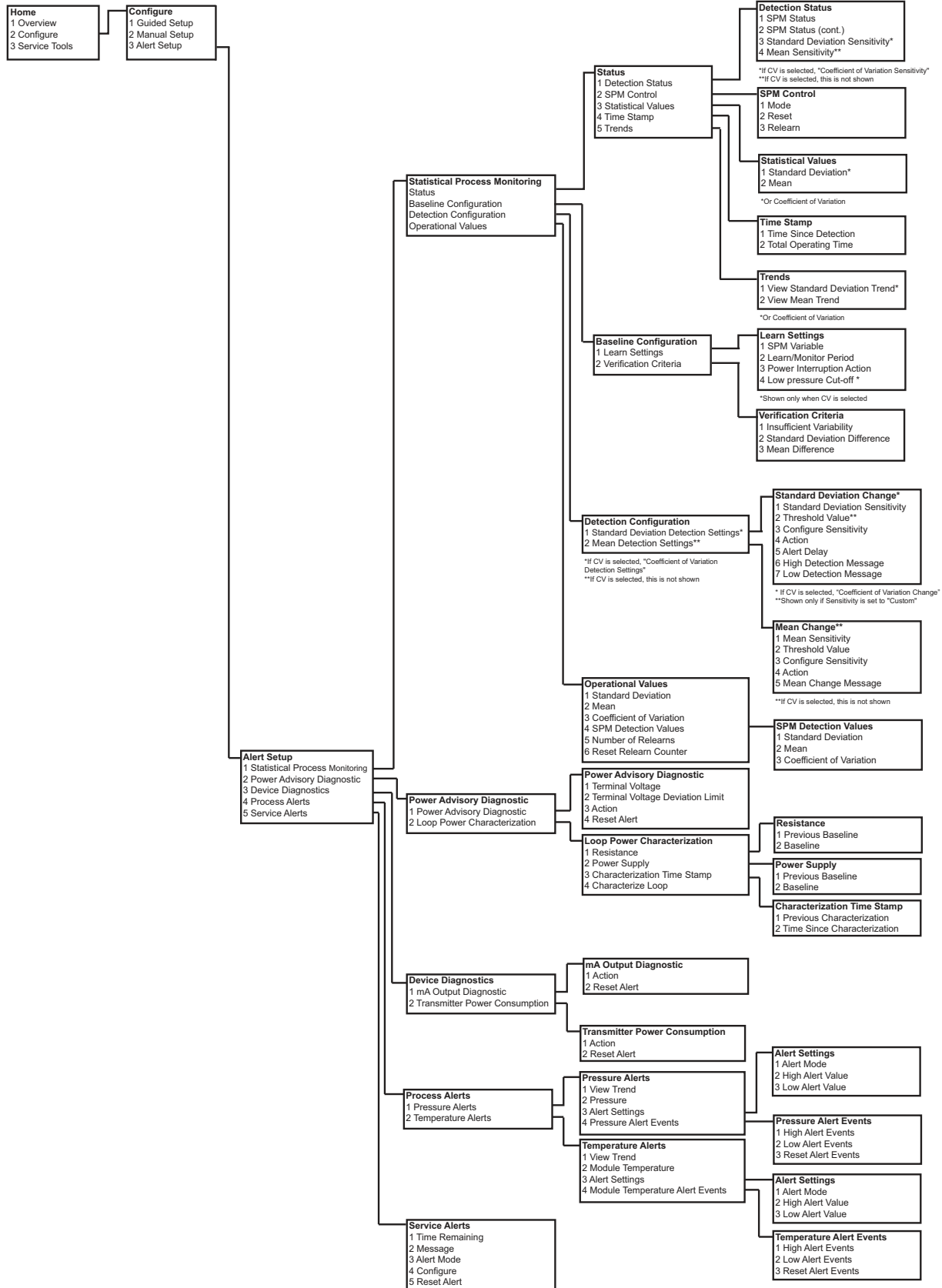
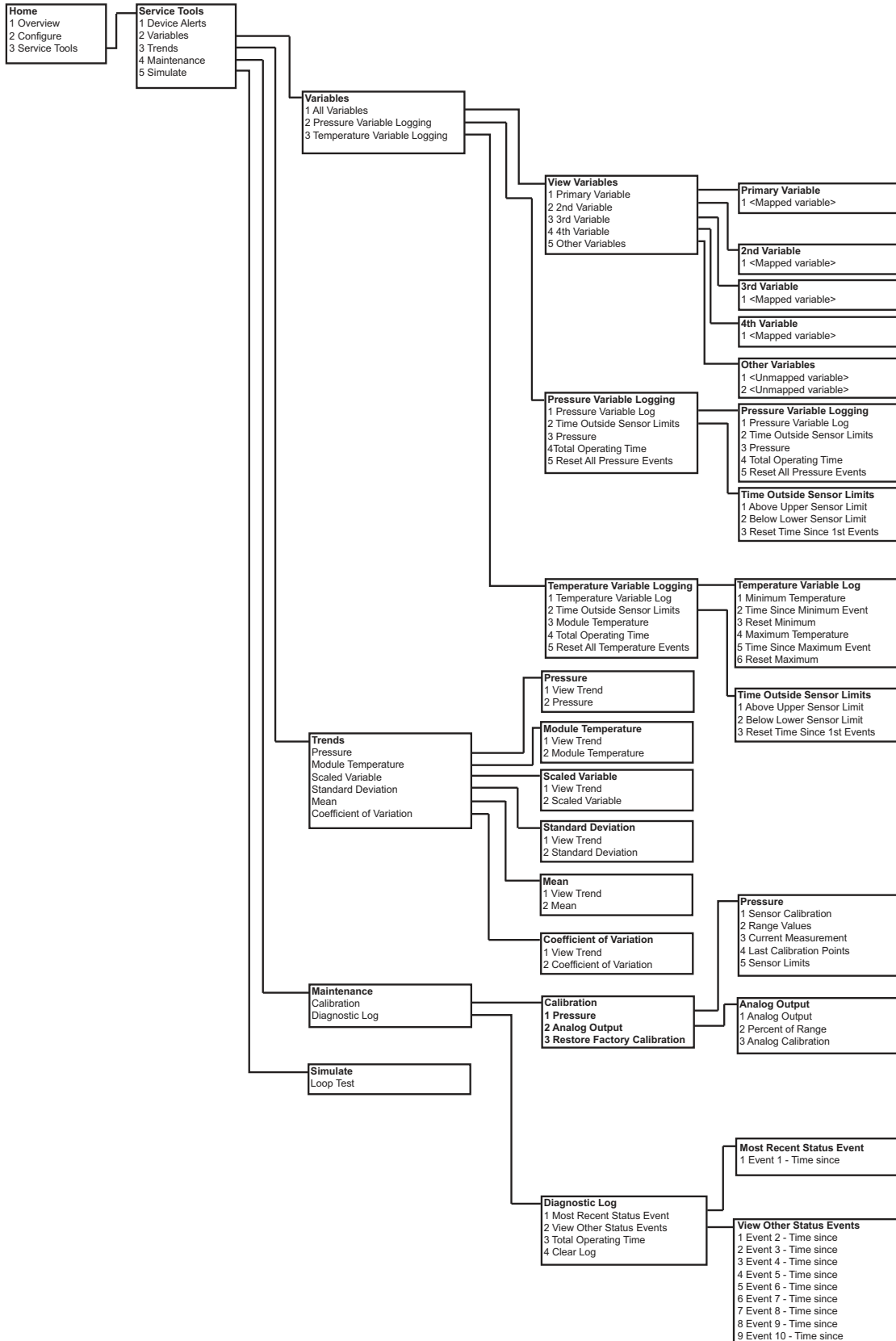

Figure 7-33. Configure (Alert Setup) Menu Tree



Rosemount 3051S Series

Figure 7-34. Service Tools Menu Tree



Appendix A Specifications and Reference Data

Performance Specifications	page A-1
Functional Specifications	page A-6
Physical Specifications	page A-12
Dimensional Drawings	page A-16
Ordering Information	page A-23
Exploded View Diagram	page A-41
Spare Parts	page A-42

PERFORMANCE SPECIFICATIONS

For zero-based spans, reference conditions, silicone oil fill, glass-filled PTFE o-rings, SST materials, Coplanar flange (3051S_C) or 1/2 in.- 14 NPT (3051S_T) process connections, digital trim values set to equal range points.

Conformance to Specification ($\pm 3\sigma$ (Sigma))

Technology leadership, advanced manufacturing techniques, and statistical process control ensure measurement specification conformance to $\pm 3\sigma$ or better.

Reference Accuracy

Stated reference accuracy equations include terminal based linearity, hysteresis, and repeatability.

Transmitter with Coplanar Sensor Module (Single Variable)

Differential Pressure (3051S_CD) Gage Pressure (3051S_CG)			
	Ultra	Classic	Ultra for Flow ⁽¹⁾
Ranges 2 - 4	$\pm 0.025\%$ of span; For spans less than 10:1, $\pm [0.005 + 0.0035(\text{URL} / \text{Span})]\%$ of span	$\pm 0.055\%$ of span; For spans less than 10:1, $\pm [0.015 + 0.005(\text{URL} / \text{Span})]\%$ of span	$\pm 0.04\%$ of reading up to 8:1 DP turndown from URL; $\pm [0.04 + 0.0023(\text{URL} / \text{Reading})]\%$ of reading to 200:1 DP turndown from URL
Range 5	$\pm 0.05\%$ of span; For spans less than 10:1, $\pm [0.005 + 0.0045(\text{URL} / \text{Span})]\%$ of span	$\pm 0.065\%$ of span; For spans less than 10:1, $\pm [0.015 + 0.005(\text{URL} / \text{Span})]\%$ of span	Not Available
Range 1	$\pm 0.09\%$ of span; For spans less than 15:1, $\pm [0.015 + 0.005(\text{URL} / \text{Span})]\%$ of span	$\pm 0.10\%$ of span; For spans less than 15:1, $\pm [0.025 + 0.005(\text{URL} / \text{Span})]\%$ of span	Not Available
Range 0	$\pm 0.09\%$ of span; For spans less than 2:1, $\pm 0.045\%$ of URL	$\pm 0.10\%$ of span; For spans less than 2:1, $\pm 0.05\%$ of URL	Not Available
Absolute Pressure (3051S_CA)			
	Ultra	Classic	
Ranges 1 - 4	$\pm 0.025\%$ of span; For spans less than 10:1, $\pm [0.004(\text{URL} / \text{Span})]\%$ of span	$\pm 0.055\%$ of span; For spans less than 10:1, $\pm [0.0065(\text{URL} / \text{Span})]\%$ of span	
Range 0	$\pm 0.075\%$ of span; For spans less than 5:1, $\pm [0.025 + 0.01(\text{URL} / \text{Span})]\%$ of span	$\pm 0.075\%$ of span; For spans less than 5:1, $\pm [0.025 + 0.01(\text{URL} / \text{Span})]\%$ of span	

(1) Ultra for Flow is only available for 3051S_CD ranges 2-3. For calibrated spans from 1:1 to 2:1 of URL, add $\pm 0.005\%$ of span analog output error.

Rosemount 3051S Series

Transmitter with In-Line Sensor Module

Absolute Pressure (3051S_TA) Gage Pressure (3051S_TG)		
	Ultra	Classic
Ranges 1 - 4	±0.025% of span For spans less than 10:1, ±[0.004(URL / Span)]% of span	±0.055% of span For spans less than 10:1, ±[0.0065(URL / Span)]% of span
Range 5	±0.04% of span	±0.065% of span

Liquid Level Transmitter

3051S_L		
	Ultra	Classic
	±0.065% of span For spans less than 10:1, ±[0.015 + 0.005(URL / Span)]% of span	±0.065% of span For spans less than 10:1, ±[0.015 + 0.005(URL / Span)]% of span

Transmitter Total Performance

Total performance is based on combined errors of reference accuracy, ambient temperature effect, and line pressure effect.

Models	Ultra	Classic	Ultra for Flow ⁽¹⁾
3051S_CD	±0.1% of span; for ±50°F (28°C) temperature changes; 0-100% relative humidity, up to 740 psi (51 bar) line pressure (DP only), from 1:1 to 5:1 rangedown	±0.15% of span; for ±50°F (28°C) temperature changes; 0-100% relative humidity, up to 740 psi (51 bar) line pressure (DP only), from 1:1 to 5:1 rangedown	±0.1% of reading; for ±50°F (28°C) temperature changes; 0-100% relative humidity, up to 740 psi (51 bar) line pressure, over 8:1 DP turndown from URL
3051S_CG			
3051S_CA			
3051S_T			
3051S_L	Use <i>Instrument Toolkit</i> or the <i>QZ Option</i> to quantify the total performance of a remote seal assembly under operating conditions.		

(1) Ultra for Flow is only available for 3051S_CD Ranges 2-3.

Long Term Stability

Models	Ultra and Ultra for Flow ⁽¹⁾	Classic
3051S_CD	±0.20% of URL for 10 years; for ±50°F (28°C) temperature changes, up to 1000 psi (68,9 bar) line pressure	±0.125% of URL for 5 years; for ±50°F (28°C) temperature changes, up to 1000 psi (68,9 bar) line pressure
3051S_CG		
3051S_CA		
3051S_T		

(1) Ultra for Flow is only available on 3051S_CD ranges 2-3.

Warranty⁽¹⁾

Models	Ultra and Ultra for Flow	Classic
All 3051S Products	12-year limited warranty ⁽²⁾	1-year limited warranty ⁽³⁾

- (1) Warranty details can be found in Emerson Process Management Terms & Conditions of Sale, Document 63445, Rev G (10/06).
- (2) Rosemount Ultra and Ultra for Flow transmitters have a limited warranty of twelve (12) years from date of shipment. All other provisions of Emerson Process Management standard limited warranty remain the same.
- (3) Goods are warranted for twelve (12) months from the date of initial installation or eighteen (18) months from the date of shipment by seller, whichever period expires first.

Dynamic Performance

Total Time Response at 75 °F (24 °C), includes dead time⁽¹⁾

3051S_C, 3051S_L	3051S_T
DP Ranges 2-5: 100 ms Range 1: 255 ms Range 0: 700 ms	100 ms

(1) For option code DA2, add 45 ms (nominal) to stated values.

Dead Time⁽¹⁾

3051S_C, 3051S_T, 3051S_L
45 ms (nominal)

(1) For option code DA2, dead time is 90 milliseconds (nominal).

Update Rate

3051S_C or T 3051S_L
22 updates per sec.

Rosemount 3051S Series

Ambient Temperature Effect

Transmitter with Coplanar Sensor Module (Single Variable)

Differential Pressure: (3051S_CD) Gage Pressure: (3051S_CG)			
	Ultra per 50 °F (28 °C)	Classic per 50 °F (28 °C)	Ultra for Flow⁽¹⁾ -40 to 185 °F (-40 to 85 °C)
Ranges 2 - 5 ⁽²⁾	±(0.009% URL + 0.025% span) from 1:1 to 10:1; ±(0.018% URL + 0.08% span) from >10:1 to 200:1	±(0.0125% URL + 0.0625% span) from 1:1 to 5:1; ±(0.025% URL + 0.125% span) from >5:1 to 100:1	±0.13% of reading up to 8:1 DP turndown from URL; ±[0.13 + 0.0187(URL/Reading)]% of reading to 100:1 DP turndown from URL
Range 0	±(0.25% URL + 0.05% span) from 1:1 to 30:1	±(0.25% URL + 0.05% span) from 1:1 to 30:1	Not Available
Range 1	±(0.1% URL + 0.25% span) from 1:1 to 50:1	±(0.1% URL + 0.25% span) from 1:1 to 50:1	Not Available
Absolute Pressure: (3051S_CA)			
	Ultra per 50 °F (28 °C)	Classic per 50 °F (28 °C)	
Ranges 2-4	±(0.0125% URL + 0.0625% span) from 1:1 to 5:1; ±(0.025% URL + 0.125% span) from >5:1 to 200:1	±(0.0125% URL + 0.0625% span) from 1:1 to 5:1; ±(0.025% URL + 0.125% span) from >5:1 to 100:1	
Range 0	±(0.1% URL + 0.25% span) from 1:1 to 30:1	±(0.1% URL + 0.25% span) from 1:1 to 30:1	
Range 1	±(0.0125% URL + 0.0625% span) from 1:1 to 5:1; ±(0.025% URL + 0.125% span) from >5:1 to 100:1	±(0.0125% URL + 0.0625% span) from 1:1 to 5:1; ±(0.025% URL + 0.125% span) from >5:1 to 100:1	

- (1) Ultra for Flow is only available for 3051S_CD Ranges 2-3.
(2) Use Classic specification for 3051S_CD Range 5 Ultra.

Transmitter with In-Line Sensor Module

Absolute Pressure: (3051S_TA) Gage Pressure: (3051S_TG)			
	Ultra per 50 °F (28 °C)	Classic per 50 °F (28 °C)	
Ranges 2-4	±(0.009% URL + 0.025% span) from 1:1 to 10:1; ±(0.018% URL + 0.08% span) from >10:1 to 100:1	±(0.0125% URL + 0.0625% span) from 1:1 to 5:1; ±(0.025% URL + 0.125% span) from >5:1 to 100:1	
Range 5	±(0.05% URL + 0.075% span) from 1:1 to 10:1	±(0.05% URL + 0.075% span) from 1:1 to 10:1	
Range 1	±(0.0125% URL + 0.0625% span) from 1:1 to 5:1; ±(0.025% URL + 0.125% span) from >5:1 to 100:1	±(0.0125% URL + 0.0625% span) from 1:1 to 5:1; ±(0.025% URL + 0.125% span) from >5:1 to 100:1	

Liquid Level Transmitter

3051S_L			
		Ultra	Classic
		See <i>Instrument Toolkit</i>	See <i>Instrument Toolkit</i>

Line Pressure Effect⁽¹⁾

3051S_CD	Ultra and Ultra for Flow	Classic
Zero Error⁽²⁾		
Range 2-3	± 0.025% URL per 1000 psi (69 bar)	± 0.05% URL per 1000 psi (69 bar)
Range 0	± 0.125% URL per 100 psi (6,9 bar)	± 0.125% URL per 100 psi (6,9 bar)
Range 1	± 0.25% URL per 1000 psi (69 bar)	± 0.25% URL per 1000 psi (69 bar)
Span Error⁽³⁾		
Range 2-3	± 0.1% of reading per 1000 psi (69 bar)	± 0.1% of reading per 1000 psi (69 bar)
Range 0	± 0.15% of reading per 100 psi (6,9 bar)	± 0.15% of reading per 100 psi (6,9 bar)
Range 1	± 0.4% of reading per 1000 psi (69 bar)	± 0.4% of reading per 1000 psi (69 bar)

(1) For zero error specifications for line pressures above 2000 psi (137,9 bar) or line pressure effect specifications for DP Ranges 4-5, see the 3051S Reference Manual (document number 00809-0100-4801).

(2) Zero error can be removed by performing a zero trim at line pressure.

(3) Specifications for option code P0 are 2 times those shown above.

Mounting Position Effects

Models	Ultra, Ultra for Flow, and Classic
3051S_CD or CG	Zero shifts up to ±1.25 inH ₂ O (3,11 mbar), which can be zeroed Span: no effect
3051S_CA 3051S_T	Zero shifts to ±2.5 inH ₂ O (6,22 mbar), which can be zeroed Span: no effect
3051S_L	With liquid level diaphragm in vertical plane, zero shift of up to ±1 inH ₂ O (2,5 mbar). With diaphragm in vertical plane, zero shift of up to ±5 inH ₂ O (12,5 mbar) plus extension length on extended units. All zero shifts can be zeroed. Span: no effect

Vibration Effect

Less than ±0.1% of URL when tested per the requirements of IEC60770-1 field or pipeline with high vibration level (10-60 Hz 0.21mm displacement peak amplitude / 60-2000 Hz 3g).

For Housing Style codes 1J, 1K, 1L, 2J, and 2M:

Less than ±0.1% of URL when tested per the requirements of IEC60770-1 field with general application or pipeline with low vibration level (10-60 Hz 0.15mm displacement peak amplitude / 60-500 Hz 2g).

Power Supply Effect

Less than ±0.005% of calibrated span per volt change in voltage at the transmitter terminals

Electromagnetic Compatibility (EMC)

Meets all relevant requirements of EN 61326 and NAMUR NE-21.⁽¹⁾

(1) NAMUR NE-21 does not apply to wireless output code X.

Transient Protection (Option T1)

Tested in accordance with IEEE C62.41.2-2002, Location Category B

- 6 kV crest (0.5 μs - 100 kHz)
- 3 kA crest (8 × 20 microseconds)
- 6 kV crest (1.2 × 50 microseconds)

Rosemount 3051S Series

FUNCTIONAL SPECIFICATIONS

Range and Sensor Limits

Transmitter with Coplanar Sensor Module (Single Variable)

Range	DP Sensor (3051S_CD, 3051S_LD)		GP Sensor (3051S_CG, 3051S_LG)		AP Sensor ⁽¹⁾ (3051S_CA, 3051S_LA)	
	Lower (LRL) ⁽²⁾	Upper (URL)	Lower (LRL) ⁽³⁾	Upper (URL)	Lower (LRL)	Upper (URL)
0	-3 inH ₂ O (-7,5 mbar)	3 inH ₂ O (7,5 mbar)	N/A	N/A	0 psia (0 bar)	5 psia (0,34 bar)
1	-25 inH ₂ O (-62,3 mbar)	25 inH ₂ O (62,3 mbar)	-25 inH ₂ O (-62,3 mbar)	25 inH ₂ O (62,3 mbar)	0 psia (0 bar)	30 psia (2,07 bar)
2	-250 inH ₂ O (-0,62 bar)	250 inH ₂ O (0,62 bar)	-250 inH ₂ O (-0,62 bar)	250 inH ₂ O (0,62 bar)	0 psia (0 bar)	150 psia (10,34 bar)
3	-1000 inH ₂ O (-2,49 bar)	1000 inH ₂ O (2,49 bar)	-393 inH ₂ O (-979 mbar)	1000 inH ₂ O (2,49 bar)	0 psia (0 bar)	800 psia (55,16 bar)
4	-300 psi (-20,7 bar)	300 psi (20,7 bar)	-14.2 psig (-979 mbar)	300 psi (20,7 bar)	0 psia (0 bar)	4000 psia (275,8 bar)
5	-2000 psi (-137,9 bar)	2000 psi (137,9 bar)	-14.2 psig (-979 mbar)	2000 psi (137,9 bar)	N/A	N/A

- (1) Range 0 is not available for 3051S_LA.
(2) The Lower Range Limit (LRL) is 0 inH₂O (0 mbar) for Ultra for Flow performance class.
(3) Assumes atmospheric pressure of 14.7 psig (1 bar).

Transmitter with In-Line Sensor Module

Range	GP Sensor (3051S_TG)		AP Sensor (3051S_TA)	
	Lower (LRL) ⁽¹⁾	Upper (URL)	Lower (LRL)	Upper (URL)
1	-14.7 psig (-1,01 bar)	30 psig (2,07 bar)	0 psia (0 bar)	30 psia (2,07 bar)
2	-14.7 psig (-1,01 bar)	150 psig (10,34 bar)	0 psia (0 bar)	150 psia (10,34 bar)
3	-14.7 psig (-1,01 bar)	800 psig (55,16 bar)	0 psia (0 bar)	800 psia (55,16 bar)
4	-14.7 psig (-1,01 bar)	4000 psig (275,8 bar)	0 psia (0 bar)	4000 psia (275,8 bar)
5	-14.7 psig (-1,01 bar)	10000 psig (689,5 bar)	0 psia (0 bar)	10000 psia (689,5 bar)

- (1) Assumes atmospheric pressure of 14.7 psig (1 bar).

Minimum Span Limits

Transmitter with Coplanar Sensor Module (Single Variable)

Range	DP Sensor (3051S_CD, 3051S_LD)		GP Sensor (3051S_CG, 3051S_LG)		AP Sensor (3051S_CA, 3051S_LA)	
	Ultra & Ultra for Flow	Classic	Ultra	Classic	Ultra	Classic
0	0.1 inH ₂ O (0,25 mbar)	0.1 inH ₂ O (0,25 mbar)	N/A	N/A	0.167 psia (11,5 mbar)	0.167 psia (11,5 mbar)
1	0.5 inH ₂ O (1,24 mbar)	0.5 inH ₂ O (1,24 mbar)	0.5 inH ₂ O (1,24 mbar)	0.5 inH ₂ O (1,24 mbar)	0.3 psia (20,7 mbar)	0.3 psia (20,7 mbar)
2	1.3 inH ₂ O (3,11 mbar)	2.5 inH ₂ O (6,23 mbar)	1.3 inH ₂ O (3,11 mbar)	2.5 inH ₂ O (6,23 mbar)	0.75 psia (51,7 mbar)	1.5 psia (103,4 mbar)
3	5.0 inH ₂ O (12,4 mbar)	10.0 inH ₂ O (24,9 mbar)	5.0 inH ₂ O (12,4 mbar)	10.0 inH ₂ O (24,9 mbar)	4 psia (275,8 mbar)	8 psia (0,55 bar)
4	1.5 psi (103,4 mbar)	3.0 psi (206,8 mbar)	1.5 psig (103,4 mbar)	3.0 psig (206,8 mbar)	20 psia (275,8 mbar)	40 psia (2,76 bar)
5	10.0 psi (689,5 mbar)	20.0 psi (1,38 bar)	10.0 psig (689,5 mbar)	20.0 psig (1,38 bar)	N/A	N/A

Transmitter with In-Line Sensor Module

Range	GP Sensor (3051S_TG)		AP Sensor (3051S_TA)	
	Ultra	Classic	Ultra	Classic
1	0.3 psig (20,7 mbar)	0.3 psig (20,7 mbar)	0.3 psia (20,7 mbar)	0.3 psia (20,7 mbar)
2	0.75 psig (51,7 mbar)	1.5 psig (103,4 bar)	0.75 psia (51,7 mbar)	1.5 psia (103,4 bar)
3	4 psig (275,8 mbar)	8 psig (0,55 bar)	4 psia (275,8 mbar)	8 psia (0,55 bar)
4	20 psig (1,58 bar)	40 psig (2,76 bar)	20 psia (1,58 bar)	40 psia (2,76 bar)
5	1000 psig (68,9 bar)	2000 psig (137,9 bar)	1000 psia (68,9 bar)	2000 psia (137,9 bar)

Service

Liquid, gas, and vapor applications

HART / 4–20 mA

Zero and Span Adjustment

Zero and span values can be set anywhere within the range.
Span must be greater than or equal to the minimum span.

Output

Two-wire 4–20 mA is user-selectable for linear or square root output. Digital process variable superimposed on 4–20 mA signal, available to any host that conforms to the HART protocol.

Power Supply

External power supply required.

- 3051S: 10.5 to 42.4 Vdc with no load
- 3051S with Advanced HART Diagnostics Suite: 12 to 42.4 Vdc with no load

Load Limitations

Maximum loop resistance is determined by the voltage level of the external power supply, as described by:

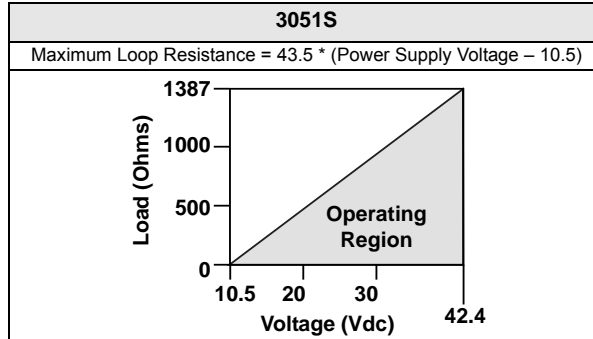

The Field Communicator requires a minimum loop resistance of 250Ω for communication.

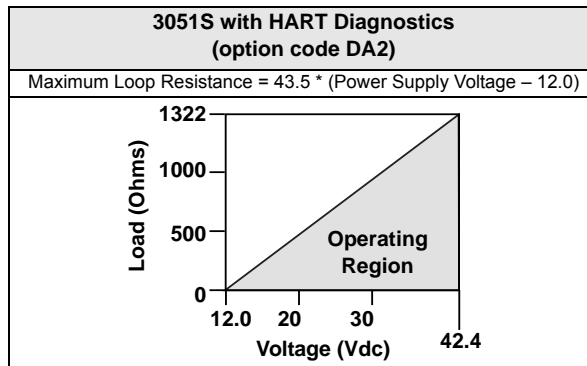

The Field Communicator requires a minimum loop resistance of 250Ω for communication.

Advanced HART Diagnostics Suite (Option Code DA2)

Statistical Process Monitoring (SPM) provides statistical data (standard deviation, mean, coefficient of variation) that can be used to detect process and process equipment anomalies, including plugged impulse lines, air entrainment, pump cavitation, furnace flame instability, distillation column flooding and more. This diagnostic allows you to take preventative measures before abnormal process situations result in unscheduled downtime or rework.

Power Advisory diagnostic proactively detects and notifies you of degraded electrical loop integrity before it can affect your process operation. Example loop problems that can be detected include water in the terminal compartment, corrosion of terminals, improper grounding, and unstable power supplies.

The enhanced EDDL Device Dashboard presents the diagnostics in a graphical, task-based interface that provides single click access to critical process/device information and descriptive graphical troubleshooting.

Suite includes: Statistical Process Monitoring (SPM), Power Advisory, Status Log, Variable Log, Advanced Process Alerts, Service Alerts, and Time Stamp capability.

Power Supply

External power supply required; transmitters operate on 9.0 to 32.0 Vdc transmitter terminal voltage.

Current Draw

17.5 mA for all configurations (including LCD display option)

Overpressure Limits

Transmitters withstand the following limits without damage:

Coplanar Sensor Module (Single Variable)

Range	DP ⁽¹⁾ & GP	AP
	3051S_CD, 3051S_CG	3051S_CA
0	750 psi (51,7 bar)	60 psia (4,13 bar)
1	2000 psi (137,9 bar)	750 psia (51,7 bar)
2	3626 psi (250,0 bar)	1500 psia (103,4 bar)
3	3626 psi (250,0 bar)	1600 psia (110,3 bar)
4	3626 psi (250,0 bar)	6000 psia (413,7 bar)
5	3626 psi (250,0 bar)	N/A

(1) The overpressure limit of a DP Sensor with the P9 option is 4500 psig (310,3 bar). The overpressure limit of a DP Sensor with the P0 option is 6092 psig (420 bar).

In-Line Sensor Module

Range	GP	AP
	3051S_TG	3051S_TA
1	750 psi (51,7 bar)	
2	1500 psi (103,4 bar)	
3	1600 psi (110,3 bar)	
4	6000 psi (413,7 bar)	
5	15000 psi (1034,2 bar)	

Liquid Level Transmitter (3051S_L)

Overpressure limit is dependent on the flange rating or sensor rating (whichever is lower). Use *Instrument Toolkit* to ensure the seal system meets all pressure and temperature limits.

Static Pressure Limits

Coplanar Sensor Module (Single Variable)

Operates within specifications between static line pressures of:

Range	DP Sensor ⁽¹⁾
	3051S_CD
0	0.5 psia to 750 psig (0,03 to 51,71 bar)
1	0.5 psia to 2000 psig (0,03 to 137,9 bar)
2	0.5 psia to 3626 psig (0,03 to 250 bar)
3	0.5 psia to 3626 psig (0,03 to 250 bar)
4	0.5 psia to 3626 psig (0,03 to 250 bar)
5	0.5 psia to 3626 psig (0,03 to 250 bar)

(1) The static pressure limit of a DP Sensor with the P9 option is 4500 psig (310,3 bar). The static pressure limit of a DP Sensor with the P0 option is 6092 psig (420 bar).

Burst Pressure Limits

Coplanar Sensor Module (3051S_C)

10000 psig (689,5 bar)

In-Line Sensor Module (3051S_T)

- Ranges 1-4: 11000 psi (758,4 bar)
- Range 5: 26000 psi (1792,64 bar)

Rosemount 3051S Series

Temperature Limits

Ambient

-40 to 185 °F (-40 to 85 °C)
With LCD display⁽¹⁾: -40 to 175 °F (-40 to 80 °C)
With option code P0: -20 to 185 °F (-29 to 85 °C)

(1) LCD display may not be readable and LCD updates will be slower at temperatures below -4 °F (-20 °C).

Storage

-50 to 185 °F (-46 to 85 °C)
With LCD display: -40 to 185 °F (-40 to 85 °C)

Process Temperature Limits

At atmospheric pressures and above:

Coplanar Sensor Module (3051S_C)	
Silicone Fill Sensor ⁽¹⁾⁽²⁾	
with Coplanar Flange	-40 to 250 °F (-40 to 121 °C) ⁽³⁾
with Traditional Flange	-40 to 300 °F (-40 to 149 °C) ⁽³⁾⁽⁴⁾
with Level Flange	-40 to 300 °F (-40 to 149 °C) ⁽³⁾
with 305 Integral Manifold	-40 to 300 °F (-40 to 149 °C) ⁽³⁾⁽⁴⁾
Inert Fill Sensor ⁽¹⁾⁽⁵⁾	-40 to 185 °F (-40 to 85 °C) ⁽⁶⁾⁽⁷⁾
In-Line Sensor Module (3051S_T)	
Silicone Fill Sensor ⁽¹⁾	-40 to 250 °F (-40 to 121 °C) ⁽³⁾
Inert Fill Sensor ⁽¹⁾	-22 to 250 °F (-30 to 121 °C) ⁽³⁾
3051S_L Level Transmitter	
Syltherm® XLT	-102 to 293 °F (-75 to 145 °C)
Silicone 704 ⁽⁸⁾	32 to 401 °F (0 to 205 °C)
Silicone 200	-49 to 401 °F (-45 to 205 °C)
Inert (Halocarbon)	-49 to 320 °F (-45 to 160 °C)
Glycerin and Water	5 to 203 °F (-15 to 95 °C)
Neobee M-20 [®]	5 to 401 °F (-15 to 205 °C)
Propylene Glycol and Water	5 to 203 °F (-15 to 95 °C)

(1) Process temperatures above 185 °F (85 °C) require derating the ambient limits by a 1.5:1 ratio. For example, for process temperature of 195 °F (91 °C), new ambient temperature limit is equal to 170 °F (77 °C). This can be determined as follows:
 $(195\text{ °F} - 185\text{ °F}) \times 1.5 = 15\text{ °F}$
 $185\text{ °F} - 15\text{ °F} = 170\text{ °F}$

(2) 212 °F (100 °C) is the upper process temperature limit for DP Range 0.

(3) 220 °F (104 °C) limit in vacuum service; 130 °F (54 °C) for pressures below 0.5 psia.

(4) -20 °F (-29 °C) is the lower process temperature limit with option code P0.

(5) 32 °F (0 °C) is the lower process temperature limit for DP Range 0.

(6) For 3051S_C, 160 °F (71 °C) limit in vacuum service.

(7) Not available for 3051S_CA.

(8) Upper limit of 600 °F (315 °C) is available with 1199 seal assemblies mounted away from the transmitter with the use of capillaries and up to 500 °F (260 °C) with direct mount extension.

Humidity Limits

0–100% relative humidity

Turn-On Time

When power is applied to the transmitter during startup, performance will be within specifications per the time period described below:

Transmitter	Turn-On Time (Typical)
3051S, 3051S_L	2 seconds
Diagnostics	5 seconds

Volumetric Displacement

Less than 0.005 in³ (0,08 cm³)

Damping

Analog output response time to a step change is user-selectable from 0 to 60 seconds for one time constant. Software damping is in addition to sensor module response time.

Failure Mode Alarm

HART 4-20 mA (output option code A)

If self-diagnostics detect a gross transmitter failure, the analog signal will be driven offscale to alert the user. Rosemount standard (default), NAMUR, and custom alarm levels are available (see Alarm Configuration below).

High or low alarm signal is software-selectable or hardware-selectable via the optional switch (option D1).

Alarm Configuration

	High Alarm	Low Alarm
Default	≥ 21.75 mA	≤ 3.75 mA
NAMUR compliant ⁽¹⁾	≥ 22.5 mA	≤ 3.6 mA
Custom levels ^{(2) (3)}	20.2 - 23.0 mA	3.4 - 3.8 mA

- (1) Analog output levels are compliant with NAMUR recommendation NE 43, see option codes C4 or C5.
- (2) Low alarm must be 0.1 mA less than low saturation and high alarm must be 0.1 mA greater than high saturation.
- (3) For option code DA2, low alarm custom values are 3.6 - 3.8 mA.

Rosemount 3051S Series

PHYSICAL SPECIFICATIONS

Safety-Certified Transmitter Failure Values

Safety accuracy: 2.0%⁽¹⁾
Safety response time: 1.5 seconds

Electrical Connections

$\frac{1}{2}$ -14 NPT, G $\frac{1}{2}$, and M20 × 1.5 conduit. HART interface connections fixed to terminal block for Output code A and X.

Process Connections

Coplanar Sensor Module (3051S_C)	
Standard	$\frac{1}{4}$ -18 NPT on 2 $\frac{1}{8}$ -in. centers
Flange Adapters	$\frac{1}{2}$ -14 NPT and RC $\frac{1}{2}$ on 2-in. (50.8 mm), 2 $\frac{1}{8}$ -in. (54.0 mm), or 2 $\frac{1}{4}$ -in. (57.2 mm) centers
In-Line Sensor Module (3051S_T)	
Standard	$\frac{1}{2}$ -14 NPT Female
F11 Code	Non-threaded instrument flange (available in SST for sensor ranges 1-4 only)
G11 Code	G $\frac{1}{2}$ A DIN 16288 Male (available in SST for sensor ranges 1-4 only)
H11 Code	Autoclave type F-250C (Pressure relieved 9/16-18 gland thread; $\frac{1}{4}$ OD high pressure tube 60° cone; available in SST for sensor range 5 only)
Level Transmitter (3051S_L)	
FF Seal	2-in. (DN 50), 3-in. (DN 80), or 4-in. (DN 100); ANSI Class 150, 300, or 600 flange; JIS 10K, 20K, or 40K flange; PN 10/16 or PN 40 flange
EF Seal	

Process-Wetted Parts

Process Isolating Diaphragms

Coplanar Sensor Module (3051S_C)	
316L SST (UNS S31603), Alloy C-276 (UNS N10276), Alloy 400 (UNS N04400), Tantalum (UNS R05440), Gold-Plated Alloy 400, Gold-plated 316L SST	
In-Line Sensor Module (3051S_T)	
316L SST (UNS S31603), Alloy C-276 (UNS N10276)	
Level Transmitter (3051S_L)	
FF Seal	316L SST, Alloy C-276, Tantalum
EF Seal	

Drain/Vent Valves

316 SST, Alloy C-276, or Alloy 400/K-500⁽¹⁾ material
(Drain vent seat: Alloy 400, Drain vent stem: Alloy K-500)

⁽¹⁾ Alloy 400/K-500 is not available with 3051S_L.

Process Flanges and Flange Adapters

Plated carbon steel
SST: CF-8M (Cast 316 SST) per ASTM A743
Cast C-276: CW-12MW per ASTM A494
Cast Alloy 400: M-30C per ASTM A494

Wetted O-rings

Glass-filled PTFE
(Graphite-filled PTFE with Isolating Diaphragm code 6)

⁽¹⁾ A 2% variation of the transmitter mA output is allowed before a safety trip. Trip values in the DCS or safety logic solver should be derated by 2%.

Non-Wetted Parts

3051S_L Mounting Flange

Zinc-cobalt plated CS or 316 SST

3051S_L Seal Extension

CF-3M (Cast 316L SST, material per ASTM A743) or
CW-12MW (Cast C-276, material per ASTM A494)

Electronics Housing

Low-copper aluminum alloy or CF-8M (Cast 316 SST)
NEMA 4X, IP 66, IP 68 (66 ft. (20 m) for 168 hours)

Coplanar Sensor Module Housing

SST: CF-3M (Cast 316L SST)

Bolts

Plated carbon steel per ASTM A449, Type 1
Austenitic 316 SST per ASTM F593
ASTM A453, Class D, Grade 660 SST
ASTM A193, Grade B7M alloy steel
ASTM A193, Class 2, Grade B8M SST
Alloy K-500

Sensor Module Fill Fluid

Silicone or inert halocarbon (Inert is not available with 3051S_CA). In-Line series uses Fluorinert®
FC-43.

Process Fill Fluid (Liquid Level Only)

3051S_L: Syltherm XLT, Silicone 704, Silicone 200, inert, glycerin and water, Neobee M-20,
propylene glycol and water.

Paint for Aluminum Housing

Polyurethane

Cover O-rings

Buna-N

Wireless Antenna

PBT/ polycarbonate (PC) integrated omnidirectional antenna

Power Module

Field replaceable, keyed connection eliminates the risk of incorrect installation, Intrinsically Safe
Lithium-thionyl chloride Power Module with PBT enclosure

Rosemount 3051S Series

Shipping Weights

Sensor Module Weights

Coplanar Sensor Module⁽¹⁾
3.1 lb (1,4 kg)
In-Line Sensor Module
1.4 lb (0,6 kg)

(1) Flange and bolts not included.

Transmitter Weights⁽¹⁾

Transmitter with Coplanar Sensor Module (3051S_C)	
Junction Box Housing, SST Flange	6.3 lb (2,8 kg)
PlantWeb Housing, SST Flange	6.7 lb (3,1 kg)
Transmitter with In-Line Sensor Module (3051S_T)	
Junction Box Housing	3.2 lb (1,4 kg)
PlantWeb Housing	3.7 lb (1,7 kg)

(1) Fully functional transmitter with sensor module, housing, terminal block, and covers. Does not include LCD display.

Transmitter Option Weights

Option Code	Option	Add lb (kg)
1J, 1K, 1L	SST PlantWeb Housing	3.5 (1,6)
2J	SST Junction Box Housing	3.4 (1,5)
7J	SST Quick Connect	0.4 (0,2)
2A, 2B, 2C	Aluminum Junction Box Housing	1.1 (0,5)
1A, 1B, 1C	Aluminum PlantWeb Housing	1.1 (0,5)
M5	LCD Display for Aluminum PlantWeb Housing ⁽¹⁾ , LCD Display for SST PlantWeb Housing ⁽¹⁾	0.8 (0,4) 1.6 (0,7)
B4	SST Mounting Bracket for Coplanar Flange	1.2 (0,5)
B1, B2, B3	Mounting Bracket for Traditional Flange	1.7 (0,8)
B7, B8, B9	Mounting Bracket for Traditional Flange with SST Bolts	1.7 (0,8)
BA, BC	SST Bracket for Traditional Flange	1.6 (0,7)
B4	SST Mounting Bracket for In-Line	1.3 (0,6)
F12, F22	SST Traditional Flange with SST Drain Vents ⁽²⁾	3.2 (1,5)
F13, F23	Cast C-276 Traditional Flange with Alloy C-276 Drain Vents ⁽²⁾	3.6 (1,6)
E12, E22	SST Coplanar Flange with SST Drain Vents ⁽²⁾	1.9 (0,9)
F14, F24	Cast Alloy 400 Traditional Flange with Alloy 400/K-500 Drain Vents ⁽²⁾	3.6 (1,6)
F15, F25	SST Traditional Flange with Alloy C-276 Drain Vents ⁽²⁾	3.2 (1,5)
G21	Level Flange—3 in., 150	12.6 (5,7)
G22	Level Flange—3 in., 300	15.9 (7,2)
G11	Level Flange—2 in., 150	6.8 (3,1)
G12	Level Flange—2 in., 300	8.2 (3,7)
G31	DIN Level Flange, SST, DN 50, PN 40	7.8 (3,5)
G41	DIN Level Flange, SST, DN 80, PN 40	13.0 (5,9)

(1) Includes LCD display and display cover.

(2) Includes mounting bolts.

Item	Weight in lb. (kg)
Aluminum Standard Cover	0.4 (0,2)
SST Standard Cover	1.3 (0,6)
Aluminum Display Cover	0.7 (0,3)
SST Display Cover	1.5 (0,7)
LCD Display ⁽¹⁾	0.1 (0,04)
Junction Box Terminal Block	0.2 (0,1)
PlantWeb Terminal Block	0.2 (0,1)
Power Module	0.5 (0,2)

(1) Display only.

3051S_L Weights Without SuperModule Platform, Housing, or Transmitter Options

Flange	Flush lb. (kg)	2-in. Ext. lb (kg)	4-in. Ext. lb (kg)	6-in. Ext. lb (kg)
2-in., 150	9.5 (4,3)	—	—	—
3-in., 150	15.7 (7,1)	16.4 (7,4)	17.6 (8,0)	18.9 (8,6)
4-in., 150	21.2 (9,6)	20.9 (9,5)	22.1 (10,0)	23.4 (10,6)
2-in., 300	11.3 (5,1)	—	—	—
3-in., 300	19.6 (8,9)	20.3 (9,2)	21.5 (9,8)	22.8 (10,3)
4-in., 300	30.4 (13,8)	30.3 (13,7)	31.5 (14,3)	32.8 (14,9)
2-in., 600	12.8 (5,8)	—	—	—
3-in., 600	22.1 (10,0)	22.8 (10,3)	24.0 (10,9)	25.3 (11,5)
DN 50 / PN 40	11.3 (5,1)	—	—	—
DN 80 / PN 40	16.0 (7,3)	16.7 (7,6)	17.9 (8,1)	19.2 (8,7)
DN 100 / PN 10/16	11.2 (5,1)	11.9 (5,4)	13.1 (5,9)	14.4 (6,5)
DN 100 / PN 40	12.6 (5,7)	13.3 (6,0)	14.5 (6,6)	15.8 (7,1)

Rosemount 3051S Series

DIMENSIONAL DRAWINGS

Figure A-1. Transmitter with Coplanar Sensor Module and Flange

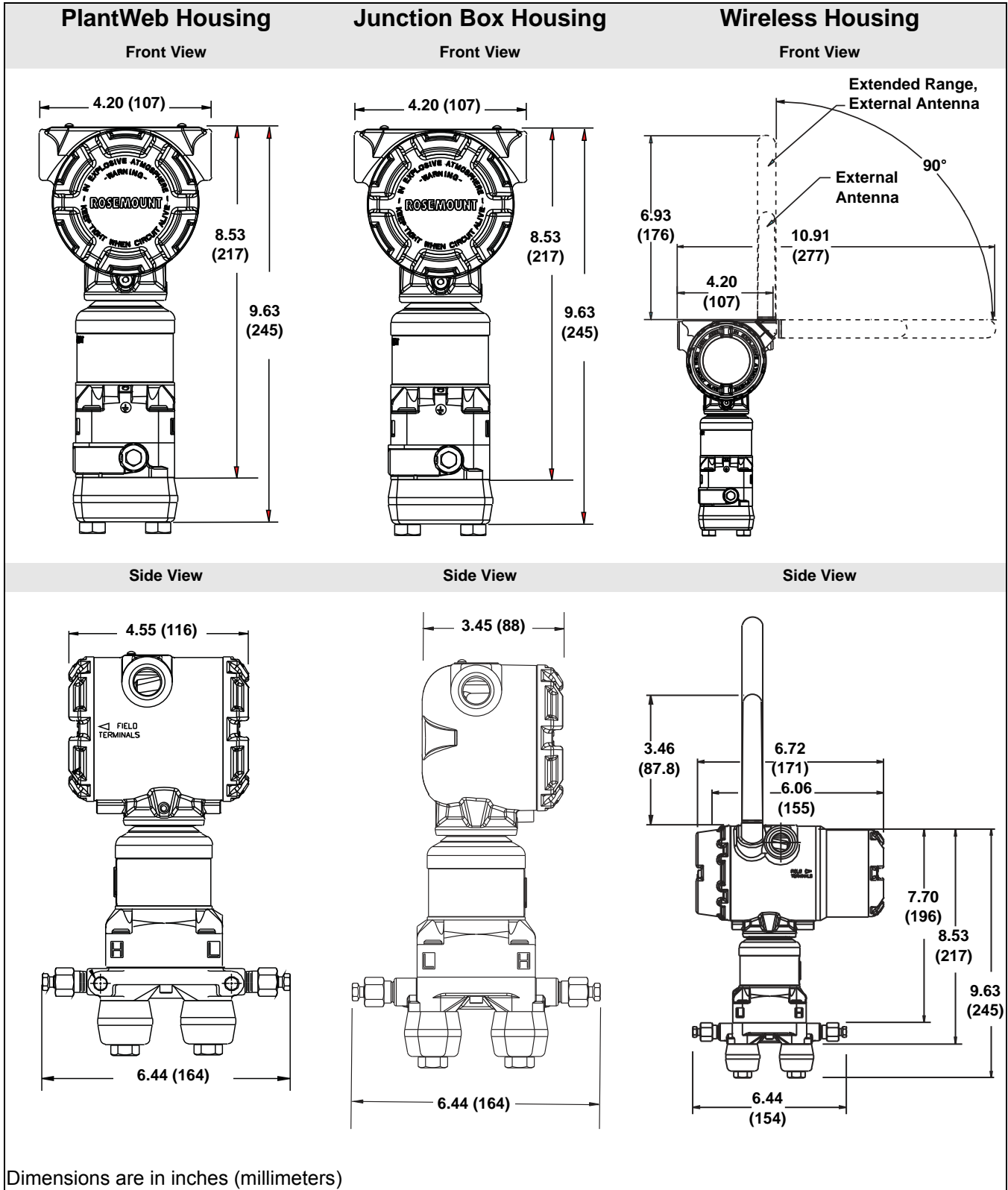
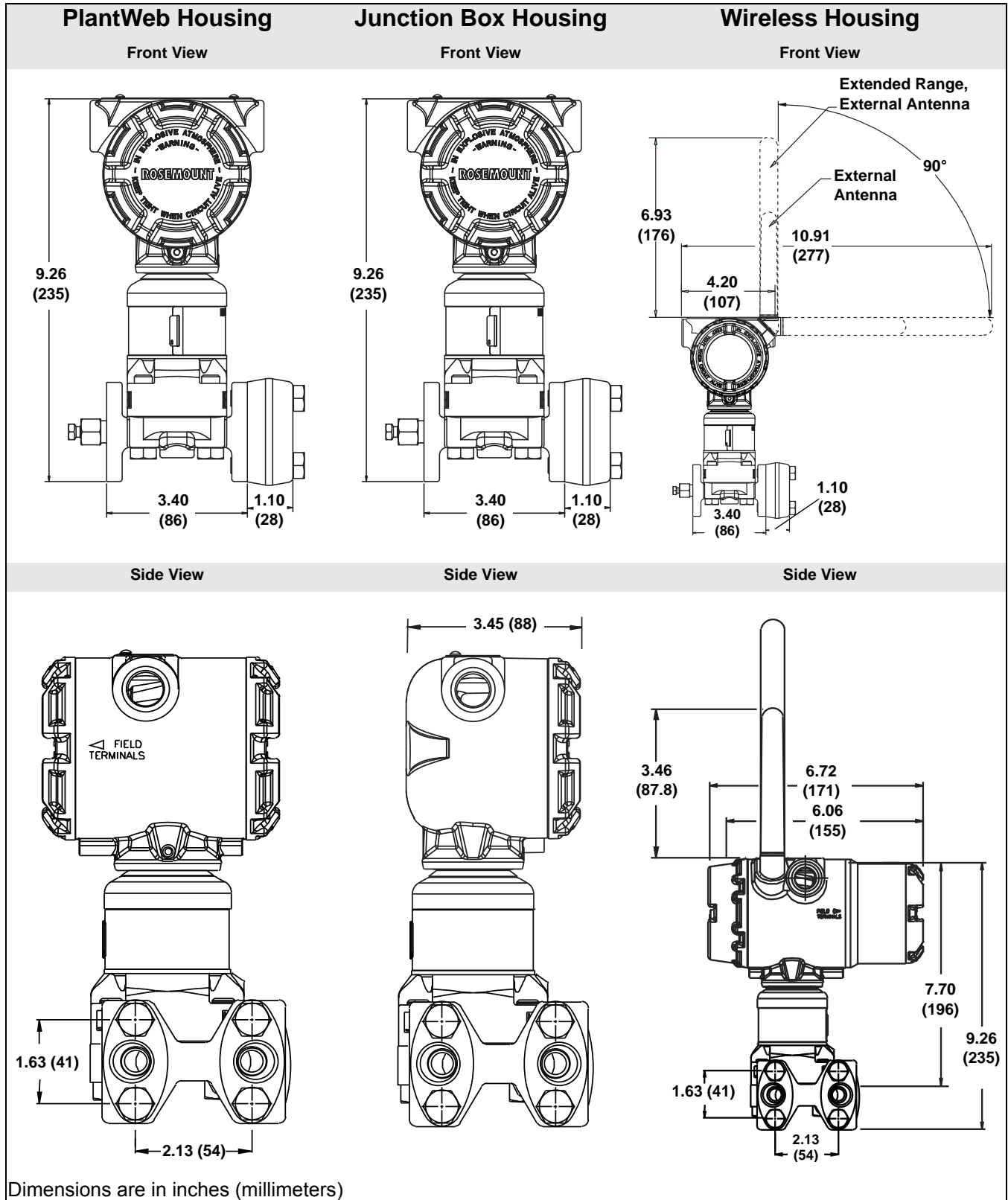

Figure A-2. Transmitter with Coplanar Sensor Module and Traditional Flange



Rosemount 3051S Series

Figure A-3. Transmitter with In-Line Sensor Module

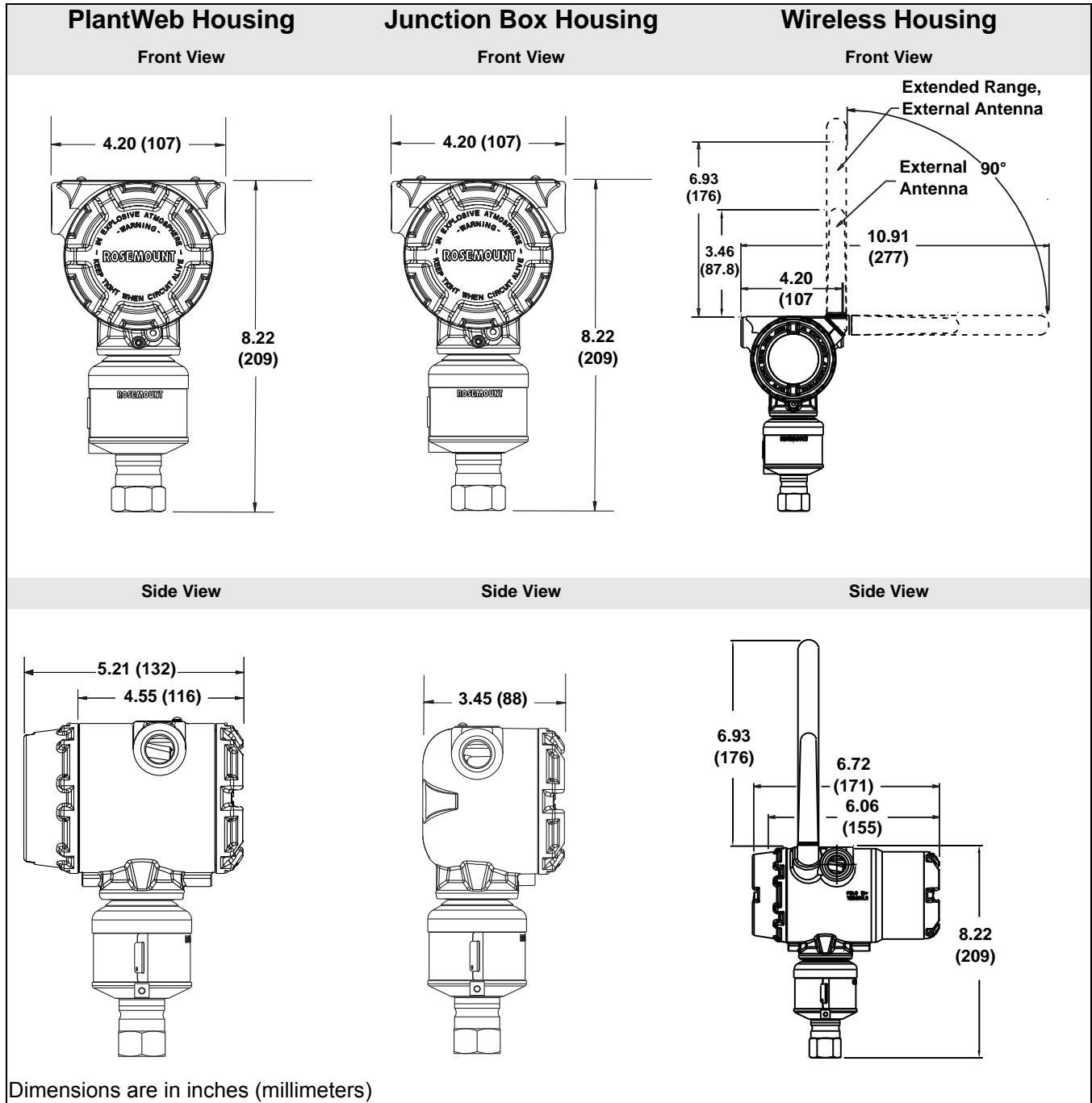
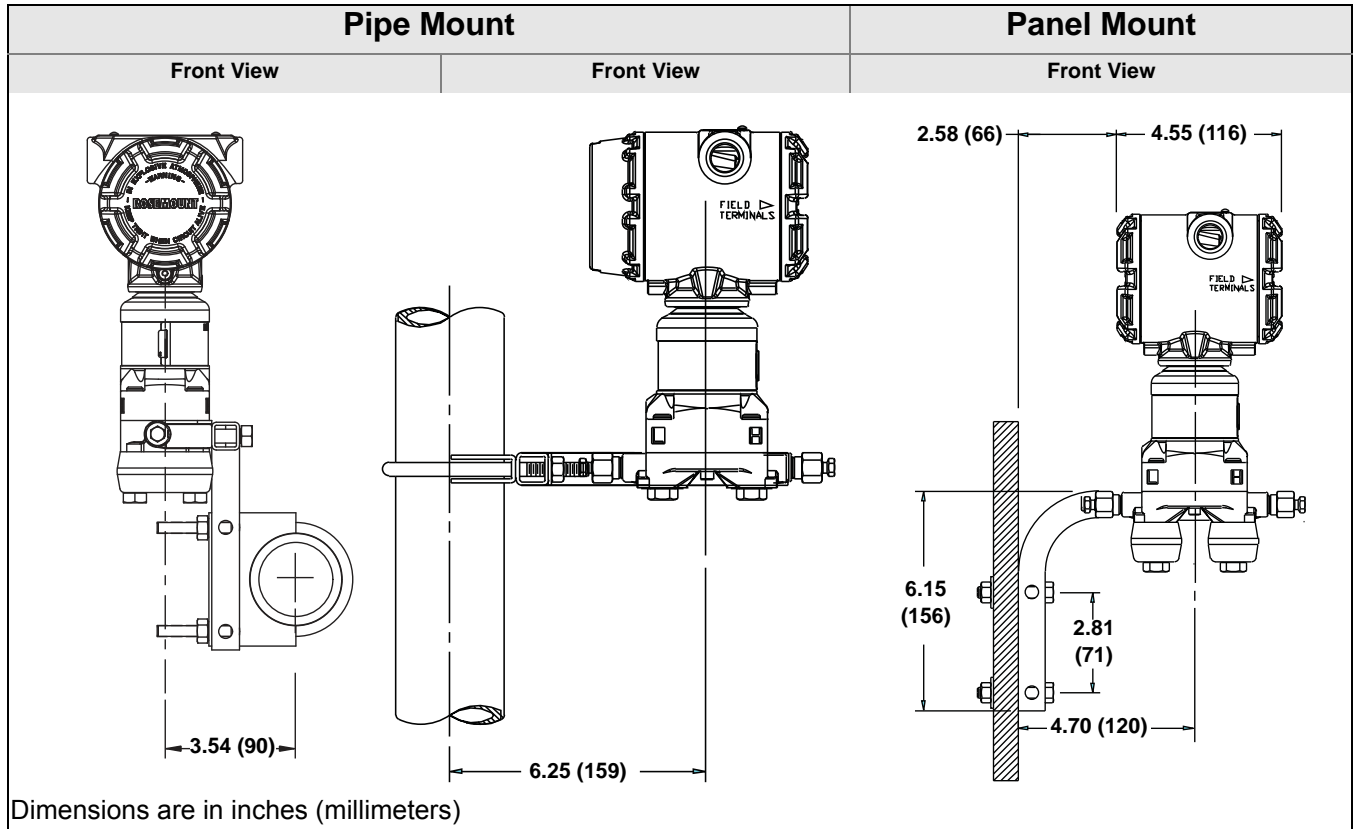

Figure A-4. Coplanar Mounting Configurations (B4 Bracket)



Rosemount 3051S Series

Figure A-5. Traditional Mounting Configurations

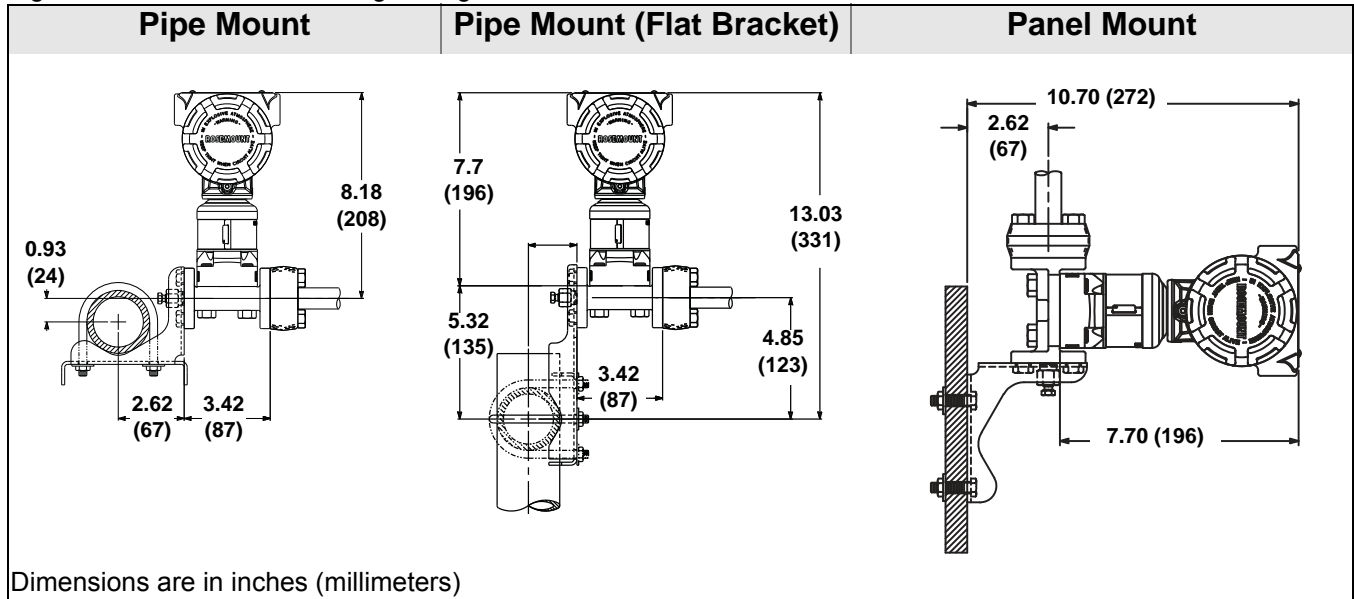

Figure A-6. In-Line Mounting Configurations (B4 Bracket)

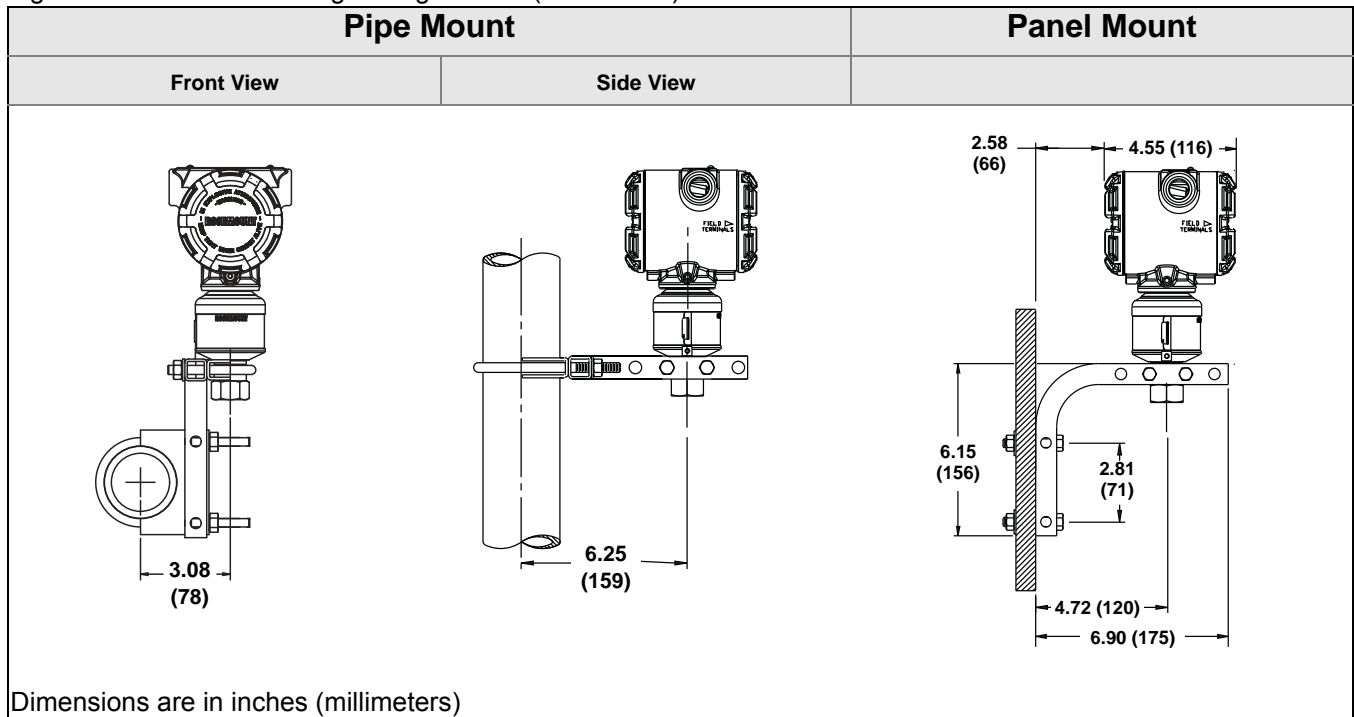
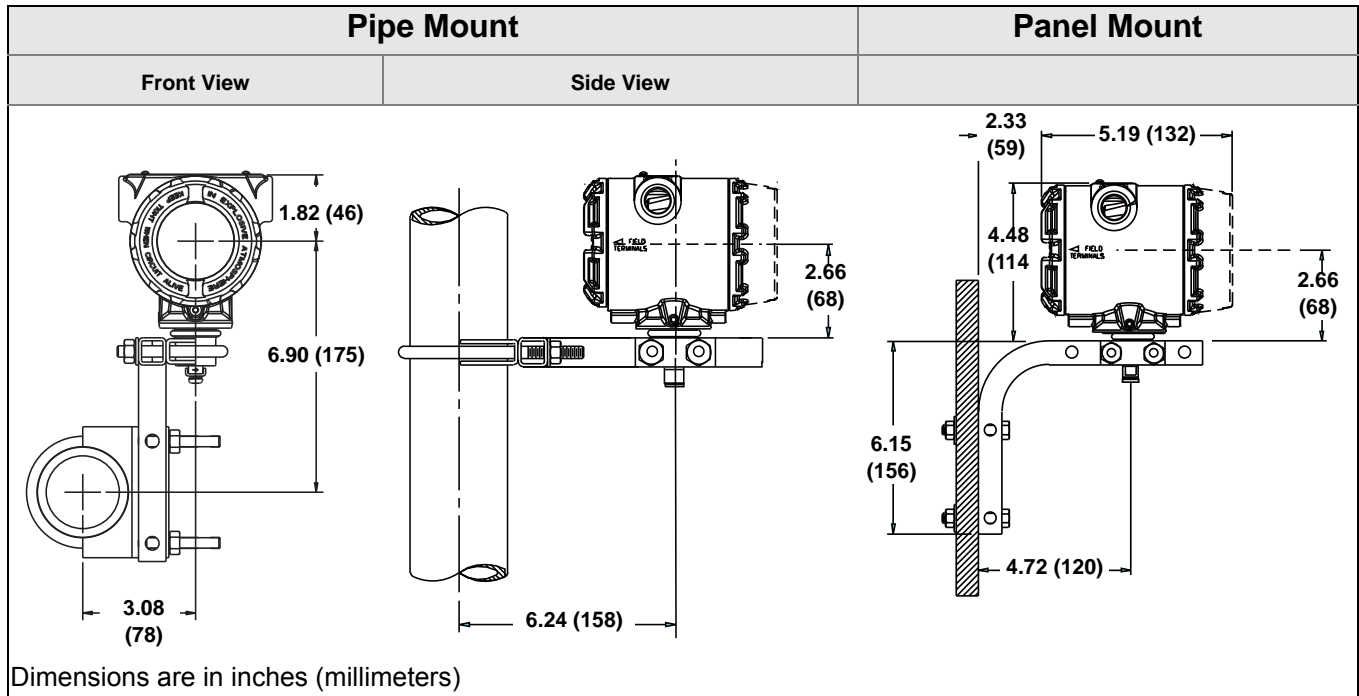

Figure A-7. Remote Display Mounting Configurations (B4 Bracket)



(1) Tolerances are 0.040 (1,02), -0.020 (0,51).

Rosemount 3051S Series

Figure A-8. Rosemount 3051S_L Liquid Level Transmitter

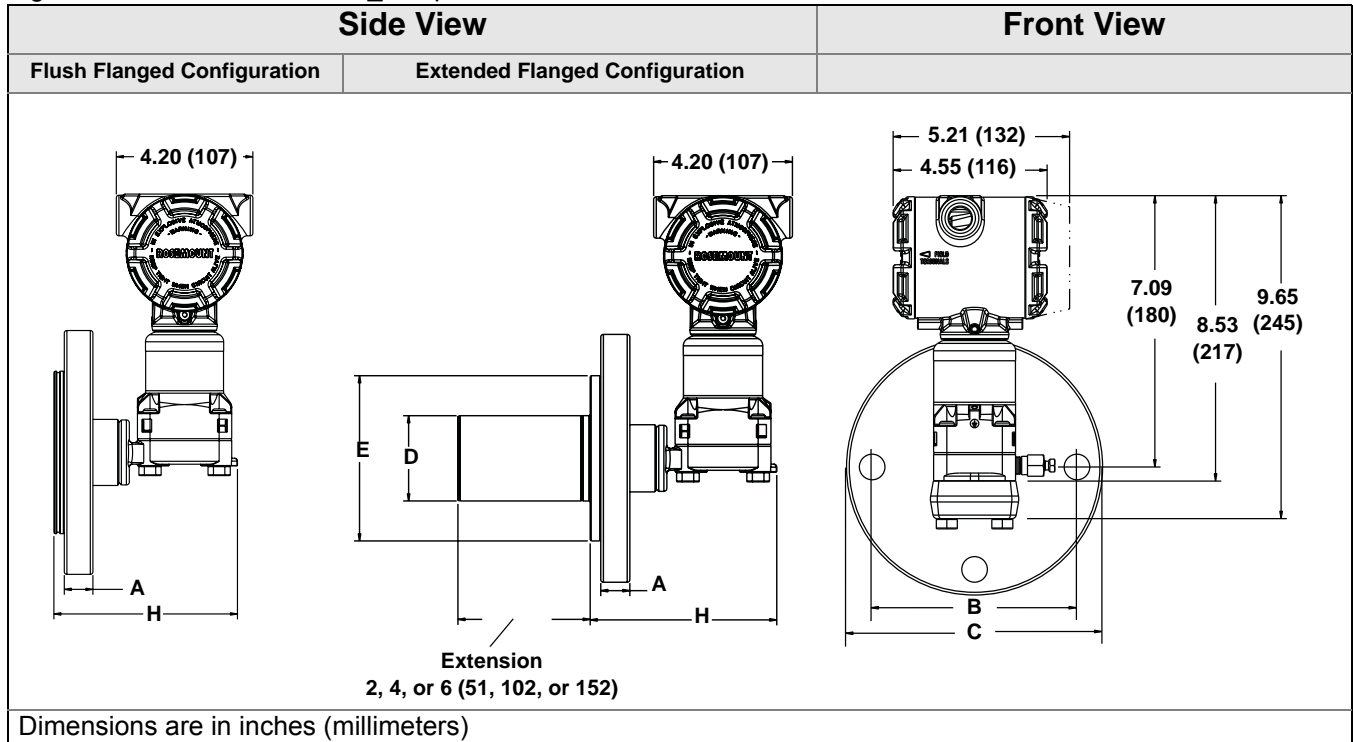

Class	Pipe Size	Flange Thickness A	Bolt Circle Diameter B	Outside Diameter C	No. of Bolts	Bolt Hole Diameter	Extension Diameter ⁽¹⁾ D	E	H
ASME B16.5 (ANSI) 150	2 (51)	0.69 (18)	4.75 (121)	6.0 (152)	4	0.75 (19)	N/A	3.6 (92)	5.65 (143)
	3 (76)	0.88 (22)	6.0 (152)	7.5 (191)	4	0.75 (19)	2.58 (66)	5.0 (127)	5.65 (143)
	4 (102)	0.88 (22)	7.5 (191)	9.0 (229)	8	0.75 (19)	3.5 (89)	6.2 (158)	5.65 (143)
ASME B16.5 (ANSI) 300	2 (51)	0.82 (21)	5.0 (127)	6.5 (165)	8	0.75 (19)	N/A	3.6 (92)	5.65 (143)
	3 (76)	1.06 (27)	6.62 (168)	8.25 (210)	8	0.88 (22)	2.58 (66)	5.0 (127)	5.65 (143)
	4 (102)	1.19 (30)	7.88 (200)	10.0 (254)	8	0.88 (22)	3.5 (89)	6.2 (158)	5.65 (143)
ASME B16.5 (ANSI) 600	2 (51)	1.00 (25)	5.0 (127)	6.5 (165)	8	0.75 (19)	N/A	3.6 (92)	7.65 (194)
	3 (76)	1.25 (32)	6.62 (168)	8.25 (210)	8	0.88 (22)	2.58 (66)	5.0 (127)	7.65 (194)
DIN 2501 PN 10-40	DN 50	20 mm	125 mm	165 mm	4	18 mm	N/A	4.0 (102)	5.65 (143)
DIN 2501 PN 25/40	DN 80	24 mm	160 mm	200 mm	8	18 mm	66 mm	5.4 (138)	5.65 (143)
	DN 100	24 mm	190 mm	235 mm	8	22 mm	89 mm	6.2 (158)	5.65 (143)
DIN 2501 PN 10/16	DN 100	20 mm	180 mm	220 mm	8	18 mm	89 mm	6.2 (158)	5.65 (143)

(1) Tolerances are 0.040 (1.02), -0.020 (0.51).

ORDERING INFORMATION

Table A-1. Rosemount 3051S Scalable Coplanar Pressure Transmitter Ordering Information

★ The Standard offering represents the most common options. The starred options (★) should be selected for best delivery.
The Expanded offering is subject to additional delivery lead time.

Model	Transmitter Type			
3051S	Scalable Pressure Transmitter			
Performance Class				
Standard				Standard
1	Ultra: 0.025 percent span accuracy, 200:1 rangedown, 10-yr stability, 12-yr limited warranty			★
3 ⁽¹⁾	Ultra for Flow: 0.04 percent reading accuracy, 200:1 turndown, 10-yr stability, 12-yr ltd warranty			★
2	Classic: 0.055 percent span accuracy, 100:1 rangedown, 5-yr stability			★
Connection Type				
Standard				Standard
C	Coplanar			★
Measurement Type⁽²⁾				
Standard				Standard
D	Differential			★
G	Gage			★
Expanded				
A	Absolute			
Pressure Range				
	Differential	Gage	Absolute	
Standard				Standard
1A	-25 to 25 inH ₂ O (-62,2 to 62,2 mbar)	-25 to 25 inH ₂ O (-62,2 to 62,2 mbar)	0 to 30 psia (0 to 2,06 bar)	★
2A	-250 to 250 inH ₂ O (-623 to 623 mbar)	-250 to 250 inH ₂ O (-623 to 623 mbar)	0 to 150 psia (0 to 10,34 bar)	★
3A	-1000 to 1000 inH ₂ O (-2,5 to 2,5 bar)	-393 to 1000 inH ₂ O (-0,98 to 2,5 bar)	0 to 800 psia (0 to 55,2 bar)	★
4A	-300 to 300 psi (-20,7 to 20,7 bar)	-14.2 to 300 psig (-0,98 to 21 bar)	0 to 4000 psia (0 to 275,8 bar)	★
5A	-2000 to 2000 psi (-137,9 to 137,9 bar)	-14.2 to 2000 psig (-0,98 to 137,9 bar)	N/A	★
Expanded				
0A ⁽³⁾	-3 to 3 inH ₂ O (-7,47 to 7,47 mbar)	N/A	0 to 5 psia (0 to 0,34 bar)	
Isolating Diaphragm				
Standard				Standard
2 ⁽⁴⁾	316L SST			★
3 ⁽⁴⁾	Alloy C-276			★
Expanded				
4	Alloy 400			
5 ⁽⁵⁾	Tantalum			
6	Gold-Plated Alloy 400 (includes Graphite-Filled PTFE o-ring)			
7	Gold-plated 316L SST			
Process Connection		Size	Materials of Construction	
			Flange Material	Drain Vent Bolting
Standard				Standard
000	None			★
A11 ⁽⁶⁾	Assemble to Rosemount 305 Integral Manifold			★
A12 ⁽⁶⁾	Assemble to Rosemount 304 or AMF Manifold and SST traditional flange			★
B11 ⁽⁶⁾⁽⁷⁾⁽⁸⁾	Assemble to one Rosemount 1199 Seal	SST		★
B12 ⁽⁶⁾⁽⁷⁾⁽⁸⁾	Assemble to two Rosemount 1199 Seals	SST		★
C11 ⁽⁶⁾	Assemble to Rosemount 405 Primary Element			★
D11 ⁽⁶⁾	Assemble to Rosemount 1195 integral orifice and Rosemount 305 Integral Manifold			★
EA2 ⁽⁶⁾	Assemble to Rosemount Annubar [®] Primary Element with Coplanar flange	SST	316 SST	★
EA3 ⁽⁶⁾	Assemble to Rosemount Annubar Primary Element with Coplanar flange	Cast C-276	Alloy C-276	★
EA5 ⁽⁶⁾	Assemble to Rosemount Annubar Primary Element with Coplanar flange	SST	Alloy C-276	★

Rosemount 3051S Series

Table A-1. Rosemount 3051S Scalable Coplanar Pressure Transmitter Ordering Information

★ The Standard offering represents the most common options. The starred options (★) should be selected for best delivery.
The Expanded offering is subject to additional delivery lead time.

E11	Coplanar flange	1/4-18 NPT	CS	316 SST		★
E12	Coplanar flange	1/4-18 NPT	SST	316 SST		★
E13 ⁽⁴⁾	Coplanar flange	1/4-18 NPT	Cast C-276	Alloy C-276		★
E14	Coplanar flange	1/4-18 NPT	Cast Alloy 400	Alloy 400/K-500		★
E15 ⁽⁴⁾	Coplanar flange	1/4-18 NPT	SST	Alloy C-276		★
E16 ⁽⁴⁾	Coplanar flange	1/4-18 NPT	CS	Alloy C-276		★
E21	Coplanar flange	RC 1/4	CS	316 SST		★
E22	Coplanar flange	RC 1/4	SST	316 SST		★
E23 ⁽⁴⁾	Coplanar flange	RC 1/4	Cast C-276	Alloy C-276		★
E24	Coplanar flange	RC 1/4	Cast Alloy 400	Alloy 400/K-500		★
E25 ⁽⁴⁾	Coplanar flange	RC 1/4	SST	Alloy C-276		★
E26 ⁽⁴⁾	Coplanar flange	RC 1/4	CS	Alloy C-276		★
F12	Traditional flange	1/4-18 NPT	SST	316 SST		★
F13 ⁽⁴⁾	Traditional flange	1/4-18 NPT	Cast C-276	Alloy C-276		★
F14	Traditional flange	1/4-18 NPT	Cast Alloy 400	Alloy 400/K-500		★
F15 ⁽⁴⁾	Traditional flange	1/4-18 NPT	SST	Alloy C-276		★
F22	Traditional flange	RC 1/4	SST	316 SST		★
F23 ⁽⁴⁾	Traditional flange	RC 1/4	Cast C-276	Alloy C-276		★
F24	Traditional flange	RC 1/4	Cast Alloy 400	Alloy 400/K-500		★
F25 ⁽⁴⁾	Traditional flange	RC 1/4	SST	Alloy C-276		★
F52	DIN-compliant traditional flange	1/4-18 NPT	SST	316 SST	7/16-in. bolting	★
G11	Vertical mount level flange	2-in. ANSI class 150	SST	316 SST		★
G12	Vertical mount level flange	2-in. ANSI class 300	SST	316 SST		★
G21	Vertical mount level flange	3-in. ANSI class 150	SST	316 SST		★
G22	Vertical mount level flange	3-in. ANSI class 300	SST	316 SST		★
G31	Vertical mount level flange	DIN- DN 50 PN 40	SST	316 SST		★
G41	Vertical mount level flange	DIN- DN 80 PN 40	SST	316 SST		★
Expanded						
F32	Bottom vent traditional flange	1/4-18 NPT	SST	316 SST		★
F42	Bottom vent traditional flange	RC 1/4	SST	316 SST		★
F62	DIN-compliant traditional flange	1/4-18 NPT	SST	316 SST	M10 bolting	★
F72	DIN-compliant traditional flange	1/4-18 NPT	SST	316 SST	M12 bolting	★
Transmitter Output						
Standard						Standard
A	4-20 mA with digital signal based on HART® protocol					★
F ⁽⁹⁾	FOUNDATION™ fieldbus protocol					★
X ⁽¹⁰⁾	Wireless (Requires wireless options and wireless PlantWeb housing)					★
Housing Style			Material	Conduit Entry Size		
Standard						Standard
00	None (SuperModule spare part, order output code A)					★
1A	PlantWeb housing		Aluminum	1/2-14 NPT		★
1B	PlantWeb housing		Aluminum	M20 x 1.5		★
1J	PlantWeb housing		SST	1/2-14 NPT		★
1K	PlantWeb housing		SST	M20 x 1.5		★
5A ⁽²²⁾	Wireless PlantWeb housing		Aluminum	1/2-14 NPT		★
5J ⁽²²⁾	Wireless PlantWeb housing		SST	1/2-14 NPT		★
2A	Junction Box housing		Aluminum	1/2-14 NPT		★
2B	Junction Box housing		Aluminum	M20 x 1.5		★
2J	Junction Box housing		SST	1/2-14 NPT		★
2E	Junction Box Housing with output for remote display and interface		Aluminum	1/2-14 NPT		★
2F	Junction Box Housing with output for remote display and interface		Aluminum	M20 x 1.5		★
2M	Junction Box Housing with output for remote display and interface		SST	1/2-14 NPT		★
7J ⁽¹¹⁾	Quick Connect (A size Mini, 4-pin male termination)		SST			★

Table A-1. Rosemount 3051S Scalable Coplanar Pressure Transmitter Ordering Information

★ The Standard offering represents the most common options. The starred options (★) should be selected for best delivery. The Expanded offering is subject to additional delivery lead time.

Expanded			
1C	PlantWeb housing	Aluminum	G ^{1/2}
1L	PlantWeb housing	SST	G ^{1/2}
2C	Junction Box housing	Aluminum	G ^{1/2}
2G	Junction Box Housing with output for remote display and interface	Aluminum	G ^{1/2}

Wireless Options (Requires option code X and wireless PlantWeb housing)

Update Rate		
Standard		Standard
WA	User Configurable Update Rate	★
Operating Frequency and Protocol		
Standard		Standard
3	2.4 GHz DSSS, IEC 62591 (WirelessHART)	★
Omnidirectional Wireless Antenna		
Standard		Standard
WK	External Antenna	★
WM	Extended Range, External Antenna	★
SmartPower™		
Standard		Standard
1 ⁽¹²⁾	Compatible with Black Power Module (I.S. Power Module Sold Separately)	★

Other Options (Include with selected model number)

PlantWeb Control Functionality		
Standard		Standard
A01 ⁽¹³⁾	FOUNDATION fieldbus Advanced Control Function Block Suite	★
PlantWeb Diagnostic Functionality		
Standard		Standard
D01 ⁽¹³⁾	FOUNDATION fieldbus Diagnostics Suite	★
DA2 ⁽¹³⁾⁽¹⁴⁾	Advanced HART Diagnostics Suite	★
PlantWeb Enhanced Measurement Functionality		
Standard		Standard
H01 ⁽¹³⁾⁽¹⁵⁾	FOUNDATION fieldbus Fully Compensated Mass Flow Block	★
Mounting Bracket ⁽¹⁶⁾		
Standard		Standard
B4	Coplanar flange bracket, all SST, 2-in. pipe and panel	★
B1	Traditional flange bracket, CS, 2-in. pipe	★
B2	Traditional flange bracket, CS, panel	★
B3	Traditional flange flat bracket, CS, 2-in. pipe	★
B7	Traditional flange bracket, B1 with SST bolts	★
B8	Traditional flange bracket, B2 with SST bolts	★
B9	Traditional flange bracket, B3 with SST bolts	★
BA	Traditional flange bracket, B1, all SST	★
BC	Traditional flange bracket, B3, all SST	★
Software Configuration		
Standard		Standard
C1 ⁽¹⁷⁾	Custom software configuration (Requires Configuration Data Sheet)	★
C2	Custom flow configuration (Requires H01 and Configuration Data Sheet)	★
Gage Pressure Calibration		
Standard		Standard
C3	Gage pressure calibration on Rosemount 3051S_CA4 only	★
Alarm Limit		
Standard		Standard
C4 ⁽¹³⁾⁽¹⁷⁾	NAMUR alarm and saturation levels, high alarm	★
C5 ⁽¹³⁾⁽¹⁷⁾	NAMUR alarm and saturation levels, low alarm	★
C6 ⁽¹³⁾⁽¹⁷⁾	Custom alarm and saturation signal levels, high alarm (Requires C1 and Configuration Data Sheet)	★
C7 ⁽¹³⁾⁽¹⁷⁾	Custom alarm and saturation signal levels, low alarm (Requires C1 and Configuration Data Sheet)	★
C8 ⁽¹³⁾⁽¹⁷⁾	Low alarm (standard Rosemount alarm and saturation levels)	★

Rosemount 3051S Series

Table A-1. Rosemount 3051S Scalable Coplanar Pressure Transmitter Ordering Information

★ The Standard offering represents the most common options. The starred options (★) should be selected for best delivery.
The Expanded offering is subject to additional delivery lead time.

Hardware Adjustments		
Standard		Standard
D1 ⁽¹³⁾⁽¹⁷⁾⁽¹⁸⁾	Hardware adjustments (zero, span, alarm, security)	★
Flange Adapter		
Standard		Standard
D2 ⁽¹⁶⁾	1/2-14 NPT flange adapter	★
Expanded		
D9 ⁽¹⁶⁾	RC1/2 SST flange adapter	
Custody Transfer		
Standard		Standard
D3 ⁽¹⁹⁾	Measurement Canada Accuracy Approval	★
Ground Screw		
Standard		Standard
D4	External ground screw assembly	★
Drain/Vent Valve		
Standard		Standard
D5 ⁽¹⁶⁾	Delete transmitter drain/vent valves (install plugs)	★
Expanded		
D7 ⁽¹⁶⁾	Coplanar flange without drain/vent ports	
Conduit Plug		
Standard		Standard
DO ⁽²⁰⁾	316 SST Conduit Plug	★
Product Certifications⁽²¹⁾		
Standard		Standard
E1	ATEX Flameproof	★
I1	ATEX Intrinsic Safety	★
IA	ATEX FISCO Intrinsic Safety (FOUNDATION™ fieldbus protocol only)	★
N1	ATEX Type n	★
K1	ATEX Flameproof, Intrinsic Safety, Type n, Dust	★
ND	ATEX Dust	★
E4	TIIS Flameproof	★
I4 ⁽²²⁾	TIIS Intrinsic Safety	★
E5	FM Explosion-proof, Dust Ignition-proof	★
I5	FM Intrinsically Safe, Division 2	★
IE	FM FISCO Intrinsically Safe (FOUNDATION™ fieldbus protocol only)	★
K5	FM Explosion-proof, Dust Ignition-proof, Intrinsically Safe, Division 2	★
E6 ⁽²³⁾	CSA Explosion-proof, Dust Ignition-proof, Division 2	★
I6	CSA Intrinsically Safe	★
IF	CSA FISCO Intrinsically Safe (FOUNDATION™ fieldbus protocol only)	★
K6 ⁽²³⁾	CSA Explosion-proof, Dust Ignition-proof, Intrinsically Safe, Division 2	★
E7	IECEX Flameproof, Dust Ignition-proof	★
I7	IECEX Intrinsic Safety	★
IG	IECEX FISCO Intrinsic Safety (FOUNDATION™ fieldbus protocol only)	★
N7	IECEX Type n	★
K7	IECEX Flameproof, Dust Ignition-proof, Intrinsic Safety, Type n	★
E2	INMETRO Flameproof	★
I2	INMETRO Intrinsic Safety	★
K2	INMETRO Flameproof, Intrinsic Safety	★
E3	China Flameproof	★
I3	China Intrinsic Safety	★
N3	China Type n	★
KA ⁽²³⁾	ATEX and CSA Flameproof, Intrinsically Safe, Division 2	★
KB ⁽²³⁾	FM and CSA Explosion-proof, Dust Ignition-proof, Intrinsically Safe, Division 2	★
KC	FM and ATEX Explosion-proof, Intrinsically Safe, Division 2	★
KD ⁽²³⁾	FM, CSA, and ATEX Explosion-proof, Intrinsically Safe	★

Table A-1. Rosemount 3051S Scalable Coplanar Pressure Transmitter Ordering Information

★ The Standard offering represents the most common options. The starred options (★) should be selected for best delivery.
The Expanded offering is subject to additional delivery lead time.

Sensor Fill Fluid		
Standard		Standard
L1 ⁽²⁴⁾	Inert sensor fill fluid	★
O-ring		
Standard		Standard
L2	Graphite-filled PTFE o-ring	★
Bolting Material		
Standard		Standard
L4 ⁽¹⁶⁾	Austenitic 316 SST bolts	★
L5 ⁽⁴⁾⁽¹⁶⁾	ASTM A 193, Grade B7M bolts	★
L6 ⁽¹⁶⁾	Alloy K-500 bolts	★
L7 ⁽⁴⁾⁽¹⁶⁾	ASTM A453, Class D, Grade 660 bolts	★
L8 ⁽¹⁶⁾	ASTM A193, Class 2, Grade B8M bolts	★
Display Type⁽²⁵⁾		
Standard		Standard
M5	PlantWeb LCD Display	★
M7 ⁽¹³⁾⁽²⁶⁾⁽²⁷⁾	Remote mount LCD display and interface, PlantWeb housing, no cable, SST bracket	★
M8 ⁽¹³⁾⁽²⁶⁾	Remote mount LCD display and interface, PlantWeb housing, 50 ft. (15 m) cable, SST bracket	★
M9 ⁽¹³⁾⁽²⁶⁾	Remote mount LCD display and interface, PlantWeb housing, 100-ft. (31 m) cable, SST bracket	★
Pressure Testing		
Expanded		
P1 ⁽²⁸⁾	Hydrostatic testing with certificate	
Special Cleaning		
Expanded		
P2 ⁽¹⁶⁾	Cleaning for special services	
P3 ⁽¹⁶⁾	Cleaning for less than 1PPM chlorine/fluorine	
Maximum Static Line Pressure		
Standard		Standard
P9	4500 psig (310 bar) static pressure limit (Rosemount 3051S_CD only)	★
P0 ⁽²⁹⁾	6092 psig (420 bar) static pressure limit (Rosemount 3051S2CD only)	★
Calibration Certification		
Standard		Standard
Q4	Calibration certificate	★
QP	Calibration certificate and tamper evident seal	★
Material Traceability Certification		
Standard		Standard
Q8	Material traceability certification per EN 10204 3.1	★
Quality Certification for Safety		
Standard		Standard
QS ⁽¹³⁾⁽¹⁷⁾	Prior-use certificate of FMEDA Data	★
QT ⁽³⁰⁾	Safety-certified to IEC 61508 with certificate of FMEDA data	★
Transient Protection		
Standard		Standard
T1 ⁽³¹⁾⁽³²⁾	Transient terminal block	★
Drinking Water Approval		
Standard		Standard
DW ⁽³³⁾	NSF Drinking Water Approval	★
Surface Finish Certification		
Standard		Standard
Q16	Surface finish certification for sanitary remote seals	★
Toolkit Total System Performance Reports		
Standard		Standard
QZ	Remote Seal System Performance Calculation Report	★

Rosemount 3051S Series

Table A-1. Rosemount 3051S Scalable Coplanar Pressure Transmitter Ordering Information

★ The Standard offering represents the most common options. The starred options (★) should be selected for best delivery.
The Expanded offering is subject to additional delivery lead time.

Conduit Electrical Connector		
Standard		Standard
GE ⁽³⁴⁾	M12, 4-pin, Male Connector (eurofast [®])	★
GM ⁽³⁴⁾	A size Mini, 4-pin, Male Connector (minifast [®])	★
Typical Model Number: 3051S1CD 2A 2 E12 A 1A DA2 B4 M5		

- (1) This option is only available with range codes 2A and 3A, 316L SST or Alloy C-276 isolating diaphragm and silicone fill fluid.
- (2) Performance Class code 3 is available with Measurement Type code D only.
- (3) 3051S_CD0 is only available with traditional flange, 316L SST diaphragm material, and Bolting option L4.
- (4) Materials of Construction comply with metallurgical requirements highlighted within NACE MR0175/ISO 15156 for sour oil field production environments. Environmental limits apply to certain materials. Consult latest standard for details. Selected materials also conform to NACE MR0103 for sour refining environments.
- (5) Tantalum diaphragm material is only available for ranges 2A - 5A, differential and gage.
- (6) "Assemble to" items are specified separately and require a completed model number. Process connection option codes B12, C11, D11, EA2, EA3, and EA5 are only available on differential Measurement Type, code D.
- (7) Consult an Emerson Process Management representative for performance specifications.
- (8) Not available with performance class code 3.
- (9) Requires PlantWeb housing.
- (10) Available approvals are FM Intrinsically Safe, Division 2 (option code I5), CSA Intrinsically Safe (option code I6), ATEX Intrinsic Safety (option code I1), and IECEx Intrinsic Safety (option code I7).
- (11) Available with output code A only. Available approvals are FM Intrinsically Safe, Division 2 (option code I5), ATEX Intrinsic Safety (option code I1), or IECEx Intrinsic Safety (option code I7). Contact an Emerson Process Management representative for additional information.
- (12) Long-Life Power Module must be shipped separately, order Part #00753-9220-0001.
- (13) Not available with output code X.
- (14) Requires PlantWeb housing and output code A. Includes Hardware Adjustments as standard.
- (15) Requires Rosemount Engineering Assistant to configure.
- (16) Not available with process connection option code A11.
- (17) Not available with output code F.
- (18) Not available with housing style codes 00, 2E, 2F, 2G, 2M, 5A, 5J, or 7J.
- (19) Requires PlantWeb housing and Hardware Adjustments option code D1. Limited availability depending on transmitter type and range. Contact an Emerson Process Management representative for additional information.
- (20) Transmitter is shipped with 316 SST conduit plug (uninstalled) in place of standard carbon steel conduit plug.
- (21) Valid when SuperModule Platform and housing have equivalent approvals.
- (22) Only available with output code X.
- (23) Not available with M20 or G ½ conduit entry size.
- (24) Only available on differential and gage measurement types. Silicone fill fluid is standard.
- (25) Not available with Housing code 7J.
- (26) Not available with output code F, option code DA2, or option code QT.
- (27) See the 3051S Reference Manual (document number 00809-0100-4801) for cable requirements. Contact an Emerson Process Management representative for additional information.
- (28) P1 is not available with 3051S_CA0.
- (29) Requires 316L SST, Alloy C-276, or Gold-plated 316L SST diaphragm material, assemble to Rosemount 305 integral manifold or DIN-compliant traditional flange process connection, and bolting option L8. Limited to Pressure Range (Differential), ranges 2A – 5A.
- (30) Not available with output code F or X. Not available with housing code 7J.
- (31) Not available with Housing code 00, 5A, 5J, or 7J.
- (32) The T1 option is not needed with FISCO Product Certifications; transient protection is included in the FISCO product certification codes IA, IE, IF, and IG.
- (33) Requires 316L SST diaphragm material, glass-filled PTFE O-ring (standard), and Process Connection code E12 or F12.
- (34) Not available with Housing code 00, 5A, 5J, or 7J. Available with Intrinsically Safe approvals only. For FM Intrinsically Safe, Division 2 (option code I5) or FM FISCO Intrinsically Safe (option code IE), install in accordance with Rosemount drawing 03151-1009 to maintain outdoor rating (NEMA 4X and IP66).

Table A-2. Rosemount 3051S Scalable In-Line Pressure Transmitter Ordering Information

★ The Standard offering represents the most common options. The starred options (★) should be selected for best delivery. The Expanded offering is subject to additional delivery lead time.

Model	Transmitter Type		
3051S	Scalable Pressure Transmitter		
Performance Class			
Standard			Standard
1	Ultra: 0.025 percent span accuracy, 200:1 rangedown, 10-yr stability, 12-yr limited warranty		★
2	Classic: 0.055 percent span accuracy, 100:1 rangedown, 5-yr stability		★
Connection Type			
Standard			Standard
T	In-Line		★
Measurement Type			
Standard			Standard
G	Gage		★
A	Absolute		★
Pressure Range			
	Gage	Absolute	
Standard			Standard
1A	-14.7 to 30 psi (-1,0 to 2,1 bar)	0 to 30 psia (2,1 bar)	★
2A	-14.7 to 150 psi (-1,0 to 10,3 bar)	0 to 150 psia (10,3 bar)	★
3A	-14.7 to 800 psi (-1,0 to 55 bar)	0 to 800 psia (55 bar)	★
4A	-14.7 to 4000 psi (-1,0 to 276 bar)	0 to 4000 psia (276 bar)	★
5A	-14.7 to 10000 psi (-1,0 to 689 bar)	0 to 10000 psia (689 bar)	★
Isolating Diaphragm			
Standard			Standard
2 ⁽¹⁾	316L SST		★
3 ⁽¹⁾	Alloy C-276		★
Process Connection			
Standard			Standard
A11 ⁽²⁾	Assemble to Rosemount 306 Integral Manifold		★
B11 ⁽²⁾⁽³⁾	Assemble to one Rosemount 1199 Seal		★
E11	1/2-14 NPT female		★
G11	G1/2 A DIN 16288 male (Range 1-4 only)		★
Expanded			
F11	Non-threaded instrument flange (I-flange) (Range 1-4 only)		
Transmitter Output			
Standard			Standard
A	4-20 mA with digital signal based on HART® protocol		★
F ⁽⁴⁾	FOUNDATION™ fieldbus protocol		★
X ⁽⁵⁾	Wireless (Requires wireless options and wireless PlantWeb housing)		★
Housing Style			
Standard			Standard
00	None (SuperModule spare part, order output code A)		★
1A	PlantWeb housing	Aluminum	1/2-14 NPT
1B	PlantWeb housing	Aluminum	M20 x 1.5
1J	PlantWeb housing	SST	1/2-14 NPT
1K	PlantWeb housing	SST	M20 x 1.5
5A ⁽¹⁶⁾	Wireless PlantWeb housing	Aluminum	1/2-14 NPT
5J ⁽¹⁶⁾	Wireless PlantWeb housing	SST	1/2-14 NPT
2A	Junction Box housing	Aluminum	1/2-14 NPT
2B	Junction Box housing	Aluminum	M20 x 1.5
2J	Junction Box housing	SST	1/2-14 NPT
2E	Junction Box Housing with output for remote display and interface	Aluminum	1/2-14 NPT
2F	Junction Box Housing with output for remote display and interface	Aluminum	M20 x 1.5
2M	Junction Box Housing with output for remote display and interface	SST	1/2-14 NPT
7J ⁽⁶⁾	Quick Connect (A size Mini, 4-pin male termination)	SST	

Rosemount 3051S Series

Table A-2. Rosemount 3051S Scalable In-Line Pressure Transmitter Ordering Information

★ The Standard offering represents the most common options. The starred options (★) should be selected for best delivery. The Expanded offering is subject to additional delivery lead time.

Expanded			
1C	PlantWeb housing	Aluminum	G ^{1/2}
1L	PlantWeb housing	SST	G ^{1/2}
2C	Junction Box housing	Aluminum	G ^{1/2}
2G	Junction Box Housing with output for remote display and interface	Aluminum	G ^{1/2}

Wireless Options (Requires option code X and wireless PlantWeb housing)

Update Rate		
Standard		
WA	User Configurable Update Rate	★
Operating Frequency and Protocol		
Standard		
3	2.4 GHz DSSS, IEC 62591 (WirelessHART)	★
Omnidirectional Wireless Antenna		
Standard		
WK	External Antenna	★
WM	Extended Range, External Antenna	★
SmartPower™		
Standard		
1 ⁽⁷⁾	Compatible with Black Power Module (I.S. Power Module Sold Separately)	★

Other Options (Include with selected model number)

PlantWeb Control Functionality		
Standard		
A01 ⁽⁸⁾	FOUNDATION fieldbus Advanced Control Function Block Suite	★
PlantWeb Diagnostic Functionality		
Standard		
D01 ⁽⁸⁾	FOUNDATION fieldbus Diagnostics Suite	★
DA2 ⁽⁸⁾⁽⁹⁾	Advanced HART Diagnostics Suite	★
Mounting Bracket⁽¹⁰⁾		
Standard		
B4	Bracket, all SST, 2-in. pipe and panel	★
Software Configuration		
Standard		
C1 ⁽¹¹⁾	Custom software configuration (Requires Configuration Data Sheet)	★
Alarm Limit		
Standard		
C4 ⁽⁸⁾⁽¹¹⁾	NAMUR alarm and saturation levels, high alarm	★
C5 ⁽⁸⁾⁽¹¹⁾	NAMUR alarm and saturation levels, low alarm	★
C6 ⁽⁸⁾⁽¹¹⁾	Custom alarm and saturation signal levels, high alarm (Requires C1 and Configuration Data Sheet)	★
C7 ⁽⁸⁾⁽¹¹⁾	Custom alarm and saturation signal levels, low alarm (Requires C1 and Configuration Data Sheet)	★
C8 ⁽⁸⁾⁽¹¹⁾	Low alarm (standard Rosemount alarm and saturation levels)	★
Hardware Adjustments		
Standard		
D1 ⁽⁸⁾⁽¹¹⁾⁽¹²⁾	Hardware adjustments (zero, span, alarm, security)	★
Custody Transfer		
Standard		
D3 ⁽¹³⁾	Measurement Canada Accuracy Approval	★
Ground Screw		
Standard		
D4	External ground screw assembly	★
Conduit Plug		
Standard		
DO ⁽¹⁴⁾	316 SST Conduit Plug	★

Table A-2. Rosemount 3051S Scalable In-Line Pressure Transmitter Ordering Information

★ The Standard offering represents the most common options. The starred options (★) should be selected for best delivery. The Expanded offering is subject to additional delivery lead time.

Product Certifications ⁽¹⁵⁾		
Standard		Standard
E1	ATEX Flameproof	★
I1	ATEX Intrinsic Safety	★
IA	ATEX FISCO Intrinsic Safety (FOUNDATION™ fieldbus protocol only)	★
N1	ATEX Type n	★
K1	ATEX Flameproof, Intrinsic Safety, Type n, Dust	★
ND	ATEX Dust	★
E4	TIIS Flameproof	★
I4 ⁽¹⁶⁾	TIIS Intrinsic Safety	★
E5	FM Explosion-proof, Dust Ignition-proof	★
I5	FM Intrinsically Safe, Division 2	★
IE	FM FISCO Intrinsically Safe (FOUNDATION™ fieldbus protocol only)	★
K5	FM Explosion-proof, Dust Ignition-proof, Intrinsically Safe, Division 2	★
E6 ⁽¹⁷⁾	CSA Explosion-proof, Dust Ignition-proof, Division 2	★
I6	CSA Intrinsically Safe	★
IF	CSA FISCO Intrinsically Safe (FOUNDATION™ fieldbus protocol only)	★
K6 ⁽¹⁷⁾	CSA Explosion-proof, Dust Ignition-proof, Intrinsically Safe, Division 2	★
E7	IECEX Flameproof, Dust Ignition-proof	★
I7	IECEX Intrinsic Safety	★
IG	IECEX FISCO Intrinsic Safety (FOUNDATION™ fieldbus protocol only)	★
N7	IECEX Type n	★
K7	IECEX Flameproof, Dust Ignition-proof, Intrinsic Safety, Type n	★
E2	INMETRO Flameproof	★
I2	INMETRO Intrinsic Safety	★
K2	INMETRO Flameproof, Intrinsic Safety	★
E3	China Flameproof	★
I3	China Intrinsic Safety	★
N3	China Type n	★
KA ⁽¹⁷⁾	ATEX and CSA Flameproof, Intrinsically Safe, Division 2	★
KB ⁽¹⁷⁾	FM and CSA Explosion-proof, Dust Ignition-proof, Intrinsically Safe, Division 2	★
KC	FM and ATEX Explosion-proof, Intrinsically Safe, Division 2	★
KD ⁽¹⁷⁾	FM, CSA, and ATEX Explosion-proof, Intrinsically Safe	★
Sensor Fill Fluid		
Standard		Standard
L1 ⁽¹⁸⁾	Inert sensor fill fluid	★
Display Type ⁽¹⁹⁾		
Standard		Standard
M5	PlantWeb LCD Display	★
M7 ⁽⁸⁾⁽²⁰⁾⁽²¹⁾	Remote mount LCD display and interface, PlantWeb housing, no cable, SST bracket	★
M8 ⁽⁸⁾⁽²⁰⁾	Remote mount LCD display and interface, PlantWeb housing, 50 ft. (15 m) cable, SST bracket	★
M9 ⁽⁸⁾⁽²⁰⁾	Remote mount LCD display and interface, PlantWeb housing, 100-ft. (31 m) cable, SST bracket	★
Pressure Testing		
Expanded		
P1	Hydrostatic testing with certificate	
Special Cleaning		
Expanded		
P2 ⁽¹⁰⁾	Cleaning for special services	
P3 ⁽¹⁰⁾	Cleaning for less than 1PPM chlorine/fluorine	
Calibration Certification		
Standard		Standard
Q4	Calibration certificate	★
QP	Calibration certificate and tamper evident seal	★
Material Traceability Certification		
Standard		Standard
Q8	Material traceability certification per EN 10204 3.1	★

Rosemount 3051S Series

Table A-2. Rosemount 3051S Scalable In-Line Pressure Transmitter Ordering Information

★ The Standard offering represents the most common options. The starred options (★) should be selected for best delivery. The Expanded offering is subject to additional delivery lead time.

Quality Certification for Safety		
Standard		Standard
QS ⁽⁸⁾⁽¹¹⁾	Prior-use certificate of FMEDA Data	★
QT ⁽²²⁾	Safety-certified to IEC 61508 with certificate of FMEDA data	★
Transient Protection		
Standard		Standard
T1 ⁽²³⁾⁽²⁴⁾	Transient terminal block	★
Drinking Water Approval		
Standard		Standard
DW ⁽²⁵⁾	NSF Drinking Water Approval	★
Surface Finish Certification		
Standard		Standard
Q16	Surface finish certification for sanitary remote seals	★
Toolkit Total System Performance Reports		
Standard		Standard
QZ	Remote Seal System Performance Calculation Report	★
Conduit Electrical Connector		
Standard		Standard
GE ⁽²⁶⁾	M12, 4-pin, Male Connector (eurofast [®])	★
GM ⁽²⁵⁾	A size Mini, 4-pin, Male Connector (minifast [®])	★
Typical Model Number: 3051S1TG 2A 2 E11 A 1A DA2 B4 M5		

- (1) Materials of Construction comply with metallurgical requirements highlighted within NACE MR0175/ISO 15156 for sour oil field production environments. Environmental limits apply to certain materials. Consult latest standard for details. Selected materials also conform to NACE MR0103 for sour refining environments.
- (2) "Assemble to" items are specified separately and require a completed model number.
- (3) Consult an Emerson Process Management representative for performance specifications.
- (4) Requires PlantWeb housing.
- (5) Available approvals are FM Intrinsically Safe, Division 2 (option code I5), CSA Intrinsically Safe (option code I6), ATEX Intrinsic Safety (option code I1), and IECEx Intrinsic Safety (option code I7).
- (6) Available with output code A only. Available approvals are FM Intrinsically Safe, Division 2 (option code I5), ATEX Intrinsic Safety (option code I1), or IECEx Intrinsic Safety (option code I7). Contact an Emerson Process Management representative for additional information.
- (7) Long-Life Power Module must be shipped separately, order Part #00753-9220-0001.
- (8) Not available with output code X.
- (9) Requires PlantWeb housing and output code A. Includes Hardware Adjustments as standard.
- (10) Not available with process connection option code A11.
- (11) Not available with output code F.
- (12) Not available with housing style codes 00, 01, 2E, 2F, 2G, 2M, 5A, 5J, or 7J.
- (13) Requires PlantWeb housing and Hardware Adjustments option code D1. Limited availability depending on transmitter type and range. Contact an Emerson Process Management representative for additional information.
- (14) Transmitter is shipped with 316 SST conduit plug (uninstalled) in place of standard carbon steel conduit plug.
- (15) Valid when SuperModule Platform and housing have equivalent approvals.
- (16) Only available with output code X.
- (17) Not available with M20 or G ½ conduit entry size.
- (18) Silicone fill fluid is standard.
- (19) Not available with Housing code 7J.
- (20) Not available with output code F, option code DA2, or option code QT.
- (21) See the 3051S Reference Manual (document number 00809-0100-4801) for cable requirements. Contact an Emerson Process Management representative for additional information.
- (22) Not available with output code F or X. Not available with housing code 7J.
- (23) Not available with Housing code 00, 5A, 5J, or 7J.
- (24) The T1 option is not needed with FISCO Product Certifications; transient protection is included in the FISCO product certification codes IA, IE, IF, and IG.
- (25) Requires 316L SST diaphragm material and Process Connection code E11 or G11.
- (26) Not available with Housing code 00, 5A, 5J, or 7J. Available with Intrinsically Safe approvals only. For FM Intrinsically Safe, Division 2 (option code I5) or FM FISCO Intrinsically Safe (option code IE), install in accordance with Rosemount drawing 03151-1009 to maintain outdoor rating (NEMA 4X and IP66).

Table A-3. Rosemount 3051S Liquid Level Transmitter Ordering Information

★ The Standard offering represents the most common options. The starred options (★) should be selected for best delivery.
The Expanded offering is subject to additional delivery lead time.

Model	Transmitter Type			
3051S	Liquid Level Transmitter			
Performance Class				
Standard				Standard
1	Ultra: 0.065% span accuracy, 100:1 rangedown, 12-year limited warranty			★
2	Classic: 0.065% span accuracy, 100:1 rangedown			★
Connection Type				
Standard				Standard
L	Level			★
Measurement Type				
Standard				Standard
D	Differential			★
G	Gage			★
A	Absolute			★
Pressure Range				
	Differential (LD)	Gage (LG)	Absolute (LA)	
Standard				Standard
2A	-250 to 250 inH ₂ O (-623 to 623 mbar)	-250 to 250 inH ₂ O (-623 to 623 mbar)	0 to 150 psia (10 bar)	★
3A	-1000 to 1000 inH ₂ O (-2,5 to 2,5 bar)	-393 to 1000 inH ₂ O (-0,98 to 2,5 bar)	0 to 800 psia (55 bar)	★
4A	-300 to 300 psi (-20,7 to 20,7 bar)	-14.2 to 300 psig (-0,98 to 21 bar)	0 to 4000 psia (276 bar)	★
5A	-2000 to 2000 psi (-137,9 to 137,9 bar)	-14.2 to 2000 psig (-0,98 to 137,9 bar)	N/A	★
Transmitter Output				
Standard				Standard
A	4-20 mA with digital signal based on HART protocol			★
F ⁽¹⁾	FOUNDATION fieldbus protocol			★
X ⁽²⁾	Wireless (Requires wireless options and wireless PlantWeb housing)			★
Housing Style		Material	Conduit Entry Size	
Standard				Standard
00	None (SuperModule spare part, order output code A)			★
1A	PlantWeb housing	Aluminum	1/2-14 NPT	★
1B	PlantWeb housing	Aluminum	M20 x 1.5	★
1J	PlantWeb housing	SST	1/2-14 NPT	★
1K	PlantWeb housing	SST	M20 x 1.5	★
2A	Junction Box housing	Aluminum	1/2-14 NPT	★
2B	Junction Box housing	Aluminum	M20 x 1.5	★
2E	Junction Box housing with output for remote interface	Aluminum	1/2-14 NPT	★
2F	Junction Box housing with output for remote interface	Aluminum	M20 x 1.5	★
2J	Junction Box housing	SST	1/2-14 NPT	★
2M	Junction Box housing with output for remote interface	SST	1/2-14 NPT	★
5A ⁽¹⁷⁾	Wireless PlantWeb housing	Aluminum	1/2-14 NPT	★
5J ⁽¹⁷⁾	Wireless PlantWeb housing	SST	1/2-14 NPT	★
7J ⁽³⁾	Quick Connect (A size Mini, 4-pin male termination)	SST		★
Expanded				
1C	PlantWeb housing	Aluminum	G 1/2	
1L	PlantWeb housing	SST	G 1/2	
2C	Junction Box housing	Aluminum	G 1/2	
2G	Junction Box housing with output for remote interface	Aluminum	G 1/2	

Rosemount 3051S Series

Table A-3. Rosemount 3051S Liquid Level Transmitter Ordering Information

★ The Standard offering represents the most common options. The starred options (★) should be selected for best delivery. The Expanded offering is subject to additional delivery lead time.

Seal System Type				
Standard				Standard
1	Direct-mount seal system			★
High Pressure Side Extension (Between Transmitter Flange and Seal)				
Standard				Standard
0	Direct-Mount (No Extension)			★
Sensor Module Configuration (Low Side)				
Standard				Standard
1 ⁽⁴⁾	Tuned-System Assembly, One Capillary Remote Seal (Requires 1199 model number, see Table A-3 of Rosemount DP Level PDS for seal information)			★
2	316L SST isolator / SST transmitter flange			★
3	Alloy C-276 isolator / SST transmitter flange			★
Capillary Length				
Standard				Standard
0	None			★
Seal Fill Fluid (High Side)		Temperature Limits (Ambient Temperature of 70° F (21° C))		
Standard				Standard
A	Syltherm XLT	-102 to 293 °F (-75 to 145 °C)		★
C	Silicone 704	32 to 401 °F (0 to 205 °C)		★
D	Silicone 200	-49 to 401 °F (-45 to 205 °C)		★
H	Inert (Halocarbon)	-49 to 320 °F (-45 to 160 °C)		★
G	Glycerine and Water	5 to 203 °F (-15 to 95 °C)		★
N	Neobee M-20	5 to 401 °F (-15 to 205 °C)		★
P	Propylene Glycol and Water	5 to 203 °F (-15 to 95 °C)		★
Process Connection Style				
Standard				Standard
FF	Flush Flanged Seal			★
EF	Extended Flanged Seal			★
Process Connection Size (High Side)				
	Flush Flanged Seal	Extended Flanged Seal		
Standard				Standard
G	2-in./DN 50	—		★
7	3-in.	3-in./DN 80, 2.58-in. diaphragm		★
J	DN 80	—		★
9	4-in./DN 100	4-in./DN 100, 3.5-in. diaphragm		★
Flange Rating (High Side)				
Standard				Standard
1	ANSI/ASME B16.5 Class 150			★
2	ANSI/ASME B16.5 Class 300			★
4	ANSI/ASME B16.5 Class 600			★
G	PN 40 per EN 1092-1			★
E	PN 10/16 per EN 1092-1, Available with DN 100 only			★
Isolator, Flange Material (High Side)				
	Flush Flanged Seal Isolator	Extended Flanged Seal Isolator and Wetted Parts	Flange Material	
Standard				Standard
CA	316L SST	316L SST	CS	★
DA	316L SST	316L SST	SST	★
CB	Alloy C-276	Alloy C-276	CS	★
DB	Alloy C-276	Alloy C-276	SST	★
CC	Tantalum - seam welded ⁽⁵⁾	—	CS	★
DC	Tantalum - seam welded ⁽⁵⁾	—	SST	★

Table A-3. Rosemount 3051S Liquid Level Transmitter Ordering Information

★ The Standard offering represents the most common options. The starred options (★) should be selected for best delivery.
The Expanded offering is subject to additional delivery lead time.

Lower Housing Material for FF, Extension Length for EF (High Side) ⁽⁶⁾			
	Flush Flanged Seal	Extended Flanged Seal	
Standard			Standard
0	None	—	★
2	—	2-in. (50 mm)	★
4	—	4-in. (100 mm)	★
6	—	6-in. (150 mm)	★
A	316 SST	—	★
B	Alloy C-276	—	★
D	Carbon Steel	—	★
Flushing Connection Quantity and Size (Lower Housing, High Side)			
	Flush Flanged Seal	Extended Flanged Seal	
Standard			Standard
0	None	None	★
1	1 (1/4 - 18 NPT)	—	★
3	2 (1/4 - 18 NPT)	—	★
7	1 (1/2 - 14 NPT)	—	★
9	2 (1/2 - 14 NPT)	—	★

Wireless Options (Requires option code X and wireless PlantWeb housing)

Update Rate			
Standard			Standard
WA	User Configurable Update Rate		★
Operating Frequency and Protocol			
Standard			Standard
3	2.4 GHz DSSS, IEC 62591 (WirelessHART)		★
Omnidirectional Wireless Antenna			
Standard			Standard
WK	External Antenna		★
WM	Extended Range, External Antenna		★
SmartPower™			
Standard			Standard
1 ⁽⁷⁾	Compatible with Black Power Module (I.S. Power Module Sold Separately)		★

Other Options (Include with selected model number)

Diaphragm Thickness			
Expanded			
SC	0.006-in. (150 µm) available with 316L SST and Alloy C-276		
Flushing Plug, Vent/Drain Valve			
Standard			Standard
SD	Alloy C-276 plug(s) for flushing connection(s)		★
SG	316 SST plug(s) for flushing connection(s)		★
SH	316 SST vent/drain for flushing connection(s)		★
Gasket Material			
Standard			Standard
SJ	PTFE gasket (for use with flushing connection ring)		★
Expanded			
SN	Grafoil® gasket (for use with flushing connection ring)		
Code Conformance			
Standard			Standard
ST ⁽⁸⁾	Wetted Materials Compliance to NACE MRO175/ISO 15156, MRO103		★

Rosemount 3051S Series

Table A-3. Rosemount 3051S Liquid Level Transmitter Ordering Information

★ The Standard offering represents the most common options. The starred options (★) should be selected for best delivery.
The Expanded offering is subject to additional delivery lead time.

PlantWeb Control Functionality		
Standard		Standard
A01 ⁽¹¹⁾	FOUNDATION fieldbus Advanced Control Function Block Suite	★
PlantWeb Diagnostic Functionality		
Standard		Standard
D01 ⁽¹¹⁾	FOUNDATION fieldbus Diagnostics Suite	★
DA2 ⁽⁹⁾⁽¹¹⁾	Advanced HART Diagnostics Suite	★
Software Configuration		
Standard		Standard
C1 ⁽¹⁰⁾	Custom software configuration (Requires Configuration Data Sheet)	★
Gage Pressure Calibration		
Standard		Standard
C3	Gage Pressure Calibration (3051SxLA4 only)	★
Alarm Limit		
Standard		Standard
C4 ⁽¹⁰⁾⁽¹¹⁾	NAMUR alarm and saturation levels, high alarm	★
C5 ⁽¹⁰⁾⁽¹¹⁾	NAMUR alarm and saturation levels, low alarm	★
C6 ⁽¹⁰⁾⁽¹¹⁾	Custom alarm and saturation signal levels, high alarm (Requires C1 and Configuration Data Sheet)	★
C7 ⁽¹⁰⁾⁽¹¹⁾	Custom alarm and saturation signal levels, low alarm (Requires C1 and Configuration Data Sheet)	★
C8 ⁽¹⁰⁾⁽¹¹⁾	Low alarm (standard Rosemount alarm and saturation levels)	★
Hardware Adjustments		
Standard		Standard
D1 ⁽¹⁰⁾⁽¹¹⁾⁽¹²⁾	Hardware adjustments (zero, span, alarm, security)	★
Flange Adapter		
Standard		Standard
D2	1/2-14 NPT flange adapter	★
Expanded		
D9	RC 1/2 SST flange adapter	
Custody Transfer		
Standard		Standard
D3 ⁽¹³⁾	Measurement Canada Accuracy Approval	★
Ground Screw		
Standard		Standard
D4	External ground screw assembly	★
Drain/Vent Valve		
Standard		Standard
D5	Delete transmitter drain/vent valves (install plugs)	★
Conduit Plug		
Standard		Standard
DO ⁽¹⁴⁾	316 SST Conduit Plug	★
Product Certifications⁽¹⁵⁾		
Standard		Standard
E1	ATEX Flameproof	★
E2	INMETRO Flameproof	★
E3	China Flameproof	★
E4	TIIS Flameproof	★
E5	FM Explosion-proof, Dust Ignition-proof	★
E6 ⁽¹⁶⁾	CSA Explosion-proof, Dust Ignition-proof, Division 2	★
E7	IECEX Flameproof, Dust Ignition-proof	★
I1	ATEX Intrinsic Safety	★
I2	INMETRO Intrinsic Safety	★
I3	China Intrinsic Safety	★
I4 ⁽¹⁷⁾	TIIS Intrinsic Safety	★

Table A-3. Rosemount 3051S Liquid Level Transmitter Ordering Information

★ The Standard offering represents the most common options. The starred options (★) should be selected for best delivery. The Expanded offering is subject to additional delivery lead time.

I5	FM Intrinsically Safe, Division 2	★
I6	CSA Intrinsically Safe	★
I7	IECEX Intrinsic Safety	★
IA	ATEX FISCO Intrinsic Safety (FOUNDATION fieldbus protocol only)	★
IE	FM FISCO Intrinsically Safe (FOUNDATION fieldbus protocol only)	★
IF	CSA FISCO Intrinsically Safe (FOUNDATION fieldbus protocol only)	★
IG	IECEX FISCO Intrinsic Safety (FOUNDATION fieldbus protocol only)	★
K1	ATEX Flameproof, Intrinsic Safety, Type n, Dust	★
K2	INMETRO Flameproof, Intrinsic Safety	★
K5	FM Explosion-proof, Dust Ignition-proof, Intrinsically Safe, Division 2	★
K6 ⁽¹⁶⁾	CSA Explosion-proof, Dust Ignition-proof, Intrinsically Safe, Division 2	★
K7	IECEX Flameproof, Dust Ignition-proof, Intrinsic Safety, Type n	★
KA ⁽¹⁶⁾	ATEX and CSA Flameproof, Intrinsically Safe, Division 2	★
KB ⁽¹⁶⁾	FM and CSA Explosion-proof, Dust Ignition-proof, Intrinsically Safe, Division 2	★
KC	FM and ATEX Explosion-proof, Intrinsically Safe, Division 2	★
KD ⁽¹⁶⁾	FM, CSA, and ATEX Explosion-proof, Intrinsically Safe	★
N1	ATEX Type n	★
N3	China Type n	★
N7	IECEX Type n	★
ND	ATEX Dust	★
Sensor Fill Fluid		
Standard		Standard
L1 ⁽¹⁸⁾	Inert sensor fill fluid	★
O-ring		
Standard		Standard
L2	Graphite-filled PTFE o-ring	★
Bolting Material		
Standard		Standard
L4	Austenitic 316 SST bolts	★
L5 ⁽⁶⁾	ASTM A193, Grade B7M bolts	★
L6	Alloy K-500 bolts	★
L7 ⁽⁸⁾	ASTM A453, Class D, Grade 660 bolts	★
L8	ASTM A193, Class 2, Grade B8M bolts	★
Display Type⁽¹⁹⁾		
Standard		Standard
M5	PlantWeb LCD Display	★
M7 ⁽¹¹⁾⁽²⁰⁾⁽²¹⁾	Remote mount LCD display and interface, PlantWeb housing, no cable, SST bracket	★
M8 ⁽¹¹⁾⁽²⁰⁾	Remote mount LCD display and interface, PlantWeb housing, 50 ft. (15 m) cable, SST bracket	★
M9 ⁽¹¹⁾⁽²⁰⁾	Remote mount LCD display and interface, PlantWeb housing, 100-ft. (31 m) cable, SST bracket	★
Pressure Testing		
Expanded		
P1	Hydrostatic testing with certificate	
Special Cleaning		
Expanded		
P2	Cleaning for special services	
P3	Cleaning for less than 1PPM chlorine/fluorine	
Calibration Certification		
Standard		Standard
Q4	Calibration certificate	★
QP	Calibration certificate and tamper evident seal	★

Rosemount 3051S Series

Table A-3. Rosemount 3051S Liquid Level Transmitter Ordering Information

★ The Standard offering represents the most common options. The starred options (★) should be selected for best delivery.
The Expanded offering is subject to additional delivery lead time.

Material Traceability Certification		
Standard		Standard
Q8	Material traceability certification per EN 10204 3.1	★
Quality Certification for Safety		
Standard		Standard
QS ⁽¹⁰⁾⁽¹¹⁾	Prior-use certificate of FMEDA data	★
QT ⁽²²⁾	Safety certified to IEC 61508 with certificate of FMEDA data	★
Transient Protection		
Standard		Standard
T1 ⁽²³⁾⁽²⁴⁾	Transient terminal block	★
Toolkit Total System Performance Reports		
Standard		Standard
QZ	Remote Seal System Performance Calculation Report	★
Conduit Electrical Connector		
Standard		Standard
GE ⁽²⁵⁾	M12, 4-pin, Male Connector (eurofast [®])	★
GM ⁽²⁵⁾	A size Mini, 4-pin, Male Connector (minifast [®])	★
Typical Model Number for EF seal: 3051S2LD 2A A 1A 1 0 2 0 D EF 7 1 DA 2 0		

- (1) Requires PlantWeb housing.
- (2) Available approvals are FM Intrinsically Safe, Division 2 (option code I5), CSA Intrinsically Safe (option code I6), ATEX Intrinsic Safety (option code I1), and IECEx Intrinsic Safety (option code I7).
- (3) Available with output code A only. Available approvals are FM Intrinsically Safe, Division 2 (option code I5), ATEX Intrinsic Safety (option code I1), or IECEx Intrinsic Safety (option code I7). Contact an Emerson Process Management representative for additional information.
- (4) With option code 1, user must select Seal Location option code M in Table A-3 of Rosemount DP Level PDS.
- (5) Not recommended for use with spiral wound metallic gaskets (see 1199 product data sheet, document 00813-0100-4016 for additional options).
- (6) Standard gasket for lower housing consists of non-asbestos fiber.
- (7) Long-life Power Module must be shipped separately, order Part No. 00753-9220-0001.
- (8) Materials of Construction comply with metallurgical requirements highlighted within NACE MR0175/ISO 15156 for sour oil field production environments. Environmental limits apply to certain materials. Consult latest standard for details. Selected materials also conform to NACE MR0103 for sour refining environments.
- (9) Requires PlantWeb housing and output code A. Includes Hardware Adjustments as standard.
- (10) Not available with output code F.
- (11) Not available with output code X.
- (12) Not available with housing style codes 00, 2E, 2F, 2G, 2M, 5A, 5J, or 7J.
- (13) Requires PlantWeb housing and Hardware Adjustments option code D1. Limited availability depending on transmitter type and range. Contact an Emerson Process Management representative for additional information.
- (14) Transmitter is shipped with 316 SST conduit plug (uninstalled) in place of standard carbon steel conduit plug.
- (15) Valid when SuperModule Platform and housing have equivalent approvals.
- (16) Not available with M20 or G ½ conduit entry size.
- (17) Only available with output code X.
- (18) Only available on differential and gage measurement types. Silicone fill fluid is standard.
- (19) Not available with Housing 7J.
- (20) Not available with output code F, option code DA2, or option code QT.
- (21) See the 3051S Reference Manual (document number 00809-0100-4801) for cable requirements. Contact an Emerson Process Management representative for additional information.
- (22) Not available with output code F or X. Not available with housing code 7J.
- (23) Not available with Housing code 00, 5A, 5J, or 7J.
- (24) The T1 option is not needed with FISCO Product Certifications; transient protection is included in the FISCO product certification codes IA, IE, IF, and IG.
- (25) Not available with Housing code 00, 5A, 5J, or 7J. Available with Intrinsically Safe approvals only. For FM Intrinsically Safe, Division 2 (option code I5) or FM FISCO Intrinsically Safe (option code IE), install in accordance with Rosemount drawing 03151-1009 to maintain outdoor rating (NEMA 4X and IP66).

Table A-4. Housing Kit for Rosemount 3051S Series Ordering Information

★ The Standard offering represents the most common options. The starred options (★) should be selected for best delivery.
The Expanded offering is subject to additional delivery lead time.

Model	Transmitter Type			
300S	Housing for 3051S Scalable Pressure Transmitter			
Code	Housing Style	Material	Conduit Entry Size	
Standard				Standard
1A	PlantWeb housing	Aluminum	1/2-14 NPT	★
1B	PlantWeb housing	Aluminum	M20 x 1.5	★
1J	PlantWeb housing	SST	1/2-14 NPT	★
1K	PlantWeb housing	SST	M20 x 1.5	★
2A	Junction Box housing	Aluminum	1/2-14 NPT	★
2B	Junction Box housing	Aluminum	M20 x 1.5	★
2E	Junction Box housing with output for remote interface	Aluminum	1/2-14 NPT	★
2F	Junction Box housing with output for remote interface	Aluminum	M20 x 1.5	★
2J	Junction Box housing	SST	1/2-14 NPT	★
2M	Junction Box housing with output for remote interface	SST	1/2-14 NPT	★
3A	Remote mount display and interface housing	Aluminum	1/2-14 NPT	★
3B	Remote mount display and interface housing	Aluminum	M20 x 1.5	★
3J	Remote mount display and interface housing	SST	1/2-14 NPT	★
7J ⁽¹⁾	Quick Connect (A size Mini, 4-pin male termination)	SST		★
Expanded				
1C	PlantWeb housing	Aluminum	G 1/2	
1L	PlantWeb housing	SST	G 1/2	
2C	Junction Box housing	Aluminum	G 1/2	
2G	Junction Box housing with output for remote interface	Aluminum	G 1/2	
3C	Remote mount display and interface housing	Aluminum	G 1/2	
Code	Transmitter Output			
Standard				Standard
A	4-20 mA with digital signal based on HART protocol			★
F ⁽²⁾	FOUNDATION fieldbus protocol			★

Options (Include with selected model number)

PlantWeb Control Functionality				
Standard				Standard
A01	FOUNDATION fieldbus Advanced Control Function Block Suite			★
PlantWeb Diagnostic Functionality				
Standard				Standard
D01	FOUNDATION fieldbus Diagnostics Suite			★
DA2 ⁽³⁾	Advanced HART Diagnostics Suite			★
Hardware Adjustments				
Standard				Standard
D1 ⁽⁴⁾	Hardware adjustments (zero, span, alarm, security) <i>Note: Not available with Housing Style codes 2E, 2F, 2G, 2M, 3A, 3B, 3C, 3J, or 7J.</i>			★
Conduit Plug				
Standard				Standard
DO	316 SST Conduit Plug			★
Product Certifications				
Standard				Standard
E1	ATEX Flameproof			★
I1	ATEX Intrinsic Safety			★
IA	ATEX FISCO Intrinsic Safety (FOUNDATION fieldbus protocol only)			★
N1	ATEX Type n			★
K1	ATEX Flameproof, Intrinsic Safety, Type n, Dust			★
ND	ATEX Dust			★
E5	FM Explosion-proof, Dust Ignition-proof			★
I5	FM Intrinsically Safe, Division 2			★
IE	FM FISCO Intrinsically Safe (FOUNDATION fieldbus protocol only)			★

Rosemount 3051S Series

Table A-4. Housing Kit for Rosemount 3051S Series Ordering Information

★ The Standard offering represents the most common options. The starred options (★) should be selected for best delivery.
The Expanded offering is subject to additional delivery lead time.

K5	FM Explosion-proof, Dust Ignition-proof, Intrinsically Safe, Division 2	★
E6	CSA Explosion-proof, Dust Ignition-proof, Division 2	★
I6	CSA Intrinsically Safe	★
IF	CSA FISCO Intrinsically Safe (FOUNDATION fieldbus protocol only)	★
K6	CSA Explosion-proof, Dust Ignition-proof, Intrinsically Safe, Division 2	★
E7	IECEX Flameproof, Dust Ignition-proof	★
I7	IECEX Intrinsic Safety	★
IG	IECEX FISCO Intrinsic Safety (FOUNDATION fieldbus protocol only)	★
N7	IECEX Type n	★
K7	IECEX Flameproof, Dust Ignition-proof, Intrinsic Safety, Type n	★
E2	INMETRO Flameproof	★
I2	INMETRO Intrinsic Safety	★
K2	INMETRO Flameproof, Intrinsic Safety	★
E3	China Flameproof	★
I3	China Intrinsic Safety	★
N3	China Type n	★
KA	ATEX and CSA Flameproof, Intrinsically Safe, Division 2 <i>Note: Only available on Housing Style codes IA, IJ, 2A, 2J, 2E, 2M, 3A, or 3J.</i>	★
KB	FM and CSA Explosion-proof, Dust Ignition-proof, Intrinsically Safe, Division 2 <i>Note: Only available on Housing Style codes IA, IJ, 2A, 2J, 2E, 2M, 3A, or 3J.</i>	★
KC	FM and ATEX Explosion-proof, Intrinsically Safe, Division 2 <i>Note: Only available on Housing Style codes IA, IJ, 2A, 2J, 2E, 2M, 3A, or 3J.</i>	★
KD	FM, CSA, and ATEX Explosion-proof, Intrinsically Safe <i>Note: Only available on Housing Style codes IA, IJ, 2A, 2J, 2E, 2M, 3A, or 3J.</i>	★
Display Type ⁽⁵⁾		
Standard		Standard
M5	PlantWeb LCD Display	★
M7 ⁽⁶⁾⁽⁷⁾	Remote mount LCD display and interface, PlantWeb housing, no cable, SST bracket	★
M8 ⁽⁷⁾	Remote mount LCD display and interface, SST bracket, 50 ft. (15 m) cable	★
M9 ⁽⁷⁾	Remote mount LCD display and interface, SST bracket, 100-ft. (31 m) cable	★
Transient Protection		
Standard		Standard
T1 ⁽⁸⁾	Transient terminal block	★
Conduit Electrical Connector		
Standard		Standard
GE ⁽⁹⁾	M12, 4-pin, Male Connector (<i>euromast</i> [®])	★
GM ⁽⁹⁾	A size Mini, 4-pin, Male Connector (<i>minifast</i> [®])	★
Typical Model Number: 300S 1A A E5		

- (1) Available with output code A only. Available approvals are FM Intrinsically Safe, Division 2 (option code I5), ATEX Intrinsic Safety (option code I1), or IECEx Intrinsic Safety (option code I7). Contact an Emerson Process Management representative for additional information.
- (2) Requires PlantWeb housing.
- (3) Requires PlantWeb housing and output code A. Includes Hardware Adjustments as standard.
- (4) Not available with output code F.
- (5) Not available with Housing code 7J.
- (6) See the 3051S Reference Manual (document number 00809-0100-4801) for cable requirements. Contact an Emerson Process Management representative for additional information.
- (7) Not available with output code F, or option code DA2. Only available on Housing Style codes 3A, 3B, 3C, or 3J.
- (8) Not available with Housing code 3A, 3B, 3C, 3J, or 7J.
- (9) Not available with Housing code 7J. Available with Intrinsically Safe approvals only. For FM Intrinsically Safe, Division 2 (option code I5) or FM FISCO Intrinsically Safe (option code IE), install in accordance with Rosemount drawing 03151-1009 to maintain outdoor rating (NEMA 4X and IP66).

EXPLODED VIEW DIAGRAM

The following drawing shows the name and location for commonly ordered spare parts.

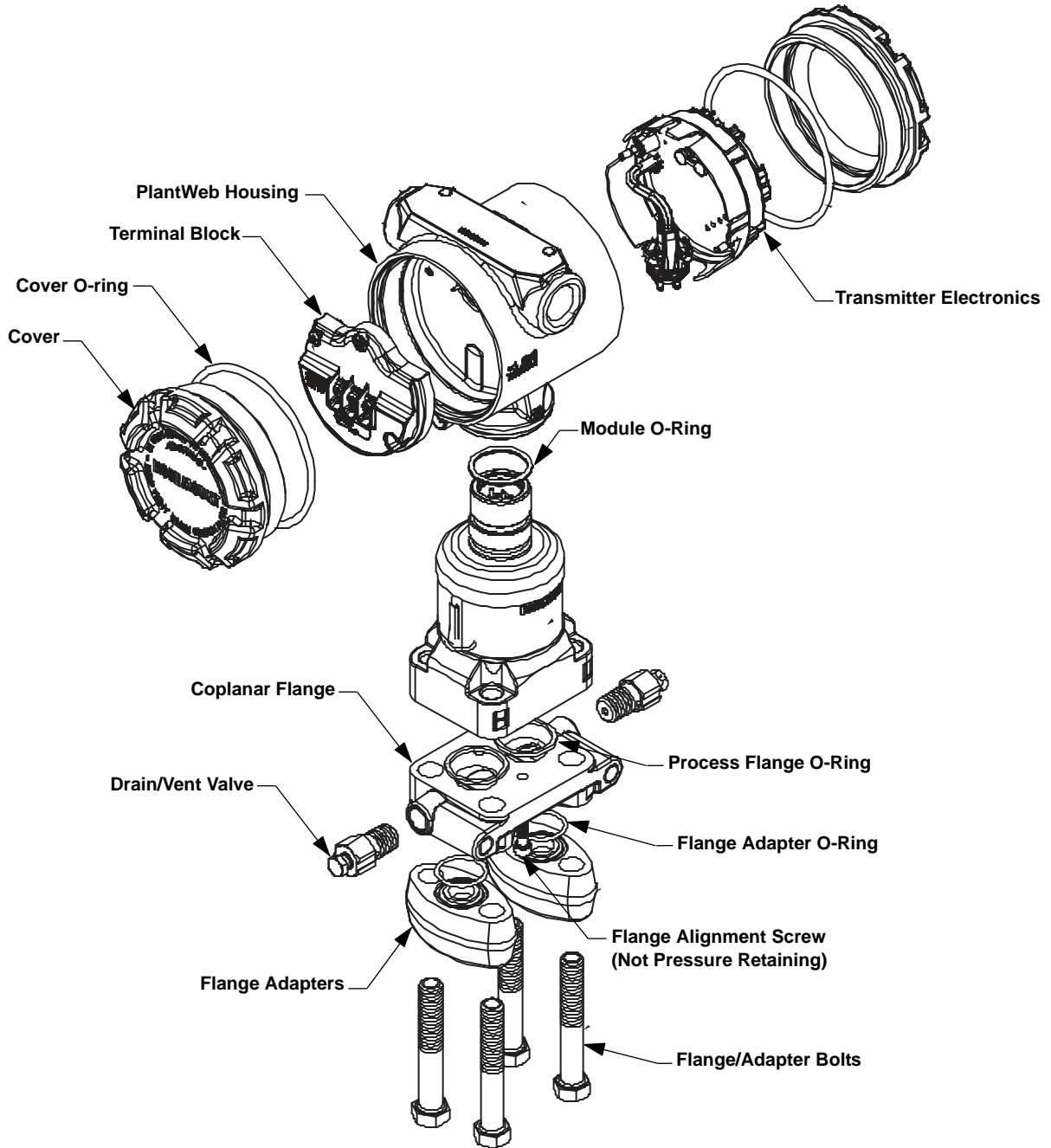

SPARE PARTS

See Rosemount 3051S_C, 3051S_T & 3051S_L ordering tables in Appendix A (A-23, A-29, and A-33 respectively) for ordering spare sensor modules.	
- Typical Model Number 3051S1CD2A2000A00	
Electronics Board Assembly Hardware (PlantWeb® Housing)	
LCD/Housing Interface Assemblies for Hart Output	
Standard Interface	03151-9010-0001
Hardware Adjustment Kit	03151-9015-0001
Adjustment Interface	
Adjustment Module	
Adjustment Interface	03151-9017-0001
Adjustment Module	03151-9019-0001
Remote Display Interface	03151-9023-0001
Remote Display and Interface Cable, 50 ft. (15 m)	03151-9101-0001
Remote Display and Interface Cable, 100 ft. (31 m)	03151-9101-0002
Fieldbus Output (Includes A01 and D01 PlantWeb Functionality)	
FOUNDATION™ Fieldbus Upgrade Kit (Standard)	03151-9021-0021
FOUNDATION Fieldbus Output Electronics	
Standard Dual Compartment Terminal Block	
FOUNDATION Fieldbus Upgrade Kit (with Transient Protection)	03151-9021-0022
FOUNDATION Fieldbus Output Electronics	
Transient Dual Compartment Terminal Block	
FOUNDATION Fieldbus Upgrade Kit (FISCO)	03151-9021-0023
FOUNDATION Fieldbus Output Electronics	
FISCO Dual Compartment Terminal Block	
FOUNDATION Fieldbus Output Electronics	03151-9020-0001
HART Diagnostics Electronics	
Advanced HART Diagnostics Upgrade Assembly	03151-9071-0001
Advanced HART Diagnostics Upgrade Assembly for SIS	03151-9071-0002
Advanced HART Diagnostics Replacement Assembly	03151-9071-0003
Miscellaneous	
PlantWeb housing header cable O-ring (package of 12)	03151-9011-0001
Electrical Housing, Terminal Blocks	
See Rosemount 300S Series Housing “Kit” in Appendix A, page A-39 for ordering spare housings.	
- Typical Model Number 300S1AAE5	
PlantWeb Housing Terminal Block, HART (4-20 mA)	
Standard Dual Compartment Terminal Block Assembly	03151-9005-0001
Transient Dual Compartment Terminal Block Assembly (Option T1)	03151-9005-0002
PlantWeb Housing Terminal Block, Fieldbus	
Standard Dual Compartment Terminal Block Assembly	03151-9005-0021
Transient Dual Compartment Terminal Block Assembly (Option T1)	03151-9005-0022
FISCO Dual Compartment Terminal Block Assembly	03151-9005-0023
Junction Box Terminal Block, HART (4-20 mA)	
Standard Junction Box Terminal Block Assembly	03151-9000-1001
Transient Junction Box Terminal Block Assembly (Option T1)	03151-9000-1002
Junction Box Terminal Block, HART (4-20 mA) with Adjustment	
Standard Junction Box Terminal Block Assembly, Switch	03151-9000-2001
Transient Junction Box Terminal Block Assembly, Switch (Option T1)	03151-9000-2002
Alarm/Security Jumper with O-ring	03151-9001-0001

Remote Meter Terminal Blocks	
PlantWeb Housing 7-Position Remote Communications Terminal Block Assembly	03151-9006-0101
Junction Box Remote Communications Standard Terminal Block Assembly	03151-9000-1010
Junction Box Remote Communications Transient Terminal Block Assembly	03151-9000-1011
Covers	
Aluminum Electronics Cover; Cover and O-ring	03151-9030-0001
316L SST Electronics Cover; Cover and O-ring	03151-9030-0002
Housing Miscellaneous	
External Ground Screw Assembly (Option D4): Screw, clamp, washer	03151-9060-0001
Housing V-Seal for both PlantWeb and Junction Box housings	03151-9061-0001
Flanges	
Part Number	
Differential Coplanar Flange	
Nickel-plated Carbon Steel	03151-9200-0025
316 SST	03151-9200-0022
Cast C-276	03151-9200-0023
Cast Alloy 400	03151-9200-0024
Gage/Absolute Coplanar Flange	
Nickel-plated Carbon Steel	03151-9200-1025
316 SST	03151-9200-1022
Cast C-276	03151-9200-1023
Cast Alloy 400	03151-9200-1024
Coplanar Flange Alignment Screw (package of 12)	03151-9202-0001
Traditional Flange	
316 SST	03151-9203-0002
Cast C-276	03151-9203-0003
Cast Alloy 400	03151-9203-0004
Level Flange, Vertical Mount	
2 in., Class 150, SST	03151-9205-0221
2 in., Class 300, SST	03151-9205-0222
3 in., Class 150, SST	03151-9205-0231
3 in., Class 300, SST	03151-9205-0232
DIN, DN 50, PN 40	03151-9205-1002
DIN, DN 80, PN 40	03151-9205-1012
Flange Adapter Kits (Each kit contains adapters, bolts, and O-ring for one DP transmitter or two GP/AP transmitters.)	
Differential Flange Adapter Kits	
CS Bolts, Glass Filled PTFE O-Rings	
SST Adapters	03031-1300-0002
Cast C-276 Adapters	03031-1300-0003
Cast Alloy 400 Adapters	03031-1300-0004
Ni Plated CS Adapters	03031-1300-0005
SST Bolts, Glass Filled PTFE O-Rings	
SST Adapters	03031-1300-0012
Cast C-276 Adapters	03031-1300-0013
Cast Alloy 400 Adapters	03031-1300-0014
Ni Plated CS Adapters	03031-1300-0015
CS Bolts, Graphite PTFE O-Rings	
SST Adapters	03031-1300-0102
Cast C-276 Adapters	03031-1300-0103

Rosemount 3051S Series

Cast Alloy 400 Adapters	03031-1300-0104
Ni Plated CS Adapters	03031-1300-0105
SST Bolts, Graphite PTFE O-Rings	
SST Adapters	03031-1300-0112
Cast C-276 Adapters	03031-1300-0113
Cast Alloy 400 Adapters	03031-1300-0114
Ni Plated CS Adapters	03031-1300-0115
Flange Adapter Union	Part Number
Nickel-plated Carbon Steel	03151-9259-0005
316 SST	03151-9259-0002
Cast C-276	03151-9259-0003
Cast Alloy 400	03151-9259-0004
Drain/Vent Valve Kits (each kit contains parts for one transmitter)	Part Number
Differential Drain/Vent Kits	
316 SST Valve Stem and Seat Kit	03151-9268-0022
Alloy C-276 Valve Stem and Seat Kit	03151-9268-0023
Alloy K-500 Valve Stem and Alloy 400 Seat Kit	03151-9268-0024
316 SST Ceramic Ball Drain/Vent Kit	03151-9258-0122
Alloy C-276 Ceramic Ball Drain/Vent Kit	03151-9268-0123
Alloy 400/K-500 Ceramic Ball Drain/Vent Kit	03151-9268-0124
Gage/Absolute Drain/Vent Kits	
316 SST Valve Stem and Seat Kit	03151-9268-0012
Alloy C-276 Valve Stem and Seat Kit	03151-9268-0013
Alloy K-500 Valve Stem and Alloy 400 Seat Kit	03151-9268-0014
316 SST Ceramic Ball Drain/Vent Kit	03151-9268-0112
Alloy C-276 Ceramic Ball Drain/Vent Kit	03151-9268-0113
Alloy 400/K-500 Ceramic Ball Drain/Vent Kit	03151-9268-0114
O-Ring Packages (package of 12)	
Electronic Housing, Cover (Standard and Meter)	03151-9040-0001
Electronics Housing, Module	03151-9041-0001
Process Flange, Glass-filled PTFE	03151-9042-0001
Process Flange, Graphite-filled PTFE	03151-9042-0002
Flange Adapter, Glass-filled PTFE	03151-9043-0001
Flange Adapter, Graphite-filled PTFE	03151-9043-0002
Gland and Collar Kits	
Gland and Collar Kits	03151-9250-0001
Mounting Brackets	
Coplanar Flange Bracket Kit	
B4 Bracket, SST, 2-in. pipe mount, SST bolts	03151-9270-0001
In-line Bracket Kit	
B4 Bracket, SST, 2-in. pipe mount, SST bolts	03151-9270-0002
Traditional Flange Bracket Kits	
B1 Bracket, 2-in. pipe mount, CS bolts	03151-9272-0001
B2 Bracket, panel mount, CS bolts	03151-9272-0002
B3 Flat Bracket for 2-in. pipe mount, CS bolts	03151-9272-0003
B7 (B1 style bracket with SST bolts)	03151-9272-0007
B8 (B2 style bracket with SST bolts)	03151-9272-0008
B9 (B3 style bracket with SST bolts)	03151-9272-0009
BA (SST B1 bracket with SST bolts)	03151-9272-0011
BC (SST B3 bracket with SST bolts)	03151-9272-0013

Bolt Kits	
COPLANAR FLANGE	
Flange Bolt Kit {44 mm (1.75 in.)}	
Carbon Steel (set of 4)	03151-9280-0001
316 SST (set of 4)	03151-9280-0002
ANSI/ASTM-A-193-B7M (set of 4)	03151-9280-0003
Alloy K-500 (set of 4)	03151-9280-0004
Flange/Adapter Bolt Kit {73 mm (2.88 in.)}	
Carbon Steel (set of 4)	03151-9281-0001
316 SST (set of 4)	03151-9281-0002
ANSI/ASTM-A-193-B7M (set of 4)	03151-9281-0003
Alloy K-500 (set of 4)	03151-9281-0004
Manifold/Flange Kit {57 mm (2.25 in.)}	
Carbon Steel (set of 4)	03151-9282-0001
316 SST (set of 4)	03151-9282-0002
ANSI/ASTM-A-193-B7M (set of 4)	03151-9282-0003
Alloy K-500 (set of 4)	03151-9282-0004
TRADITIONAL FLANGE	
Differential Flange and Adapter Bolt Kit	
Carbon Steel (set of 8)	03151-9283-0001
316 SST (set of 8)	03151-9283-0002
ANSI/ASTM-A-193-B7M (set of 8)	03151-9283-0003
Alloy K-500 (set of 8)	03151-9283-0004
Gage/Absolute Flange and Adapter Bolt Kit	
Carbon Steel (set of 6)	03151-9283-1001
316 SST (set of 6)	03151-9283-1002
ANSI/ASTM-A-193-B7M (set of 6)	03151-9283-1003
Alloy K-500 (set of 6)	03151-9283-1004
Manifold/Traditional Flange Bolts	
Carbon Steel	Use bolts supplied with manifold
316 SST	Use bolts supplied with manifold
LEVEL FLANGE, VERTICAL MOUNT	
Flange Bolt Kit (Each kit contains bolts for one transmitter)	
Carbon Steel (set of 4)	03151-9285-0001
316 SST (set of 4)	03151-9285-0002
Meters	Part Number
Indicating Meter for Plantweb Aluminum Housing	
Meter Kit: LCD assembly, 4-pin interconnection header and aluminum meter cover assembly	03151-9193-0001
Meter Only: LCD assembly, 4-pin interconnection header	03151-9193-0002
Cover Assembly Kit: aluminum meter cover assembly	03151-9193-0003
Indicating Meter for Plantweb 316L SST Housing	
Meter Kit: LCD assembly, 4-pin interconnection header, 316L SST meter cover assembly	03151-9193-0004
Meter Only: LCD assembly, 4-pin interconnection header	03151-9193-0002
Cover Assembly Kit: 316L SST meter cover assembly	03151-9193-0005

Rosemount 3051S Series

Reference Manual
00809-0100-4801, Rev FA
October 2010

Appendix B

Product Certifications

Approved Manufacturing Locations	page B-1
Ordinary Location Certification for FM	page B-1
Hazardous Locations Certifications	page B-2
Installation Drawings	page B-10

This section contains hazardous location certifications for 3051S HART protocol.

APPROVED MANUFACTURING LOCATIONS

- Rosemount Inc. — Chanhassen, Minnesota USA
- Emerson Process Management GmbH & Co. — Wessling, Germany
- Emerson Process Management Asia Pacific Private Limited — Singapore
- Beijing Rosemount Far East Instrument Co., LTD — Beijing, China
- Emerson Process Management LTDA — Sorocaba, Brazil
- Emerson Process Management (India) Pvt. Ltd. — Daman, India
- Emerson Process Management, Emerson FZE — Dubai, United Arab Emirates

ORDINARY LOCATION CERTIFICATION FOR FM

As standard, the transmitter has been examined and tested to determine that the design meets basic electrical, mechanical, and fire protection requirements by FM, a nationally recognized testing laboratory (NRTL) as accredited by the Federal Occupational Safety and Health Administration (OSHA).

European Directive Information

The EC declaration of conformity for all applicable European directives for this product can be found at www.rosemount.com. A hard copy may be obtained by contacting an Emerson Process Management representative.

ATEX Directive (94/9/EC)

Emerson Process Management complies with the ATEX Directive.

European Pressure Equipment Directive (PED) (97/23/EC)

Models 3051S_CA4; 3051S_CD2, 3, 4, 5; (also with P9 option) Pressure Transmitters — QS Certificate of Assessment -

EC No. 59552-2009-CE-HOU-DNV, Module H Conformity Assessment

All other Model 3051S Pressure Transmitters
— Sound Engineering Practice

Transmitter Attachments: Diaphragm Seal - Process Flange - Manifold — Sound Engineering Practice

Primary Elements, Flowmeter
— See appropriate Primary Element QIG

Electro Magnetic Compatibility (EMC) (2004/108/EC)

EN 61326-1:2006
EN 61326-2-3:2006

Radio and Telecommunications Terminal Equipment Directive (R&TTE)(1999/5/EC)

Emerson Process Management complies with the R&TTE Directive.

Rosemount 3051S Series

HAZARDOUS LOCATIONS CERTIFICATIONS

North American Certifications

FM Approvals

- E5** Explosion-proof for Class I, Division 1, Groups B, C, and D, T5 ($T_a = 85\text{ }^\circ\text{C}$); Dust Ignition-proof for Class II and Class III, Division 1, Groups E, F, and G, T5 ($T_a = 85\text{ }^\circ\text{C}$); hazardous locations; enclosure Type 4X, conduit seal not required when installed according to Rosemount drawing 03151-1003.
- I5/IE** Intrinsically Safe for use in Class I, Division 1, Groups A, B, C, and D, T4 ($T_a = 70\text{ }^\circ\text{C}$ for output options A or X; $T_a = 60\text{ }^\circ\text{C}$ for output option F); Class II, Division 1, Groups E, F, and G; Class III, Division 1; Class I, Zone 0 AEx ia IIC T4 ($T_a = 70\text{ }^\circ\text{C}$ for output options A or X; $T_a = 60\text{ }^\circ\text{C}$ for output option F) when connected in accordance with Rosemount drawing 03151-1006; Non-Incendive for Class I, Division 2, Groups A, B, C, and D; T4 ($T_a = 70\text{ }^\circ\text{C}$ for output options A or X; $T_a = 60\text{ }^\circ\text{C}$ for output option F) Enclosure Type 4X
For entity parameters see control drawing 03151-1006.

Canadian Standards Association (CSA)

All CSA hazardous approved transmitters are certified per ANSI/ISA 12.27.01-2003.

- E6** Explosion-proof for Class I, Division 1, Groups B, C, and D; Dust Ignition-proof for Class II and Class III, Division 1, Groups E, F, and G; suitable for Class I, Division 2, Groups A, B, C, and D, when installed per Rosemount drawing 03151-1013, CSA Enclosure Type 4X; conduit seal not required; Dual Seal.
- I6/IF** Intrinsically Safe for Class I, Division 1, Groups A, B, C, and D when connected in accordance with Rosemount drawings 03151-1016; Dual Seal.
For entity parameters see control drawing 03151-1016.

European Certifications

I1/IA ATEX Intrinsic Safety

Certificate No.: BAS01ATEX1303X  II 1G

Ex ia IIC T4 ($T_a = -60\text{ }^\circ\text{C}$ to $70\text{ }^\circ\text{C}$) -HART/Remote Display/Quick Connect/HART Diagnostics

Ex ia IIC T4 ($T_a = -60\text{ }^\circ\text{C}$ to $70\text{ }^\circ\text{C}$) -FOUNDATION fieldbus

Ex ia IIC T4 ($T_a = -60\text{ }^\circ\text{C}$ to $40\text{ }^\circ\text{C}$) -FISCO

CE 1180

Input Parameters

Loop / Power	Groups
$U_i = 30\text{ V}$	HART / FOUNDATION fieldbus/ Remote Display / Quick Connect / HART Diagnostics
$U_i = 17.5\text{ V}$	FISCO
$I_i = 300\text{ mA}$	HART / FOUNDATION fieldbus/ Remote Display / Quick Connect / HART Diagnostics
$I_i = 380\text{ mA}$	FISCO
$P_i = 1.0\text{ W}$	HART / Remote Display / Quick Connect / HART Diagnostics
$P_i = 1.3\text{ W}$	FOUNDATION fieldbus
$P_i = 5.32\text{ W}$	FISCO
$C_i = 30\text{ nF}$	SuperModule Platform
$C_i = 11.4\text{ nF}$	HART / HART Diagnostics / Quick Connect
$C_i = 0$	FOUNDATION fieldbus / Remote Display / FISCO
$L_i = 0$	HART / FOUNDATION fieldbus/ FISCO / Quick Connect / HART Diagnostics
$L_i = 60\text{ }\mu\text{H}$	Remote Display
RTD Assembly (3051SFx Option T or R)	
$U_i = 5\text{ Vdc}$	
$I_i = 500\text{ mA}$	
$P_i = 0.63\text{ W}$	

Special conditions for safe use (x)

1. The apparatus, excluding the Types 3051 S-T and 3051 S-C (In-line and Coplanar SuperModule Platforms respectively), is not capable of withstanding the 500V test as defined in Clause 6.3.12 of EN 60079-11. This must be considered during installation.
2. The terminal pins of the Types 3051 S-T and 3051 S-C must be protected to IP20 minimum.

N1 ATEX Type n
Certificate No.: BAS01ATEX3304X  II 3 G
Ex nL IIC T4 ($T_a = -40\text{ °C TO }70\text{ °C}$)
Ui = 45 Vdc max
Ci = 11.4 nF (Transmitter Output Option A)
Ci = 0 (Transmitter Output Option F)
Li = 0
For remote display, Ci = 0, Li = 60 μ H
IP66
CE

Special conditions for safe use (x)

The apparatus is not capable of withstanding the 500V insulation test required by Clause 6.8.1 of EN 60079-15.
This must be taken into account when installing the apparatus.

NOTE

RTD Assembly is not included with the 3051SFx Type n Approval.

ND ATEX Dust
Certificate No.: BAS01ATEX1374X  II 1 D
Ex tD A20 T 105 °C ($-20\text{ °C} \leq T_{amb} \leq 85\text{ °C}$)
 $V_{max} = 42.4$ volts max
A = 22 mA
IP66
CE 1180

Special conditions for safe use (x)

1. Cable entries must be used which maintain the ingress protection of the enclosure to at least IP66.
2. Unused cable entries must be filled with suitable blanking plugs which maintain the ingress protection of the enclosure to at least IP66.
3. Cable entries and blanking plugs must be suitable for the ambient range of the apparatus and capable of withstanding a 7J impact test.
4. The 3051S must be securely screwed in place to maintain the ingress protection of the enclosure. (The 3051S SuperModule must be properly assembled to the 3051S housing to maintain ingress protection.)

E1 ATEX Flameproof
Certificate No.: KEMA00ATEX2143X  II 1/2 G
Ex d IIC T6 ($-50\text{ °C} \leq T_{amb} \leq 65\text{ °C}$)
Ex d IIC T5 ($-50\text{ °C} \leq T_{amb} \leq 80\text{ °C}$)
 $V_{max} = 42.4$ V
CE 1180

Special conditions for safe use (x)

1. Appropriate ex d blanking plugs, cable glands, and wiring needs to be suitable for a temperature of 90 °C.
2. This device contains a thin wall diaphragm. Installation, maintenance and use shall take into account the environmental conditions to which the diaphragm will be subjected. The manufacturer's instructions for maintenance shall be followed in detail to assure safety during its expected lifetime.
3. The 3051S does not comply with the requirements of EN 60079-1 Clause 5.2, Table 2 for all joints. Contact Emerson Process Management for information on the dimensions of flameproof joints.

Japanese Certifications

E4 TIIS Flameproof
Ex d IIC T6

Certificate	Description
TC15682	Coplanar with Junction Box Housing
TC15683	Coplanar with PlantWeb Housing
TC15684	Coplanar with PlantWeb Housing and LCD Display
TC15685	In-Line SST with Junction Box Housing
TC15686	In-Line Alloy C-276 with Junction Box Housing
TC15687	In-Line SST with PlantWeb Housing
TC15688	In-Line Alloy C-276 with PlantWeb Housing
TC15689	In-Line SST with PlantWeb Housing and LCD Display
TC15690	In-Line Alloy C-276 with PlantWeb Housing and LCD Display
TC17102	Remote Display
TC17099	3051SFA/C/P SST/Alloy C-276 with PlantWeb Housing and LCD Display
TC17100	3051SFA/C/P SST/Alloy C-276 with PlantWeb Housing and Remote Display
TC17101	3051SFA/C/P SST/Alloy C-276 with Junction Box Housing

China (NEPSI) Certifications

E3 China Flameproof, Dust Ignition-proof
 Certificate No. (manufactured in Chanhassen, MN): GYJ091035
 Certificate No. (manufactured in Beijing, China): GYJ06366
 Certificate No. (manufactured in Singapore): GYJ06364
 Certificate No. (3051SFx RTC, BMMC, SMMC): GYJ071086
 Ex d IIB+H₂ T3~T5
 DIP A21 T_A T3~T5 IP66

Special conditions for safe use

- Only the pressure transmitters, consisting of the 3051SC Series, 3051ST Series, 3051SL Series, and the 300S Series, are certified.
- Applicable ambient temperature range: -20 to 60 °C.
- The temperature class depends on the temperature of process medium:

Temperature Class	Temperature of Process Medium
T5	≤ 95 °C
T4	≤ 130 °C
T3	≤ 190 °C

- The earth connection in the enclosure should be connected reliably.
- During installation, use, and maintenance of the pressure transmitter, observe the warning, "Don't open the cover when the circuit is alive."
- There should be no corrosive gases present that could damage the flameproof housing.
- A cable entry, certified by NEPSI with type of protection Ex d IIC in accordance with GB3836.1-2000 and GB3836.2-2000, should be used when installing in a hazardous location. Five full threads should be engaged when the cable entry is assembled to the pressure transmitter.
- The diameter of the cable should meet the requirements of the cable entry instruction manual. The compression nut should be tightened. Aged seal rings should be replaced.
- Maintenance should not be performed if the location is hazardous.
- End users are not permitted to change internal components.

11. During installation, use, and maintenance of the pressure transmitter, observe the following standards:
 - a. GB3836.13-1997 "Electrical apparatus for explosive gas atmospheres Part 13: Repair and overhaul for apparatus used in explosive gas atmospheres"
 - b. GB3836.15-2000 "Electrical apparatus for explosive gas atmospheres Part 15: Electrical installations in hazardous area (other than mines)" GB50257-1996 "Code for construction and acceptance of electric device for explosion atmospheres and fire hazard electrical equipment installation engineering"

I3 China Intrinsic Safety, Dust Ignition-proof
 Certificate No. (manufactured in Chanhassen, MN): GYJ081078
 Certificate No. (manufactured in Beijing, China): GYJ06367
 Certificate No. (manufactured in Singapore): GYJ06365
 Certificate No. (3051SFx RTC, BMMC, SMMC): GYJ071293
 Ex ia IIC T4
 DIP A21 T_A T4 IP66

Special conditions for safe use

1. Only the pressure transmitters, consisting of the 3051SC Series, 3051ST Series, 3051SL Series, and the 300S Series, are certified.
2. Applicable ambient temperature range: -60 °C to 70 °C.
3. For explosive gas atmospheres:

Input Parameters

Loop / Power	Groups
U _i = 30 V	HART / FOUNDATION fieldbus/ Remote Display / Quick Connect / HART Diagnostics
I _i = 300 mA	HART / FOUNDATION fieldbus/ Remote Display / Quick Connect / HART Diagnostics
P _i = 1.0 W	HART / Remote Display / Quick Connect / HART Diagnostics
P _i = 1.3 W	FOUNDATION fieldbus
C _i = 38 nF	SuperModule Platform
C _i = 11.4 nF	HART / HART Diagnostics / Quick Connect
C _i = 0	FOUNDATION fieldbus / Remote Display
L _i = 0	SuperModule Platform
L _i = 2.4 μH	HART / FOUNDATION fieldbus / Quick Connect / HART Diagnostics
L _i = 58.2 μH	Remote Display
RTD Assembly (3051SFx Option T or R)	
U _i = 5 Vdc	
I _i = 500 mA	
P _i = 0.63W	

4. During installation, protective measures should be taken to ensure ingress protection is IP20 (GB4208) minimum.
5. The cable between the pressure transmitter and associated apparatus should be 2-wire, insulated, shielded cable. The cable core section area should be greater than 0.5 mm². The cable shield must be grounded in a non-hazardous area and isolated from the housing. The wiring should not be affected by electromagnetic disturbance.
6. The associated apparatus should be installed in a safe location. During installation, operation, and maintenance, the requirements per the instruction manual should be strictly observed.
7. End users are not permitted to change internal components.

8. During installation, use, and maintenance of the pressure transmitter, observe the following standards:
- a. GB3836.13-1997 "Electrical apparatus for explosive gas atmospheres Part 13: Repair and overhaul for apparatus used in explosive gas atmospheres"
 - b. GB3836.15-2000 "Electrical apparatus for explosive gas atmospheres Part 15: Electrical installations in hazardous area (other than mines)"
 - c. GB3836.16-2006 "Electrical apparatus for explosive gas atmospheres Part 16: Inspection and maintenance of electrical installation (other than mines)"
 - d. GB50257-1996 "Code for construction and acceptance of electric device for explosion atmospheres and fire hazard electrical equipment installation engineering"

N3 China Type n - Energy Limited
Certificate No.: GYJ101112X
Ex nL IIC T5 (-40 °C ≤ Ta ≤ 70 °C)
IP66

Loop / Power	Transmitter Output
U _i = 30 V	HART / FOUNDATION fieldbus
I _i = 300 mA	HART / FOUNDATION fieldbus
P _i = 1.0 W	HART
P _i = 1.3 W	FOUNDATION fieldbus
C _i = 11.4 nF	HART
C _i = 0 nF	FOUNDATION fieldbus
L _i = 0 μH	HART ⁽¹⁾ / FOUNDATION fieldbus

(1) For remote meter option (M7, M8, M9), L_i = 60 μH.

Special conditions for safe use (x)

1. The apparatus is not capable of withstanding the 500V test to earth for one minute. This must be taken into consideration during installation.
2. The ambient temperature range of the device is: -40 °C ≤ Ta ≤ 70 °C
3. Cable glands, conduit or blanking plugs, certified by NEPSI with Ex e or Ex n protection type and IP66 degree of protection provided by enclosure should be used on external connections and redundant cable entries.
4. See the Table for the input parameters for the energy limited transmitter.
5. The product should be used with an associated energy-limited apparatus certified by NEPSI in accordance with GB3836.1-2000 and GB3836.8-2003 to establish an explosion protection system that can be used in explosive gas atmospheres.
6. The cables between this product and associated energy-limited apparatus should be shielded cables (the cables must have an insulated shield). The shield has to be grounded reliably in the non-hazardous area.
7. Maintenance should be done in non-hazardous locations.
8. End users are not permitted to change internal components.
9. During installation, use, and maintenance of the pressure transmitter, observe the following standards:
 - a. GB3836.13-1997 "Electrical apparatus for explosive gas atmospheres Part 13: Repair and overhaul for apparatus used in explosive gas atmospheres"
 - b. GB3836.15-2000 "Electrical apparatus for explosive gas atmospheres Part 15: Electrical installations in hazardous area (other than mines)"
 - c. GB3836.16-2006 "Electrical apparatus for explosive gas atmospheres Part 16: Inspection and maintenance of electrical installation (other than mines)"
 - d. GB50257-1996 "Code for construction and acceptance of electric device for explosion atmospheres and fire hazard electrical equipment installation engineering"

INMETRO Certifications

- I2** Brazilian Approval (INMETRO Approval) - Intrinsic Safety
Certificate number: CEPEL-EX-0722/05X
(manufacturing in Chanhassen, MN and Singapore)
Certificate number: CEPEL-EX-1414/07X
(manufacturing in Brazil)
INMETRO Marking: BR-Ex ia IIC T4 IP66W

Special conditions for safe use (x)

The apparatus, excluding the Types 3051S-T and 3051S-C (In-line and Coplanar SuperModule Platforms respectively), is not capable of withstanding the 500V test as defined in Clause 6.3.12 of IEC60079-11. This must be considered during installation.

- E2** Brazilian Approval (INMETRO Approval) - Flameproof
Certificate number: CEPEL-EX-140/2003X
(manufacturing in Chanhassen, MN and Singapore)
Certificate number: CEPEL-EX-1413/07X
(manufacturing in Brazil)
INMETRO Marking: BR-Ex d IIC T5/T6 IP66W

Special conditions for safe use (x)

1. This device contains a thin wall diaphragm. Installation, maintenance, and use shall take into account the environmental conditions to which the diaphragm will be subjected. The manufacturer's instructions for installation and maintenance shall be followed in detail to assure safety during its expected lifetime.
2. For ambient temperature above 60 °C, cable wiring must have minimum isolation temperature of 90 °C, to be in accordance to equipment operation temperature.
3. The accessory of cable entries or conduit must be certified as flameproof and needs to be suitable for use conditions.
4. Where electrical entry is via conduit, the required sealing device must be assembled immediately close to enclosure.

IECEx Certifications

- E7** IECEx Flameproof and Dust (each listed separately)

IECEx Flameproof
Certificate No.: IECExKEM08.0010X
Ex d IIC T6 (-50 °C ≤ T_{amb} ≤ 65 °C)
Ex d IIC T5 (-50 °C ≤ T_{amb} ≤ 80 °C)
V_{max} = 42.4V

Special conditions for safe use (x)

1. Appropriate ex d blanking plugs, cable glands, and wiring needs to be suitable for a temperature of 90 °C.
2. This device contains a thin wall diaphragm. Installation, maintenance and use shall take into account the environmental conditions to which the diaphragm will be subjected. The manufacturer's instructions for maintenance shall be followed in detail to assure safety during its expected lifetime.
3. The 3051S does not comply with the requirements of IEC 60079-1 Clause 5.2, Table 2 for all joints. Contact Emerson Process Management for information on the dimensions of flameproof joints.

IECEX Dust
Certificate No. IECEXBAS09.0014X
Ex tD A20 T105°C (-20 °C ≤ T_{amb} ≤ 85 °C)
V_{max} = 42.4 V
A = 22 mA
IP66

Special conditions for safe use (x)

1. Cable entries must be used which maintain the ingress protection of the enclosure to at least IP66.
2. Unused cable entries must be filled with suitable blanking plugs which maintain the ingress protection of the enclosure to at least IP66.
3. Cable entries and blanking plugs must be suitable for the ambient range of the apparatus and capable of withstanding a 7J impact test.
4. The 3051S must be securely screwed in place to maintain the ingress protection of the enclosure. (The 3051S SuperModule must be properly assembled to the 3051S housing to maintain ingress protection.)

I7/IG IECEX Intrinsic Safety

Certificate No.: IECEXBAS04.0017X
Ex ia IIC T4 (T_a = -60 °C to 70 °C) -HART/Remote Display/Quick Connect/HART Diagnostics
Ex ia IIC T4 (T_a = -60 °C to 70 °C) -FOUNDATION fieldbus
Ex ia IIC T4 (T_a = -60 °C to 40 °C) -FISCO
IP66

Input Parameters

Loop / Power	Groups
U _i = 30 V	HART / FOUNDATION fieldbus/ Remote Display / Quick Connect / HART Diagnostics
U _i = 17.5 V	FISCO
I _i = 300 mA	HART / FOUNDATION fieldbus/ Remote Display / Quick Connect / HART Diagnostics
I _i = 380 mA	FISCO
P _i = 1.0 W	HART / Remote Display / Quick Connect / HART Diagnostics
P _i = 1.3 W	FOUNDATION fieldbus
P _i = 5.32 W	FISCO
C _i = 30 nF	SuperModule Platform
C _i = 11.4 nF	HART / HART Diagnostics / Quick Connect
C _i = 0	FOUNDATION fieldbus / Remote Display / FISCO
L _i = 0	HART / FOUNDATION fieldbus/ FISCO / Quick Connect / HART Diagnostics
L _i = 60 μH	Remote Display
RTD Assembly (3051SFx Option T or R)	
U _i = 5 Vdc	
I _i = 500 mA	
P _i = 0.63 W	

Special conditions for safe use (x)

1. The 3051S HART 4-20 mA, 3051S FOUNDATION fieldbus, 3051S Profibus and 3051S FISCO are not capable of withstanding the 500V test as defined in clause 6.3.12 of IEC 60079-11. This must be taken into account during installation.
2. The terminal pins of the Types 3051S-T and 3051S-C must be protected to IP20 minimum.

- N7** IECEx Type n
Certificate No.: IECExBAS04.0018X
Ex nC IIC T4 ($T_a = -40\text{ }^\circ\text{C}$ to $70\text{ }^\circ\text{C}$)
 $U_i = 45\text{ Vdc MAX}$
IP66
Special conditions for safe use (x)
The apparatus is not capable of withstanding the 500 V insulation test required by Clause 8 of IEC 60079-15.

Combinations of Certifications

Stainless steel certification tag is provided when optional approval is specified. Once a device labeled with multiple approval types is installed, it should not be reinstalled using any other approval types. Permanently mark the approval label to distinguish it from unused approval types.

- K1** Combination of E1, I1, N1, and ND
K2 Combination of E2 and I2
K5 Combination of E5 and I5
K6 Combination of E6 and I6
K7 Combination of E7, I7, and N7
KA Combination of E1, I1, E6, and I6
KB Combination of E5, I5, I6 and E6
KC Combination of E5, E1, I5 and I1
KD Combination of E5, I5, E6, I6, E1, and I1

Rosemount 3051S Series

INSTALLATION DRAWINGS

Factory Mutual (FM)

CONFIDENTIAL AND PROPRIETARY INFORMATION IS CONTAINED HEREIN AND MUST BE HANDLED ACCORDINGLY.	REVISIONS					
	ZONE	REV	DESCRIPTION	CHG. NO.	APP'D	DATE
		AA	NEW RELEASE	RTC1009618	P.C.S.	9/11/00
		AB	ADD 3051S_L AND TRADITIONAL HOUSING	RTC1015145	B.L.H.	4/7/03
		AC	UPDATE DRAWING	RTC1030895	A.J.W.	5/12/10

NOTES:

1. WIRING METHOD SUITABLE FOR CLASS I, DIV 1 or CLASS I, ZONE 1 WITH ANY LENGTH.
2. TRANSMITTER MUST NOT BE CONNECTED TO EQUIPMENT GENERATING MORE THAN 250 VAC.
3. ALL CONDUIT THREADS TO BE ASSEMBLED WITH FIVE FULL THREADS MINIMUM.
4. COMPONENTS REQUIRED TO BE APPROVED MUST BE APPROVED FOR GAS GROUP APPROPRIATE TO AREA CLASSIFICATION.
5. 3051S SERIES SENSOR MODULE MUST BE INSTALLED WITH FM FLAMEPROOF / EXPLOSIONPROOF APPROVED 300S SERIES HOUSING ATTACHED TO MEET FLAMEPROOF / EXPLOSIONPROOF INSTALLATION REQUIREMENTS.
6. INSTALLATION TO BE IN ACCORDANCE WITH THE LATEST EDITION OF NATIONAL ELECTRICAL CODE (NFPA 70).
7. 300S SERIES HOUSING MUST BE INSTALLED WITH FM FLAMEPROOF / EXPLOSIONPROOF APPROVED 3051S SERIES SENSOR MODULE ATTACHED TO MEET FLAMEPROOF / EXPLOSIONPROOF INSTALLATION REQUIREMENTS.
8. UNUSED CONDUIT ENTRY MUST BE CLOSED WITH SUITABLE BLANKING ELEMENT.

CAD Maintained, (Pro/E)

<small>UNLESS OTHERWISE SPECIFIED DIMENSIONS IN INCHES (mm). REMOVE ALL BURRS AND SHARP EDGES. MACHINE SURFACE FINISH 125</small> -TOLERANCES- .X ± .1 (2.5) .XX ± .02 (0.5) .XXX ± .010 (0.25) FRACTIONS ANGLES ± 1/32 ± 2° DO NOT SCALE PRINT	CONTRACT NO.		 ROSEMOUNT® <small>8200 Market Boulevard • Chanhassen, MN 55317 USA</small>			
	DR. <i>Myles Lee Miller</i>	8/28/00	TITLE MODEL 3051 / 300 EXPLOSIONPROOF / FLAMEPROOF INSTALLATION DRAWING, FM			
	CHK'D					
	APP'D <i>Baul C. Sundet</i>	9/11/00	SIZE A	FSCM NO.	DRAWING NO. 03151-1003	
APP'D GOVT.		SCALE 1 : 4	WT.	SHEET 1	OF 3	

REVISIONS					
ZONE	REV	DESCRIPTION	CHG. NO.	APP'D	DATE
	AC				

COMPONENT IDENTIFICATION

300S SERIES PLANTWEB
 (DUAL COMPARTMENT HOUSING)

300S SERIES JUNCTION BOX
 (SINGLE COMPARTMENT)

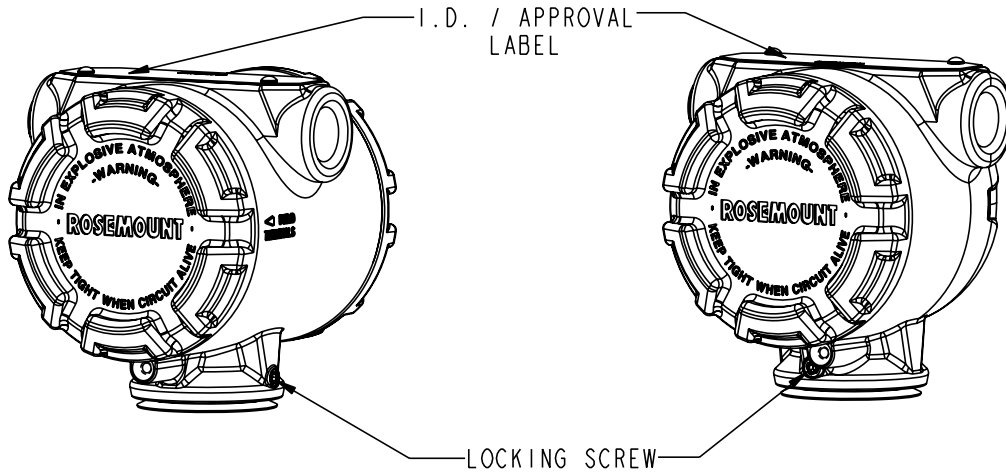

3051S SERIES
 SCALABLE COPLANAR
 PRESSURE TRANSMITTER

3051S SERIES
 SCALABLE IN-LINE
 PRESSURE TRANSMITTER

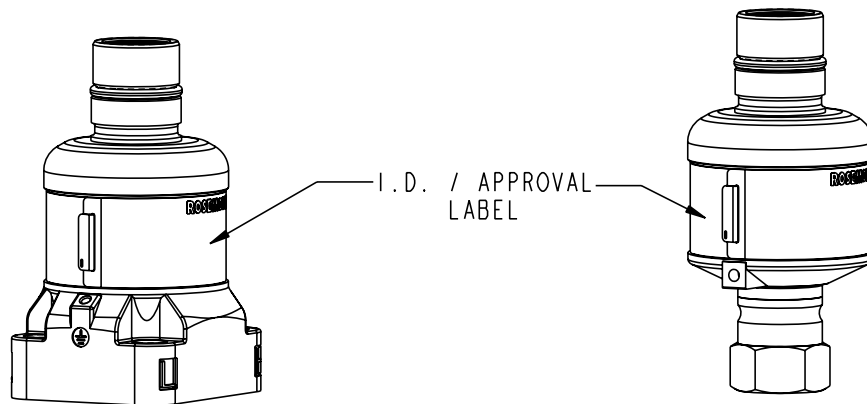

Rosemount Inc.
 8200 Market Boulevard
 Chanhassen, MN 55317 USA

CAD Maintained, (Pro/E)

DR. <i>Myles Lee Miller</i>	8/28/00	SIZE A	FSCM NO	DWG NO.	03151-1003
ISSUED		SCALE	1:2	WT.	SHEET 2 OF 3

Form Rev. AC

Rosemount 3051S Series

REVISIONS					
ZONE	REV	DESCRIPTION	CHG. NO.	APP'D	DATE
	AC				

HOUSING TO MODULE ASSEMBLY

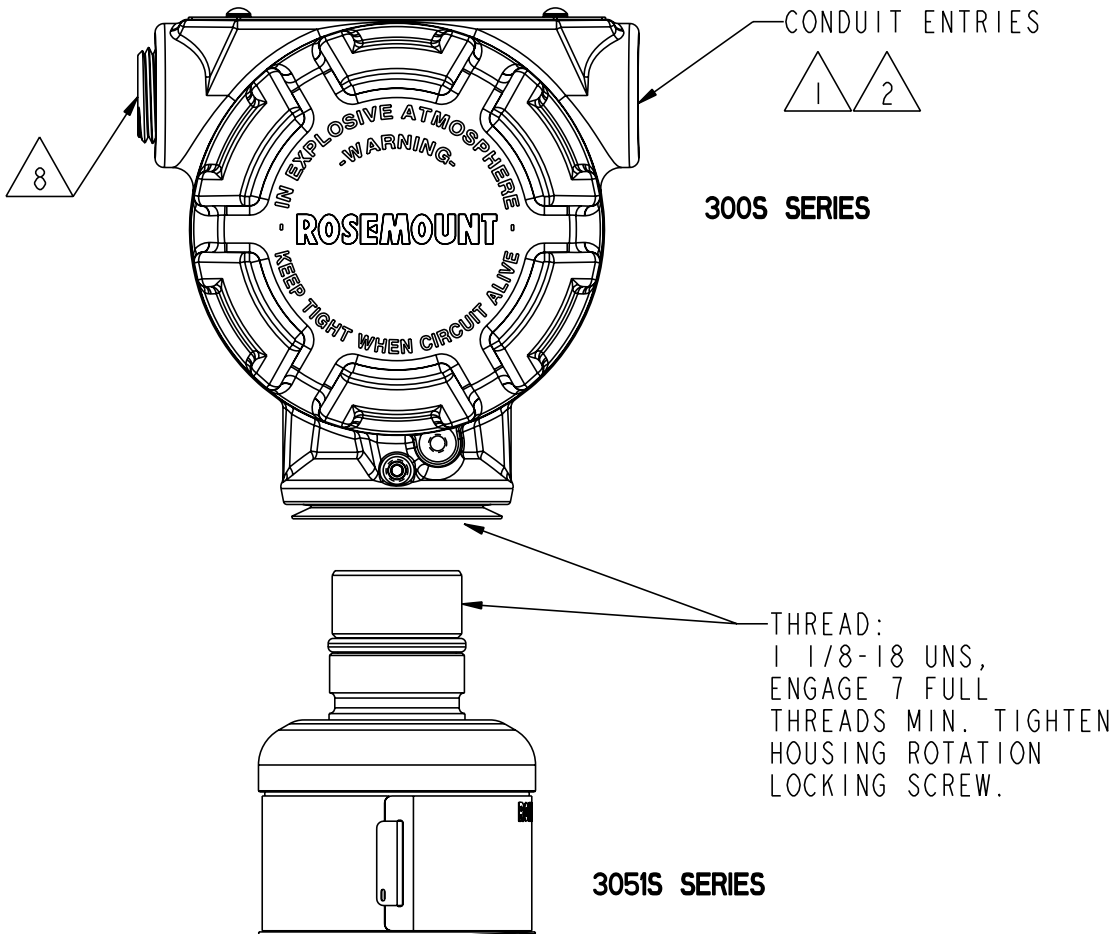

Rosemount Inc.
 8200 Market Boulevard
 Chanhassen, MN 55317 USA

CAD Maintained, (Pro/E)

DR. <i>Myles Lee Miller</i>	8/28/00	SIZE A	FSCM NO.	DWG NO. 03151-1003
ISSUED		SCALE 1 : 4	WT.	SHEET 3 OF 3

Form Rev. AC

CONFIDENTIAL AND PROPRIETARY INFORMATION IS CONTAINED HEREIN AND MUST BE HANDLED ACCORDINGLY	REVISIONS				
	REV	DESCRIPTION	CHG. NO.	APP'D	DATE
	AM	ADD DIAGNOSTICS FEATURE BOARD	RTC1020856	J.D.V.	3/23/06
	AN	REMOVE T5	RTC1024820	H.G.	10/23/07
	AP	UPDATE CURRENT FOR HART DIAGNOSTICS SUITE AND 300S; REMOVE OUTPUT 'B'; UPDATE FISCO CURRENT AND POWER	RTC1027772	T.T.S.	2/6/09

ENTITY APPROVALS FOR MODELS 3051S & 300S

OUTPUT CODE A (4-20 mA HART) I.S. SEE SHEETS 2-4
 REMOTE DISPLAY (4-20 mA HART) I.S. SEE SHEET 5
 OUTPUT CODE F/W (FIELDBUS/PROFIBUS) I.S. SEE SHEET 6
 FISCO SEE SHEETS 7-8
 ALL OUTPUT CODES NONINCENDIVE SEE SHEET 9

THE ROSEMOUNT TRANSMITTERS LISTED ABOVE ARE F.M. APPROVED AS INTRINSICALLY SAFE WHEN USED IN CIRCUIT WITH F.M. APPROVED BARRIERS WHICH MEET THE ENTITY PARAMETERS LISTED IN THE CLASS I, II, AND III, DIVISION 1 GROUPS INDICATED.

TO ASSURE AN INTRINSICALLY SAFE SYSTEM, THE TRANSMITTER AND BARRIER MUST BE WIRED IN ACCORDANCE WITH THE BARRIER MANUFACTURER'S FIELD WIRING INSTRUCTIONS AND THE APPLICABLE CIRCUIT DIAGRAM.

CAD MAINTAINED (MicroStation)

UNLESS OTHERWISE SPECIFIED DIMENSIONS IN INCHES (mm). REMOVE ALL BURRS AND SHARP EDGES. MACHINE SURFACE FINISH 125 -TOLERANCE- .X ± .1 [2,5] .XX ± .02 [0,5] .XXX ± .010 [0,25] FRACTIONS ANGLES ± 1/32 ± 2° DO NOT SCALE PRINT	CONTRACT NO.	 ROSEMOUNT® 8200 Market Boulevard • Chanhassen, MN 55317 USA		
	DR. Myles Lee Miller 2/23/01	TITLE		
	CHK'D	INDEX OF I.S. & NONINCENDIVE F.M. FOR 3051S		
	APP'D. Paul C. Sundet 3/9/01	SIZE	FSCM NO	DWG NO. 03151-1006
	APP'D. GOVT.	A		
	SCALE	N/A	WT. _____ SHEET 1 OF 10	

From Rev. A/C

REVISIONS				
REV	DESCRIPTION	CHG. NO.	APP'D	DATE
AP				

ENTITY CONCEPT APPROVALS

THE ENTITY CONCEPT ALLOWS INTERCONNECTION OF INTRINSICALLY SAFE APPARATUS TO ASSOCIATED APPARATUS NOT SPECIFICALLY EXAMINED IN COMBINATION AS A SYSTEM. THE APPROVED VALUES OF MAX. OPEN CIRCUIT VOLTAGE (V_{oc} , U_o OR V_t) AND MAX. SHORT CIRCUIT CURRENT (I_{sc} , I_o , OR I_t) AND MAX. POWER $P_o(V_{oc} \times I_{sc}/4)$ OR $(V_t \times I_t/4)$, FOR THE ASSOCIATED APPARATUS MUST BE LESS THAN OR EQUAL TO THE MAXIMUM SAFE INPUT VOLTAGE (V_{max} , OR U_i), MAXIMUM SAFE INPUT CURRENT (I_{max} OR I_i), AND MAXIMUM SAFE INPUT POWER (P_{max} OR P_i) OF THE INTRINSICALLY SAFE APPARATUS. IN ADDITION, THE APPROVED MAX. ALLOWABLE CONNECTED CAPACITANCE (C_a) OF THE ASSOCIATED APPARATUS MUST BE GREATER THAN THE SUM OF THE INTERCONNECTING CABLE CAPACITANCE AND THE UNPROTECTED INTERNAL CAPACITANCE (C_i) OF THE INTRINSICALLY SAFE APPARATUS, AND THE APPROVED MAX. ALLOWABLE CONNECTED INDUCTANCE (L_a) OF THE ASSOCIATED APPARATUS MUST BE GREATER THAN THE SUM OF THE INTERCONNECTING CABLE INDUCTANCE AND THE UNPROTECTED INTERNAL INDUCTANCE (L_i) OF THE INTRINSICALLY SAFE APPARATUS.

NOTE: ENTITY PARAMETERS LISTED APPLY ONLY TO ASSOCIATED APPARATUS WITH LINEAR OUTPUT.

FOR OUTPUT CODE 'A' MODEL 3051S SUPERMODULE CLASS I, DIV. 1, GROUPS A, B, C AND D

U_i or $V_{MAX} = 30V$	U_o , V_T or V_{OC} IS LESS THAN OR EQUAL TO 30V
I_i or $I_{MAX} = 300mA$	I_o , I_T or I_{SC} IS LESS THAN OR EQUAL TO 300mA
P_i or $P_{MAX} = 1.0$ WATT	$(\frac{V_T \times I_T}{4})$ or $(\frac{V_{oc} \times I_{sc}}{4})$ IS LESS THAN OR EQUAL TO 1.0 WATT
$C_i = 38nF$	C_A IS GREATER THAN 38nF
$L_i = 0$	L_A IS GREATER THAN 0 H
T4 ($T_a = -50^\circ C$ to $+70^\circ C$)	

FOR OUTPUT CODE 'A' MODEL 300S JUNCTION BOX, 300S PLANTWEB HOUSING, OR 3051S QUICK CONNECT CLASS I, DIV. 1, GROUPS A, B, C AND D

U_i or $V_{MAX} = 30V$	U_o , V_T or V_{OC} IS LESS THAN OR EQUAL TO 30V
I_i or $I_{MAX} = 300mA$	I_o , I_T or I_{SC} IS LESS THAN OR EQUAL TO 300mA
P_i or $P_{MAX} = 1.0$ WATT	$(\frac{V_T \times I_T}{4})$ or $(\frac{V_{oc} \times I_{sc}}{4})$ IS LESS THAN OR EQUAL TO 1.0 WATT
$C_i = 11.4nF$	C_A IS GREATER THAN 11.4nF
$L_i = 2.4\mu H$	L_A IS GREATER THAN 2.4 μH
T4 ($T_a = -50^\circ C$ to $+70^\circ C$)	

FOR OUTPUT CODE 'A' WITH HART DIAGNOSTICS SUITE AND MODEL 300S PLANTWEB HOUSING CLASS I, DIV. 1, GROUPS A, B, C AND D

U_i or $V_{MAX} = 30V$	U_o , V_T or V_{OC} IS LESS THAN OR EQUAL TO 30V
I_i or $I_{MAX} = 300mA$	I_o , I_T or I_{SC} IS LESS THAN OR EQUAL TO 300mA
P_i or $P_{MAX} = 1.0$ WATT	$(\frac{V_T \times I_T}{4})$ or $(\frac{V_{oc} \times I_{sc}}{4})$ IS LESS THAN OR EQUAL TO 1.0 WATT
$C_i = 11.4nF$	C_A IS GREATER THAN 11.4nF
$L_i = 0$	L_A IS GREATER THAN 0
T4 ($T_a = -50^\circ C$ to $+70^\circ C$)	

Rosemount Inc. 8200 Market Boulevard Chanhassen, MN 55317 USA	CAD MAINTAINED (MicroStation)		
DR. Myles Lee Miller	SIZE A	FSCM NO	DWG NO. 03151-1006
ISSUED	SCALE N/A	WT. _____	SHEET 2 OF 10

Form Rev. AC

REVISIONS				
REV	DESCRIPTION	CHG. NO.	APP'D	DATE
AP				

CIRCUIT DIAGRAM 1
 ONE BARRIER OR CONVERTER:
 SINGLE OR DUAL CHANNEL

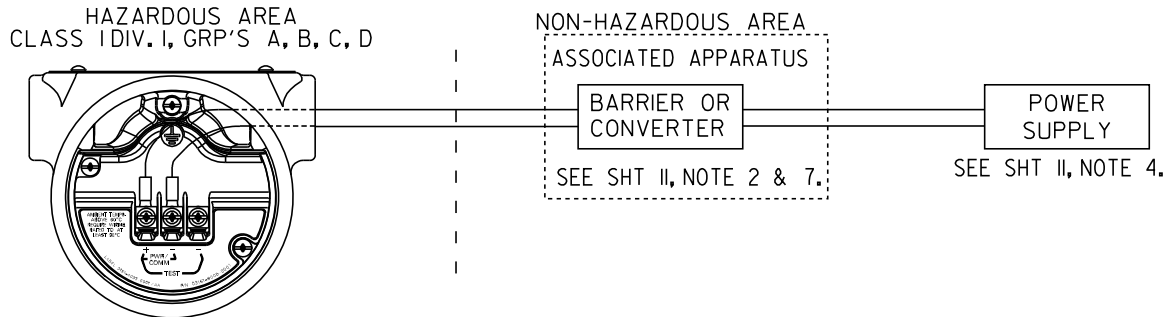

OUTPUT CODE A & B
 MODELS INCLUDED
 3051S WITH 300S
 JUNCTION BOX or
 PLANTWEB HOUSING

CIRCUIT DIAGRAM 2
 SUPPLY AND RETURN BARRIERS
 (ONLY FOR USE WITH BARRIERS APPROVED IN THIS CONFIGURATION)

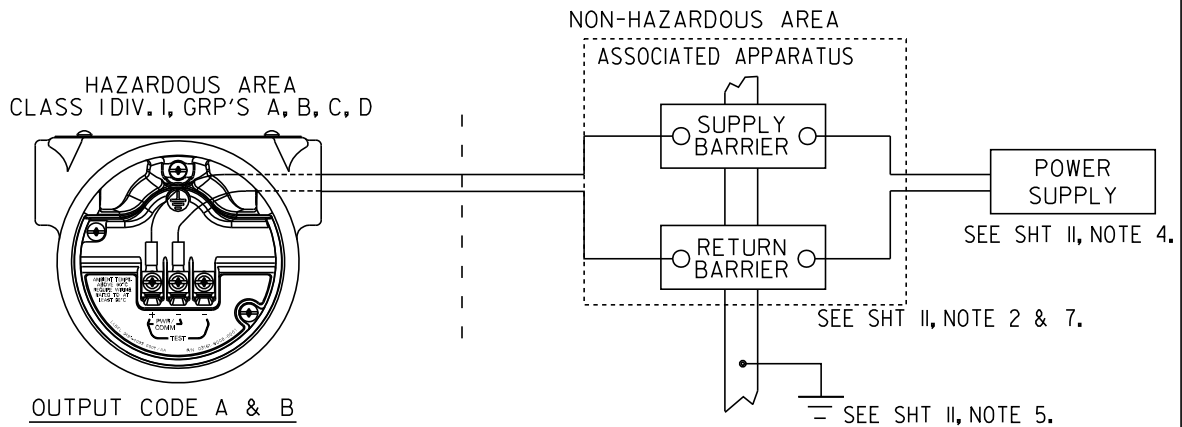

OUTPUT CODE A & B
 MODELS INCLUDED
 3051S WITH 300S
 JUNCTION BOX or
 PLANTWEB HOUSING

Rosemount Inc.
 8200 Market Boulevard
 Chanhassen, MN 55317 USA

CAD MAINTAINED (MicroStation)

DR.	Mylee Lee Miller	SIZE	A	FSCM NO.		DWG NO.	03151-1006
ISSUED		SCALE	N/A	WT.		SHEET	3 OF 10

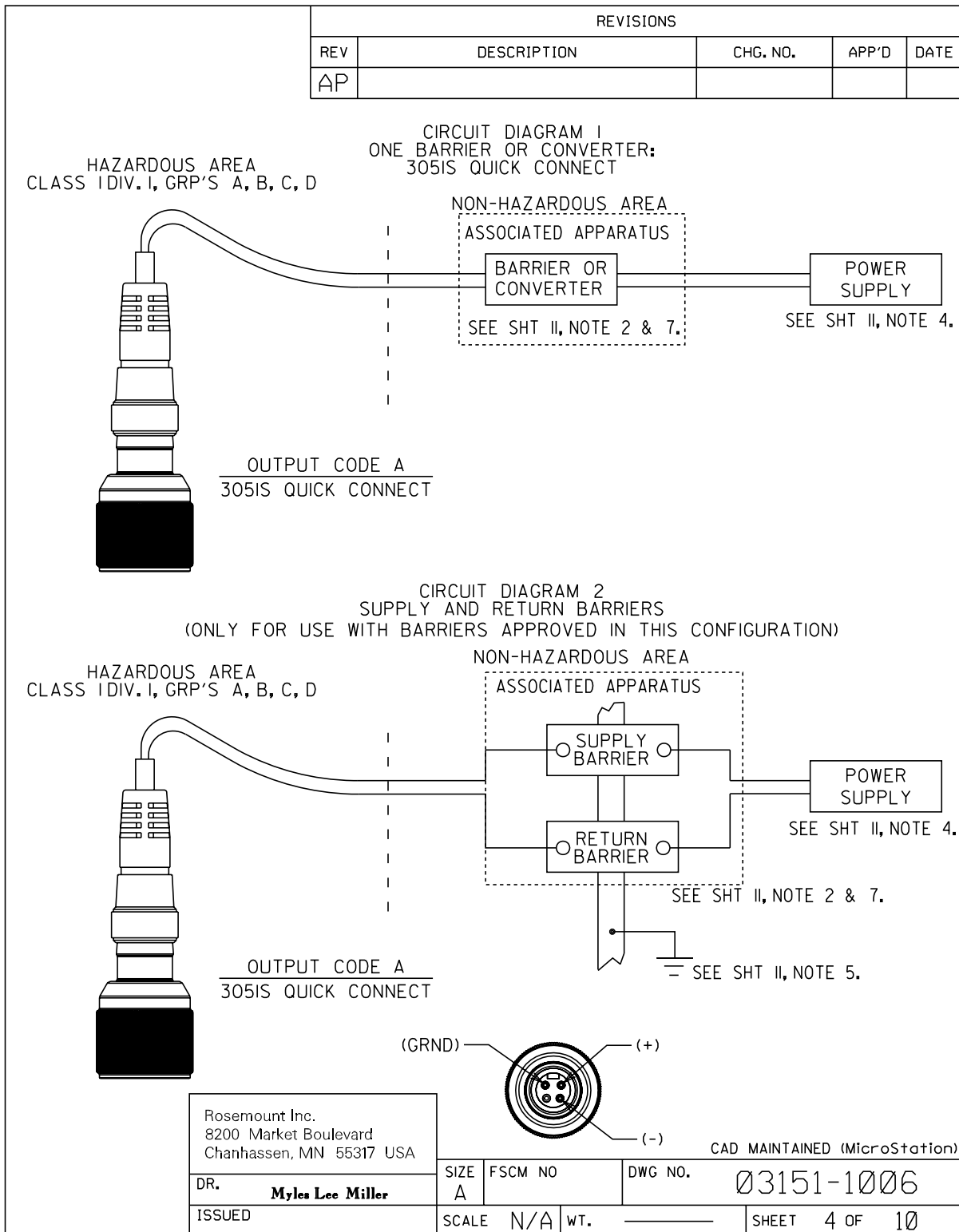

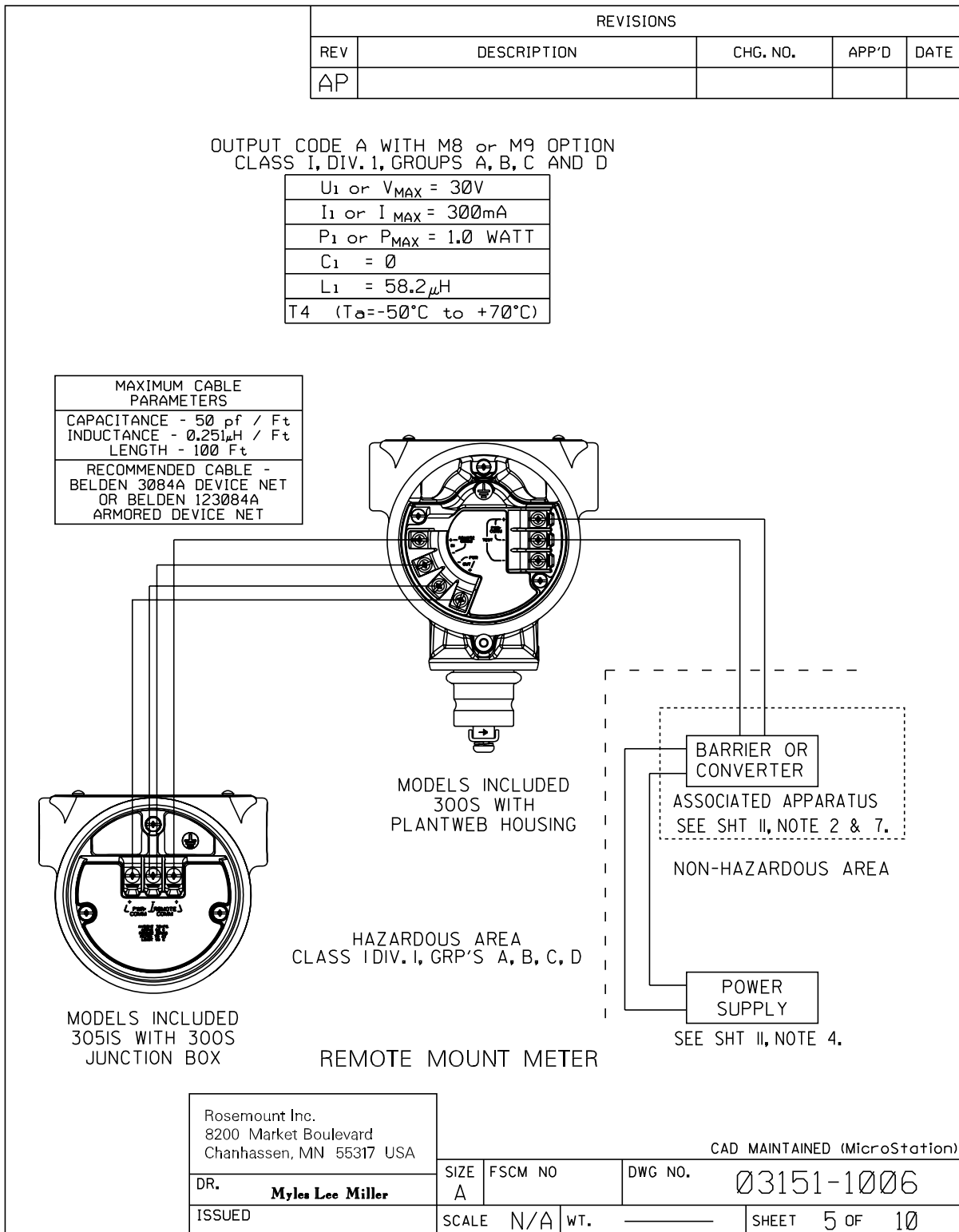

Eaton, Rev. AC

REVISIONS				
REV	DESCRIPTION	CHG. NO.	APP'D	DATE
AP				

FOR OUTPUT CODE F or W (MODEL 300S)
CLASS I, DIV. 1, GROUPS A, B, C AND D

U_I OR $V_{MAX} = 30V$	$U_O, V_T, OR V_{OC}$ IS LESS THAN OR EQUAL TO 30V
I_I OR $I_{MAX} = 300mA$	$I_O, I_T, OR I_{SC}$ IS LESS THAN OR EQUAL TO 300mA
P_I OR $P_{MAX} = 1.3$ WATT	$P_I (\frac{V_{IX} \times I_I}{4})$ OR $(\frac{V_{OC} \times I_{SC}}{4})$ IS LESS THAN OR EQUAL TO 1.3 WATT
$C_T = 0 \mu f$	C_A IS GREATER THAN $0 \mu f$
$L_T = 0 \mu H$	L_A IS GREATER THAN $0 \mu H$
$T_4 (T_a = -50^\circ C TO +60^\circ C)$	

CIRCUIT DIAGRAM I
ONE BARRIER OR CONVERTER;
SINGLE OR DUAL CHANNEL

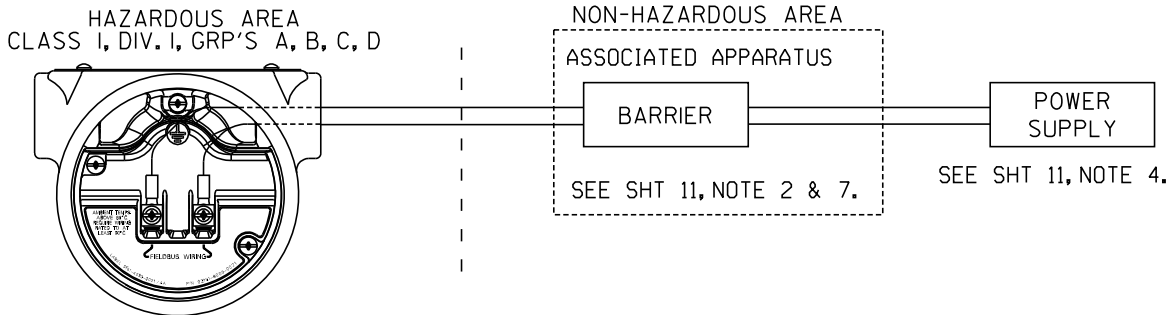

OUTPUT CODE F or W
MODELS INCLUDED
3051S WITH 300S
PLANTWEB HOUSING

Rosemount Inc. 8200 Market Boulevard Chanhassen, MN 55317 USA		CAD MAINTAINED (MicroStation)	
DR.	Myles Lee Miller	SIZE	A
ISSUED		FSCM NO.	DWG NO. 03151-1006
		SCALE	N/A WT. _____ SHEET 6 OF 10

From Rev AC

REVISIONS				
REV	DESCRIPTION	CHG. NO.	APP'D	DATE
AP				

FISCO CONCEPT

THE FISCO CONCEPT ALLOWS INTERCONNECTION OF INTRINSICALLY SAFE APPARATUS TO ASSOCIATED APPARATUS NOT SPECIALLY EXAMINED IN SUCH COMBINATION. THE CRITERIA FOR INTERCONNECTION IS THAT THE VOLTAGE (U_i OR V_{max}), THE CURRENT (I_i OR I_{max}), AND THE POWER (P_i OR P_{max}) WHICH AN INTRINSICALLY SAFE APPARATUS CAN RECEIVE AND REMAIN INTRINSICALLY SAFE CONSIDERING FAULTS, MUST BE EQUAL OR GREATER THAN VOLTAGE (U_o , V_{oc} , OR V_t), THE CURRENT (I_o , I_{sc} , OR I_t) AND THE POWER (P_o OR P_{max}) LEVELS WHICH CAN BE DELIVERED BY THE ASSOCIATED APPARATUS, CONSIDERING FAULTS AND APPLICABLE FACTORS. IN ADDITION, THE MAXIMUM UNPROTECTED CAPACITANCE (C_i) AND THE INDUCTANCE (L_i) OF EACH APPARATUS (OTHER THAN THE TERMINATION) CONNECTED TO THE FIELDBUS MUST BE LESS THAN OR EQUAL TO 5 nF AND 10 μ H RESPECTIVELY.

IN EACH SEGMENT ONLY ONE ACTIVE DEVICE, NORMALLY THE ASSOCIATED APPARATUS, IS ALLOWED TO PROVIDE THE NECESSARY ENERGY FOR THE FIELDBUS SYSTEM. THE VOLTAGE U_o (OR V_{oc} OR V_t) OF THE ASSOCIATED APPARATUS IS LIMITED TO A RANGE OF 14V TO 24Vd.c. ALL OTHER EQUIPMENT CONNECTED TO THE BUS CABLE HAS TO BE PASSIVE, MEANING THAT THEY ARE NOT ALLOWED TO PROVIDE ENERGY TO THE SYSTEM, EXCEPT A LEAKAGE CURRENT OF 50 μ A FOR EACH CONNECTED DEVICE. SEPARATELY POWERED EQUIPMENT NEEDS GALVANIC ISOLATION TO ASSURE THAT THE INTRINSICALLY SAFE FIELDBUS CIRCUIT REMAINS PASSIVE.

THE CABLE USED TO INTERCONNECT DEVICES NEEDS TO HAVE THE PARAMETERS IN THE FOLLOWING RANGE:

- Loop Resistance R': 15.....150 Ohm/km
- Inductance per unit length L': 0.4.....1 mH/km
- Capacitance per unit length C': 80.....200 nF
- C' = C' line/line + 0.5C' line/screen, if both lines are floating, or
- C' = C' line/line + C' line/screen, if the screen is connected to one line
- Length of trunk cable: less than or equal to 1000m
- Length of spur cable: less than or equal to 30m
- Length of spur splice: less than or equal to 1m

AT EACH END OF THE TRUNK CABLE AN APPROVED INFALLIBLE LINE TERMINATION WITH THE FOLLOWING PARAMETERS IS SUITABLE:

R = 90.....1000hm C = 0.....2.2uF

ONE OF THE ALLOWED TERMINATIONS MIGHT ALREADY BE INTEGRATED IN THE ASSOCIATED APPARATUS. THE NUMBER OF PASSIVE APPARATUS CONNECTED TO THE BUS SEGMENT IS NOT LIMITED DUE TO I. S. REASONS. IF THE ABOVE RULES ARE RESPECTED, UP TO A TOTAL LENGTH OF 1000 m (SUM OF TRUNK AND ALL SPUR CABLES) OF CABLE IS PERMITTED. THE INDUCTANCE AND THE CAPACITANCE OF THE CABLE WILL NOT IMPAIR THE INTRINSIC SAFETY OF THE INSTALLATION.

Rosemount Inc. 8200 Market Boulevard Chanhassen, MN 55317 USA		CAD MAINTAINED (MicroStation)		
DR. Myles Lee Miller	SIZE A	FSCM NO.	DWG NO. 03151-1006	
ISSUED	SCALE N/A	WT.	SHEET 7 OF 10	

Form Rev. AC

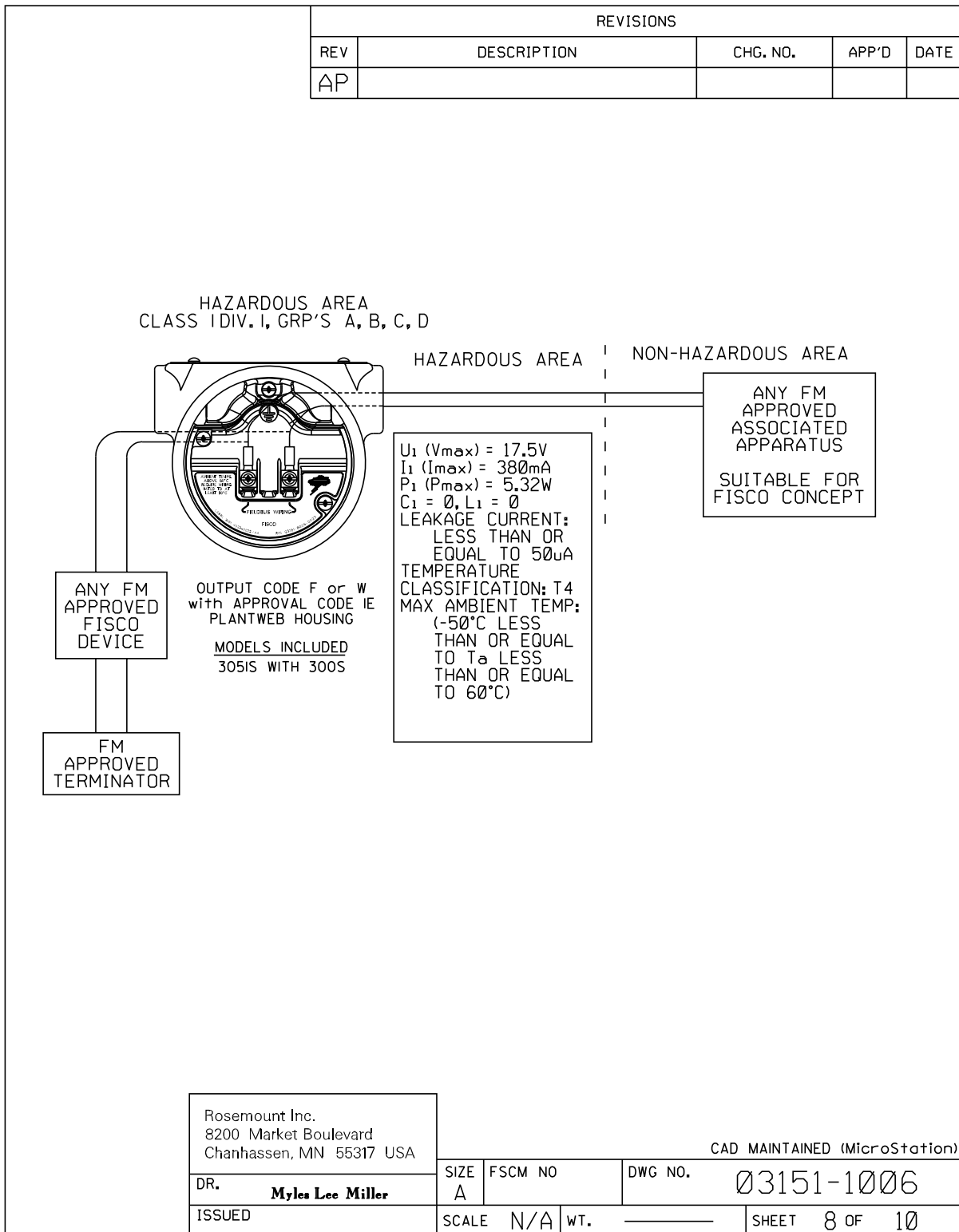

Elev. Rev. AC

REVISIONS				
REV	DESCRIPTION	CHG. NO.	APP'D	DATE
AP				

NON-CLASSIFIED LOCATION

APPROVED
NONINCENDIVE
SUPPLY

Voc
Ca
La

SEE SHT 11,
NOTES 2, 4, & 11

NONINCENDIVE FIELD CIRCUIT
CLASS 1, DIV. 2 LOCATIONS

HAZARDOUS (CLASSIFIED) LOCATION
CLASS 1, DIV. 2, GRP'S A, B, C, D

V_{max1}	V_{max2}	V_{max3}	V_{maxN}
CI_1	CI_2	CI_3	CI_N
LI_1	LI_2	LI_3	LI_N
I_{max1}	I_{max2}	I_{max3}	I_{maxN}

WIRING PER NEC (NFPA 70) ARTICLE 501-4 (b) EXCEPTION (NONINCENDIVE FIELD CIRCUIT) NFPA 70 National Electrical Code ARTICLE 501-4(b) EXCEPTION; "WIRING IN NONINCENDIVE CIRCUITS SHALL BE PERMITTED USING ANY OF THE METHODS SUITABLE FOR WIRING IN ORDINARY LOCATIONS."

IN NORMAL OPERATION
DEVICES CONTROL THROUGH-CURRENT

PARAMETERS (NON-INCENDIVE FIELD WIRING)	DEVICE	ROSEMOUNT 3051S/300S					
		3051S 4-20mA / HART	MODEL 300S REMOTE METER	3051S QUICK CONNECT OR 300S OUTPUT CODE 'A'	MODEL 300S HART DIAGNOSTICS OUTPUT CODE 'A'	300S OUTPUT CODE 'B' (SAFETY CERTIFIED)	FIELDBUS (F or W)
Vmax		42.4v	42.4v	42.4v	42.4v	42.4v	35v
Maximum normal operating current		22mA	22mA	22mA	22mA	22mA	27mA
C1		38nF	0nF	11.4nF	11.4nF	11.4nF	0uF
L1		0uH	58.2uH	2.4uH	0uH	570uH	0uH

$I_{maxN} \geq I_{qN} + I_{signalN}$

I_{max} for an individual device = $I_q + I_{signal}$

I_q = Quiescent current through device
(Maximum quiescent current for the device)

I_{signal} = Signaling current through device
(Protocol may limit signaling to one device at a time)

Operating $I_{max} = I_{q1} + I_{q2} + \dots + I_{qN} + I_{signal\ max}$
 $I_{signal\ max} = \text{Max. of } (I_{signal1}, I_{signal2}, \dots, I_{signalN})$

TEMP CODE: T4 (Ta = -50°C TO +70°C)

Rosemount Inc.
8200 Market Boulevard
Chanhassen, MN 55317 USA

CAD MAINTAINED (MicroStation)

DR.	Myles Lee Miller	SIZE	FSCM NO	DWG NO.	03151-1006
ISSUED		SCALE	N/A	WT.	
				SHEET	9 OF 10

Form Rev. AC

REVISIONS				
REV	DESCRIPTION	CHG. NO.	APP'D	DATE
AP				

NOTES:

1. NO REVISION TO THIS DRAWING WITHOUT PRIOR FACTORY MUTUAL APPROVAL.
2. ASSOCIATED APPARATUS MANUFACTURER'S INSTALLATION DRAWING MUST BE FOLLOWED WHEN INSTALLING THIS EQUIPMENT.
3. DUST-TIGHT CONDUIT SEAL MUST BE USED WHEN INSTALLED IN CLASS II AND CLASS III ENVIRONMENTS.
4. CONTROL EQUIPMENT CONNECTED TO BARRIER MUST NOT USE OR GENERATE MORE THAN 250 Vrms or Vdc.
5. RESISTANCE BETWEEN INTRINSICALLY SAFE GROUND AND EARTH GROUND MUST BE LESS THAN 1 OHM.
6. INSTALLATION SHOULD BE IN ACCORDANCE WITH ANSI/ISA-RP12.6 "INSTALLATION OF INTRINSICALLY SAFE SYSTEMS FOR HAZARDOUS (CLASSIFIED) LOCATIONS" AND THE NATIONAL ELECTRICAL CODE (ANSI/NFPA 70).
7. THE ASSOCIATED APPARATUS MUST BE FACTORY MUTUAL APPROVED.
8. WARNING - SUBSTITUTION OF COMPONENTS MAY IMPAIR INTRINSIC AND NON-INCENDIVE SAFETY.
9. ASSOCIATED APPARATUS MUST MEET THE FOLLOWING PARAMETERS:
 U_o or V_{oc} or V_t LESS THAN or EQUAL TO U_1 (V_{max})
 I_o or I_{sc} or I_t LESS THAN or EQUAL TO I_1 (I_{max})
 P_o or P_{max} LESS THAN or EQUAL TO P_1 (P_{max})
 C_a IS GREATER THAN or EQUAL THE SUM OF ALL C_i 's PLUS C_{cable}
 L_a IS GREATER THAN or EQUAL THE SUM OF ALL L_i 's PLUS L_{cable}
10. WARNING - TO PREVENT IGNITION OF FLAMMABLE OR COMBUSTIBLE ATMOSPHERES, DISCONNECT POWER BEFORE SERVICING.
11. THE ASSOCIATED APPARATUS MUST BE A RESISTIVELY LIMITED SINGLE OR MULTIPLE CHANNEL FM APPROVED BARRIER HAVING PARAMETERS LESS THAN THOSE QUOTED, AND FOR WHICH THE OUTPUT AND THE COMBINATIONS OF OUTPUTS IS NON-IGNITION CAPABLE FOR THE CLASS, DIVISION AND GROUP OF USE.
12. FIELD WIRING SHOULD BE RATED TO 70°C.

Rosemount Inc. 8200 Market Boulevard Chanhassen, MN 55317 USA	CAD MAINTAINED (MicroStation)			
DR. Myles Lee Miller	<table border="1" style="width: 100%; border-collapse: collapse;"> <tr> <td style="width: 15%;">SIZE A</td> <td style="width: 25%;">FSCM NO</td> <td style="width: 60%;">DWG NO. 03151-1006</td> </tr> </table>	SIZE A	FSCM NO	DWG NO. 03151-1006
SIZE A	FSCM NO	DWG NO. 03151-1006		
ISSUED	<table border="1" style="width: 100%; border-collapse: collapse;"> <tr> <td style="width: 30%;">SCALE N/A</td> <td style="width: 30%;">WT. _____</td> <td style="width: 40%;">SHEET 10 OF 10</td> </tr> </table>	SCALE N/A	WT. _____	SHEET 10 OF 10
SCALE N/A	WT. _____	SHEET 10 OF 10		

Form Rev. AC

CONFIDENTIAL AND PROPRIETARY INFORMATION IS CONTAINED HEREIN AND MUST BE HANDLED ACCORDINGLY.	REVISIONS				
	REV	DESCRIPTION	ECO NO.	APP'D	DATE
	AB	ADD NOTES 5 & 6	RTC1027013	T.T.S.	10/15/08

NOTES:

1. USE TURCK CORDSETS AS SPECIFIED IN THIS DRAWING WITH GE / GM OPTION TO ENSURE OUTDOOR RATING (NEMA 4X or IP66).



2. LOK-FAST GUARD IS REQUIRED FOR CLASS 1 DIVISION 2 INSTALLATIONS.





3. (X)XXV 49-.114M/14.5 IS INSTALLED INTO 1/2-14 NPT CONDUIT ENTRY THREADS. (X)XXV 49-.114M/M20 IS INSTALLED INTO CM20 CONDUIT ENTRY THREADS.

4. eurofast[®] AND minifast[®] ARE REGISTERED TRADEMARKS OF TURCK INC.

5. SEE TURCK CONTROL DRAWING QCF-00147 (FM) OR NI-2.404 (CSA) FOR GUIDANCE ON INSTALLATION OF CORDSETS IN HAZARDOUS LOCATIONS.



6. RECEPTACLE REQUIRED FOR USE WITH EQUIPMENT APPROVED AS EXPLOSION-PROOF FOR CLASS 1, DIV 1 LOCATIONS.

UNLESS OTHERWISE SPECIFIED DIMENSIONS IN INCHES [mm]. REMOVE ALL BURRS AND SHARP EDGES. MACHINE SURFACE FINISH 125	  8200 Market Boulevard Chanhassen, MN 55317 USA							
	TITLE GE / GM OPTION NEMA 4X INSTALLATION, FM							
-TOLERANCES-	DR.	Myles Lee Miller	8/29/06	SIZE	DRAWING NO.	03151-1009	REV	AB
.X ± .1 [2,5] .XX ± .02 [0,5] .XXX ± .010 [0,25]	APP'D	Bryce Hagbom	8/30/06	A				
FRACTIONS ± 1/32 ANGLES ± 2°	CAD MAINTAINED, (PRO/E)				SHEET 1 OF 3			
DO NOT SCALE PRINT								

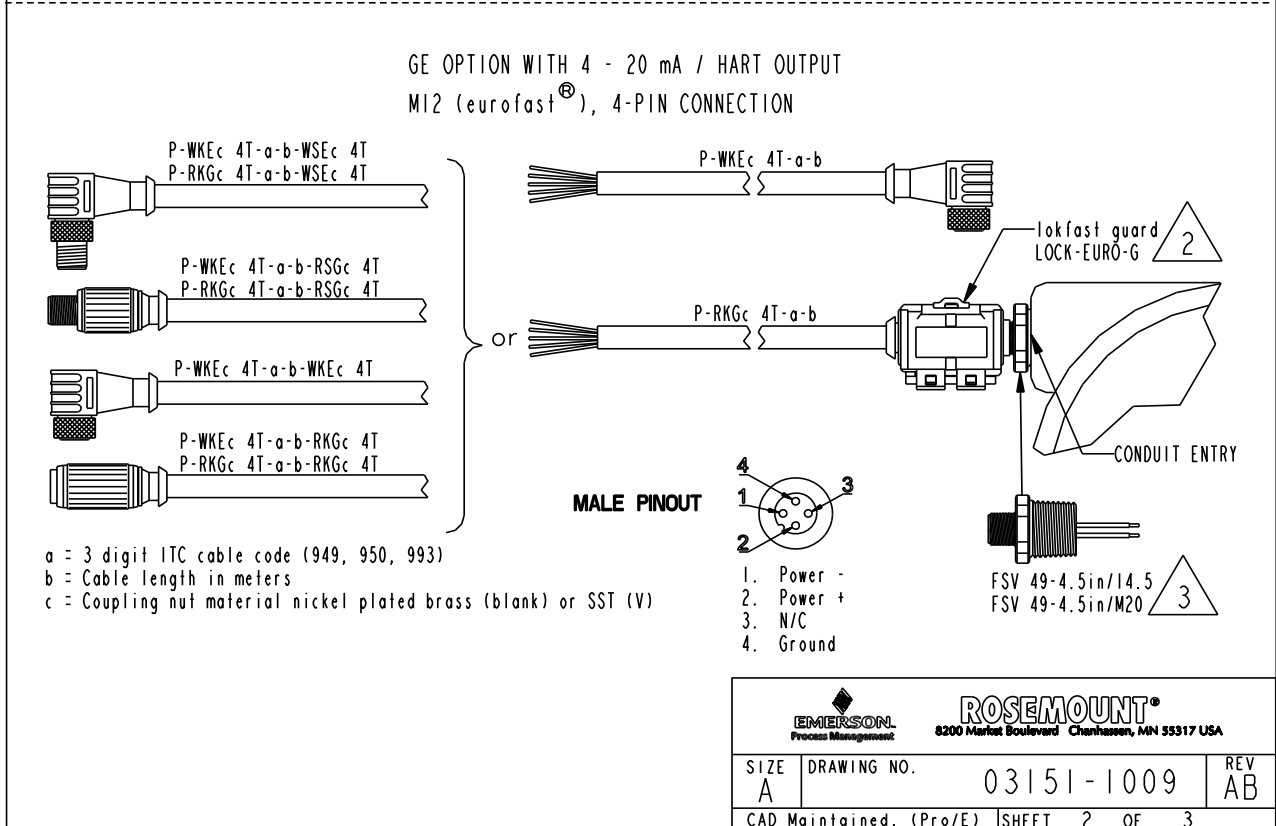
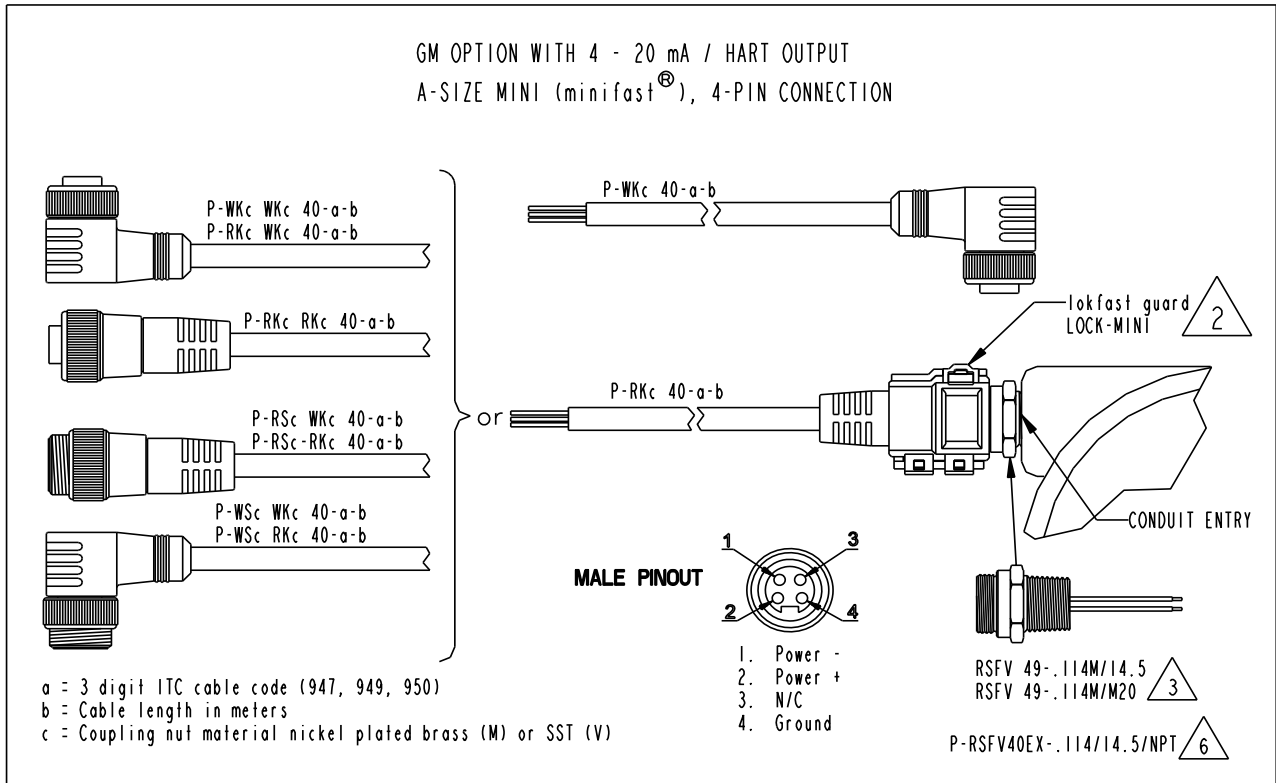

EMERSON Process Management		ROSEMOUNT® 8200 Market Boulevard Chanhassen, MN 55317 USA	
SIZE A	DRAWING NO. 03151-1009	REV AB	
CAD Maintained, (Pro/E)		SHEET 2 OF 3	

GM OPTION WITH FOUNDATION FIELDBUS
 A-SIZE MINI (minifast®), 4-PIN CONNECTION

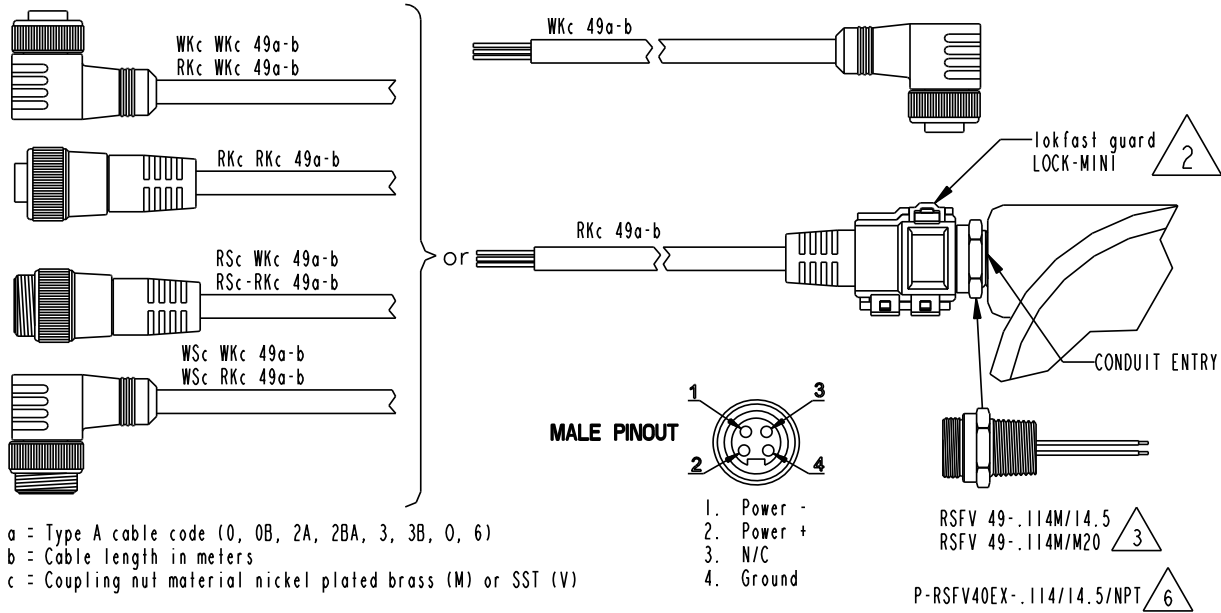

GE OPTION WITH FOUNDATION FIELDBUS
 M12 (eurofast®), 4-PIN CONNECTION

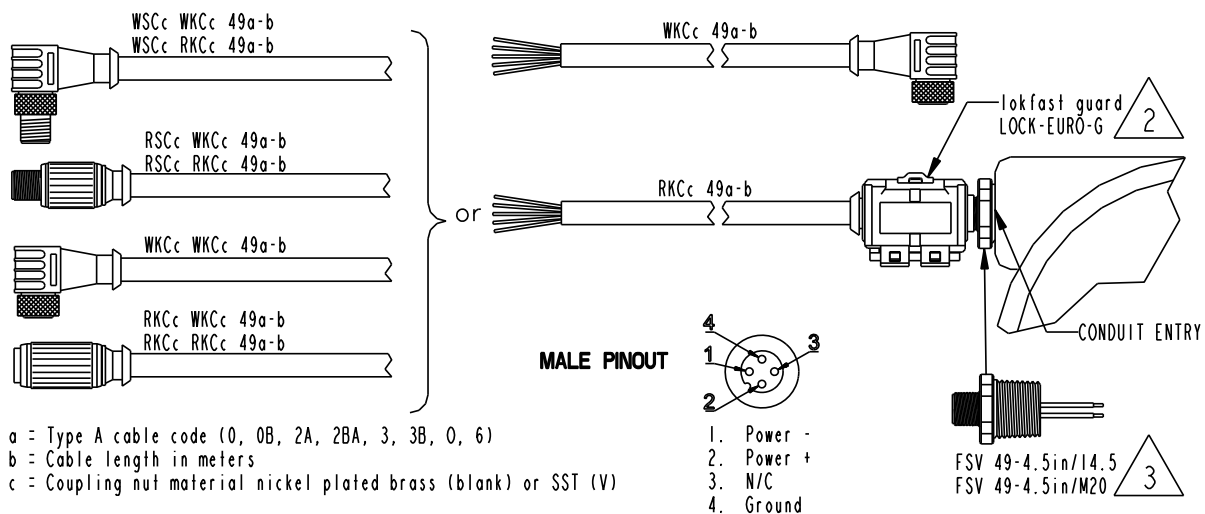

		ROSEMOUNT® 8200 Market Boulevard Chanhassen, MN 55317 USA	
SIZE A	DRAWING NO. 03151-1009	REV AB	
CAD Maintained, (Pro/E)		SHEET 3 OF 3	

Rosemount 3051S Series

Canadian Standards Association (CSA)

CONFIDENTIAL AND PROPRIETARY INFORMATION IS CONTAINED HEREIN AND MUST BE HANDLED ACCORDINGLY.	REVISIONS					
	ZONE	REV	DESCRIPTION	CHG. NO.	APP'D	DATE
		AF	CORRECT TYPO IN NOTE 10	RTC1026088	T.T.S.	4/30/08
		AG	UPDATE DRAWING	RTC1030895	A.J.W.	5/12/10

NOTES:

1. WIRING METHOD SUITABLE FOR CLASS I, DIV I WITH ANY LENGTH.
2. TRANSMITTER MUST NOT BE CONNECTED TO EQUIPMENT GENERATING MORE THAN 250 VAC.
3. ALL CONDUIT THREADS TO BE ASSEMBLED WITH FIVE FULL TAPERED THREADS MINIMUM.
4. COMPONENTS REQUIRED TO BE APPROVED MUST BE APPROVED FOR GAS GROUP APPROPRIATE TO AREA CLASSIFICATION.
5. 3051S SERIES SENSOR MODULE MUST BE INSTALLED WITH CSA FLAMEPROOF / EXPLOSIONPROOF APPROVED 300S SERIES HOUSING ATTACHED TO MEET FLAMEPROOF / EXPLOSIONPROOF INSTALLATION REQUIREMENTS. MINIMUM OF 7 FULL THREADS ENGAGED AND LOCKED IN PLACE. SEE PAGE 3.
6. INSTALLATION TO BE IN ACCORDANCE WITH THE LATEST EDITION OF CANADIAN ELECTRICAL CODE.
7. 300S SERIES HOUSING MUST BE INSTALLED WITH CSA FLAMEPROOF / EXPLOSIONPROOF APPROVED 3051S SERIES SENSOR MODULE ATTACHED TO MEET FLAMEPROOF / EXPLOSIONPROOF INSTALLATION REQUIREMENTS. MINIMUM OF 7 FULL THREADS ENGAGED AND LOCKED IN PLACE. SEE PAGE 3.
8. UNUSED CONDUIT ENTRY MUST BE CLOSED WITH SUITABLE BLANKING ELEMENT.
9. TEMPERATURE CODE T5, T_{ambient} = -50°C to 85°C.
10. THIS PRODUCT MEETS THE DUAL SEAL REQUIREMENTS OF ANSI/ISA 12.27.01. NO ADDITIONAL PROCESS SEALING IS REQUIRED. THE DUAL SEAL PROCESS TEMPERATURE RANGE IS -50°C TO 315°C. FOR THE IN-SERVICE LIMITS APPLICABLE TO A SPECIFIC MODEL, SEE "PROCESS TEMPERATURE LIMITS" IN APPENDIX "A" OF THE PRODUCT MANUAL.

CAD Maintained, (Pro/E)

UNLESS OTHERWISE SPECIFIED DIMENSIONS IN INCHES [mm]. REMOVE ALL BURRS AND SHARP EDGES. MACHINE SURFACE FINISH 125 -TOLERANCES- .X ± .1 [2.5] .XX ± .02 [0.5] .XXX ± .010 [0.25] FRACTIONS ANGLES ± 1/32 ± 2° DO NOT SCALE PRINT	CONTRACT NO.		 ROSEMOUNT® 8200 Market Boulevard • Chanhassen, MN 55317 USA			
	DR. <i>Myles Lee Miller</i>	8/28/00	TITLE MODEL 3051 / 300 EXPLOSIONPROOF / FLAMEPROOF INSTALLATION DRAWING, CSA			
	CHK'D		SIZE A			
	APP'D Paul C. Sundet	10/19/00	FSCM NO.	DRAWING NO. 03151-1013		
	APP'D GOVT.		SCALE 1:4	WT.	SHEET 1 OF 3	

REVISIONS					
ZONE	REV	DESCRIPTION	CHG. NO.	APP'D	DATE
	AG				

COMPONENT IDENTIFICATION

300S SERIES PLANTWEB
 (DUAL COMPARTMENT HOUSING)

300S SERIES JUNCTION BOX
 (SINGLE COMPARTMENT)

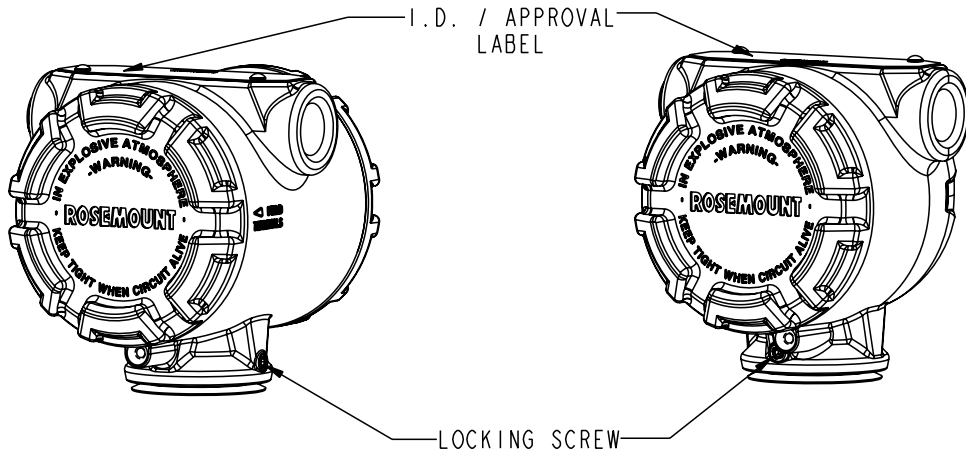

3051S SERIES
 SCALABLE COPLANAR
 PRESSURE TRANSMITTER

3051S SERIES
 SCALABLE IN-LINE
 PRESSURE TRANSMITTER

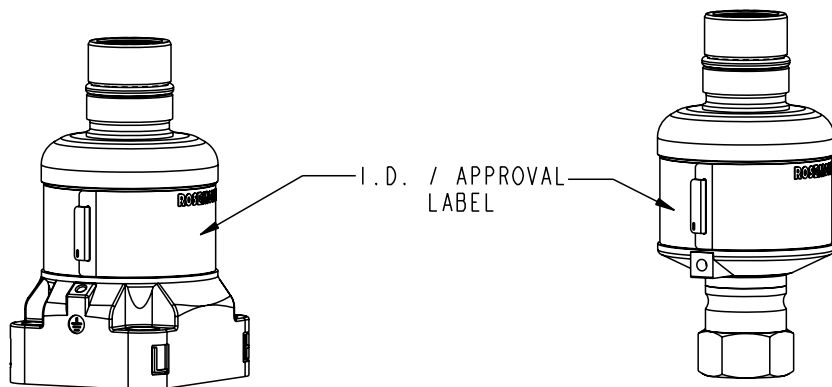

Rosemount Inc. 8200 Market Boulevard Chanasssen, MN 55317 USA			CAD Maintained, (Pro/E)		
DR.	Myles Lee Miller	8/28/00	SIZE A	FSCM NO.	DWG NO. 03151-1013
ISSUED			SCALE 1:2	WT.	SHEET 2 OF 3

FORM REV AC

Rosemount 3051S Series

REVISIONS					
ZONE	REV	DESCRIPTION	CHG. NO.	APP'D	DATE
	AG				

HOUSING TO MODULE ASSEMBLY

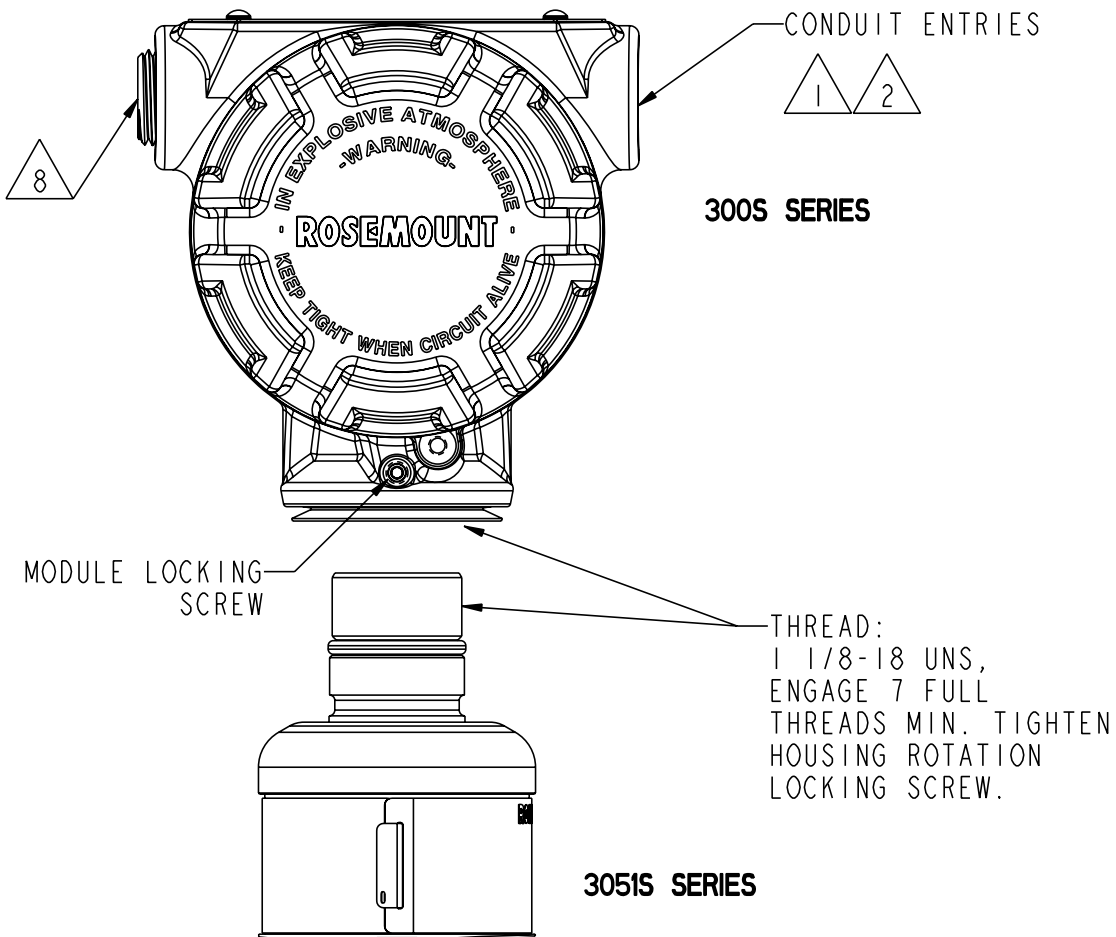

Rosemount Inc.
 8200 Market Boulevard
 Chanhassen, MN 55317 USA

CAD Maintained, (Pro/E)

DR. <i>Myles Lee Miller</i>	8/28/00	SIZE A	FSCM NO	DWG NO.	03151-1013
ISSUED		SCALE	1 : 4	WT.	SHEET 3 OF 3

Form Rev AC

CONFIDENTIAL AND PROPRIETARY INFORMATION IS CONTAINED HEREIN AND MUST BE HANDLED ACCORDINGLY	REVISIONS				
	REV	DESCRIPTION	CHG. NO.	APP'D	DATE
	AJ	ADD QUICK CONNECT	RTC1020189	T.S.	8/31/05
	AK	ADD DIAGNOSTICS FEATURE BOARD	RTC1020856	J.D.V.	3/23/06
	AL	ADD NOTE 7 FOR DUAL SEAL	RTC1025955	T.T.S.	4/23/08
	AM	CORRECT TYPE IN NOTE 7	RTC1026088	T.T.S.	4/30/08

APPROVALS FOR

OUTPUT CODES A,B,F,W I.S. ENTITY PARAMETERS SHEETS 2-3
 OUTPUT CODES A,B (4-20 mA HART) I.S. SEE SHEETS 4-7
 REMOTE METER (4-20 mA HART) I.S. SEE SHEET 6
 OUTPUT CODE F/W (FIELDBUS) I.S. SEE SHEET 8
 FISCO SEE SHEETS 9-10

TO ASSURE AN INTRINSICALLY SAFE SYSTEM, THE TRANSMITTER AND BARRIER MUST BE WIRED IN ACCORDANCE WITH THE BARRIER MANUFACTURER'S FIELD WIRING INSTRUCTIONS AND THE APPLICABLE CIRCUIT DIAGRAM.

WARNING - EXPLOSION HAZARD - SUBSTITUTION OF COMPONENTS MAY IMPAIR SUITABILITY FOR CLASS I, DIVISION I.

AVERTISSEMENT - RISQUE D'EXPLOSION - LA SUBSTITUTION DE COMPOSANTS PEUT RENDRE CE MATERIEL INACCEPTABLE POUR LES EMBLEMES DE CLASSE I, DIVISION I.

CAD MAINTAINED (MicroStation)

UNLESS OTHERWISE SPECIFIED DIMENSIONS IN INCHES [mm]. REMOVE ALL BURRS AND SHARP EDGES. MACHINE SURFACE FINISH 125 -TOLERANCE- .X ± .1 [2,5] .XX ± .02 [0,5] .XXX ± .010 [0,25] FRACTIONS ANGLES ± 1/32 ± 2° DO NOT SCALE PRINT	CONTRACT NO.	 ROSEMOUNT® 8200 Market Boulevard • Chanhassen, MN 55317 USA	
	DR. Myles Lee Miller 3/7/01		
	CHK'D	INDEX OF I.S. CSA FOR 3051S	
	APP'D. Paul C. Sundet 8/6/01	SIZE A FSCM NO DWG NO. 03151-1016	
APP'D. GOVT.	SCALE N/A WT. _____ SHEET 1 OF 10		

REVISIONS				
REV	DESCRIPTION	CHG. NO.	APP'D	DATE
AM				

ENTITY CONCEPT APPROVALS

THE ENTITY CONCEPT ALLOWS INTERCONNECTION OF INTRINSICALLY SAFE APPARATUS TO ASSOCIATED APPARATUS NOT SPECIFICALLY EXAMINED IN COMBINATION AS A SYSTEM. THE APPROVED VALUES OF MAX. OPEN CIRCUIT VOLTAGE (V_{oc}) AND MAX. SHORT CIRCUIT CURRENT (I_{sc}) AND MAX. POWER ($V_{oc} \times I_{sc}/4$), FOR THE ASSOCIATED APPARATUS MUST BE LESS THAN OR EQUAL TO THE MAXIMUM SAFE INPUT VOLTAGE (V_{max}), MAXIMUM SAFE INPUT CURRENT (I_{max}), AND MAXIMUM SAFE INPUT POWER (P_{max}) OF THE INTRINSICALLY SAFE APPARATUS. IN ADDITION, THE APPROVED MAX. ALLOWABLE CONNECTED CAPACITANCE (C_a) OF THE ASSOCIATED APPARATUS MUST BE GREATER THAN THE SUM OF THE INTERCONNECTING CABLE CAPACITANCE AND THE UNPROTECTED INTERNAL CAPACITANCE (C_i) OF THE INTRINSICALLY SAFE APPARATUS, AND THE APPROVED MAX. ALLOWABLE CONNECTED INDUCTANCE (L_a) OF THE ASSOCIATED APPARATUS MUST BE GREATER THAN THE SUM OF THE INTERCONNECTING CABLE INDUCTANCE AND THE UNPROTECTED INTERNAL INDUCTANCE (L_i) OF THE INTRINSICALLY SAFE APPARATUS.

FOR OUTPUT CODE A MODEL 3051S
CLASS I, DIV. 1, GROUPS A, B, C AND D

$V_{MAX} = 30V$	V_{OC} IS LESS THAN OR EQUAL TO 30V
$I_{MAX} = 300mA$	I_{SC} IS LESS THAN OR EQUAL TO 300mA
$C_1 = 38nF$	C_A IS GREATER THAN $38nF + C_{cable}$
$L_1 = 0$	L_A IS GREATER THAN $0 H + L_{cable}$

FOR OUTPUT CODE A WITH MODEL 300S JUNCTION BOX, 300S PLANTWEB HOUSING, OR 3051S QUICK CONNECT CLASS I, DIV. 1, GROUPS A, B, C AND D

$V_{MAX} = 30V$	V_{OC} IS LESS THAN OR EQUAL TO 30V
$I_{MAX} = 300mA$	I_{SC} IS LESS THAN OR EQUAL TO 300mA
$C_1 = 11.4nF$	C_A IS GREATER THAN $11.4nF + C_{cable}$
$L_1 = 2.4\mu H$	L_A IS GREATER THAN $2.4\mu H + L_{cable}$

FOR OUTPUT CODE A WITH REMOTE METER CONFIGURATION (OPTION CODES M8 OR M9)
CLASS I, DIV. 1, GROUPS A, B, C AND D

$V_{MAX} = 30V$	V_{OC} IS LESS THAN OR EQUAL TO 30V
$I_{MAX} = 300mA$	I_{SC} IS LESS THAN OR EQUAL TO 300mA
$C_1 = 0nF$	C_A IS GREATER THAN C_{cable}
$L_1 = 58.2\mu H$	L_A IS GREATER THAN $58.2\mu H + L_{cable}$

FOR OUTPUT CODE A WITH HART DIAGNOSTICS SUITE AND MODEL 300S PLANTWEB HOUSING
CLASS I, DIV. 1, GROUPS A, B, C AND D

$V_{MAX} = 30V$	V_{OC} IS LESS THAN OR EQUAL TO 30V
$I_{MAX} = 300mA$	I_{SC} IS LESS THAN OR EQUAL TO 300mA
$C_1 = 11.4nF$	C_A IS GREATER THAN $11.4nF + C_{cable}$
$L_1 = 0$	L_A IS GREATER THAN $0 H + L_{cable}$

NOTE: ENTITY PARAMETERS LISTED APPLY ONLY TO ASSOCIATED APPARATUS WITH LINEAR OUTPUT.

Rosemount Inc. 8200 Market Boulevard Chanhassen, MN 55317 USA	CAD MAINTAINED (MicroStation)		
DR. Myles Lee Miller	SIZE A	FSCM NO	DWG NO. 03151-1016
ISSUED	SCALE N/A	WT. _____	SHEET 2 OF 10

REVISIONS				
REV	DESCRIPTION	CHG. NO.	APP'D	DATE
AM				

FOR OUTPUT CODE B (SAFETY CERTIFIED SIS) WITH MODEL 300S PLANTWEB HOUSING
 CLASS I, DIV. 1, GROUPS A, B, C AND D

$V_{MAX} = 30V$	V_{OC} IS LESS THAN OR EQUAL TO 30V
$I_{MAX} = 300mA$	I_{SC} IS LESS THAN OR EQUAL TO 300mA
$C_1 = 11.4nF$	C_A IS GREATER THAN 11.4nF + C_{cable}
$L_1 = 570\mu H$	L_A IS GREATER THAN 570 μH + L_{cable}

FOR OUTPUT CODE F or W WITH MODEL 300S PLANTWEB HOUSING
 CLASS I, DIV. 1, GROUPS A, B, C AND D

$V_{MAX} = 30V$	V_{OC} IS LESS THAN OR EQUAL TO 30V
$I_{MAX} = 300mA$	I_{SC} IS LESS THAN OR EQUAL TO 300mA
$C_1 = 0\mu f$	C_A IS GREATER THAN 0 μf + C_{cable}
$L_1 = 0\mu H$	L_A IS GREATER THAN 0 μH + L_{cable}

NOTE: ENTITY PARAMETERS LISTED APPLY ONLY TO ASSOCIATED APPARATUS WITH LINEAR OUTPUT.

Rosemount Inc. 8200 Market Boulevard Chanhassen, MN 55317 USA		CAD MAINTAINED (MicroStation)		
DR. Myles Lee Miller	SIZE A	FSCM NO	DWG NO.	03151-1016
ISSUED	SCALE N/A	WT.	SHEET	3 OF 10

Rosemount 3051S Series

REVISIONS				
REV	DESCRIPTION	CHG. NO.	APP'D	DATE
AM				

CSA INTRINSIC SAFETY APPROVALS
 CIRCUIT CONNECTION WITH BARRIER OR CONVERTER

Ex ia
 INTRINSICALLY SAFE/SECURITE INTRINSEQUE
 4-20 mA, ("A" or "B" OUTPUT CODE)

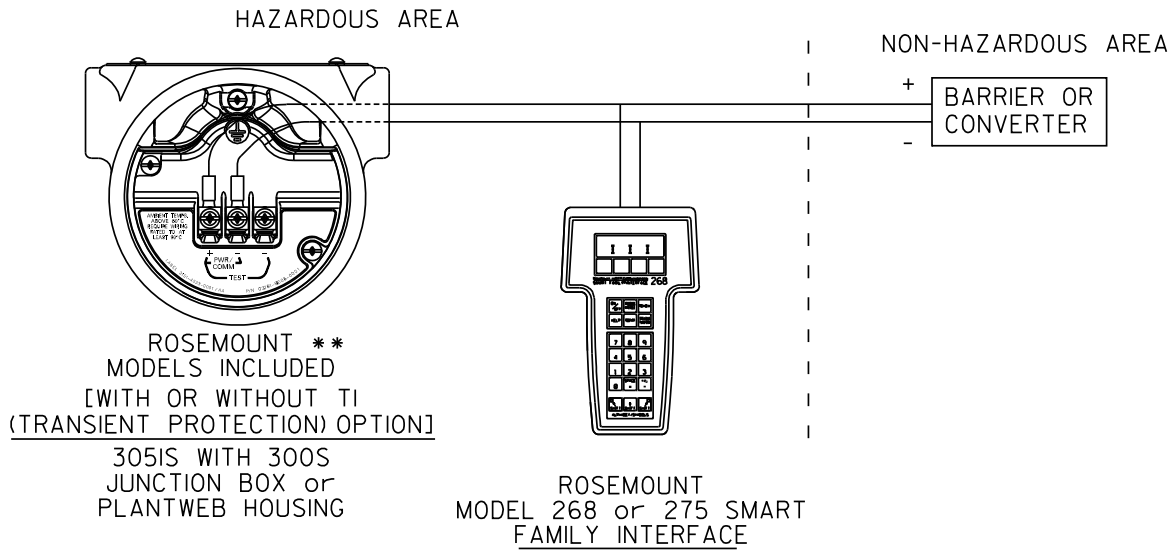

** FOR FIELDBUS OPTIONS("F" or "W" OUTPUT CODE),
 SEE PAGE 6 FOR PARAMETERS AND CIRCUIT CONNECTION TO BARRIER.

Rosemount Inc. 8200 Market Boulevard Chanhassen, MN 55317 USA		CAD MAINTAINED (MicroStation)		
DR. Myles Lee Miller 3/7/001	SIZE A	FSCM NO	DWG NO.	03151-1016
ISSUED	SCALE N/A	WT.	SHEET	4 OF 10

REVISIONS				
REV	DESCRIPTION	CHG. NO.	APP'D	DATE
AM				

CSA INTRINSIC SAFETY APPROVALS
 CIRCUIT CONNECTION WITH BARRIER OR CONVERTER
 Ex ia
 INTRINSICALLY SAFE/SECURITE INTRINSEQUE
 4-20 mA, ("A" OUTPUT CODE)

HAZARDOUS AREA

NON-HAZARDOUS AREA

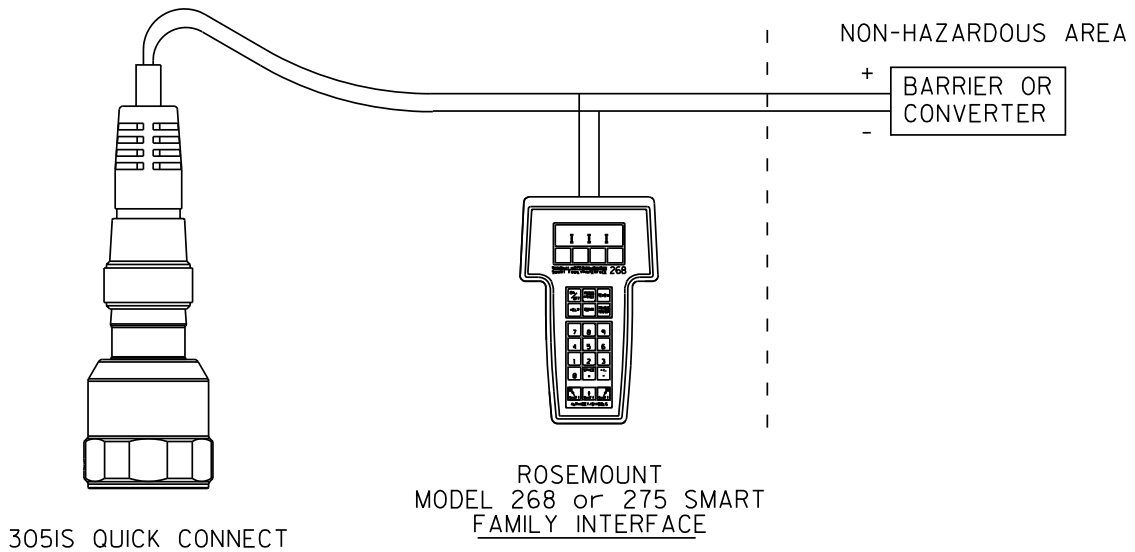

Rosemount Inc.
 8200 Market Boulevard
 Chanhassen, MN 55317 USA

DR. **Myles Lee Miller** 8/17/05

ISSUED

SIZE A		FSCM NO	DWG NO.	CAD MAINTAINED (MicroStation)	
SCALE N/A		WT.	03151-1016	SHEET 5 OF 10	

REVISIONS				
REV	DESCRIPTION	CHG. NO.	APP'D	DATE
AM				

CSA INTRINSIC SAFETY APPROVALS
CIRCUIT CONNECTION WITH BARRIER OR CONVERTER

Ex ia
INTRINSICALLY SAFE/SECURITE INTRINSEQUE
4-20 mA, ("A" OUTPUT CODE)

MAXIMUM CABLE PARAMETERS
CAPACITANCE - 50 pf / Ft
INDUCTANCE - 0.251μH / Ft
LENGTH - 100 Ft
RECOMMENDED CABLE -
BELDEN 3084A DEVICE NET
OR BELDEN 123084A
ARMORED DEVICE NET

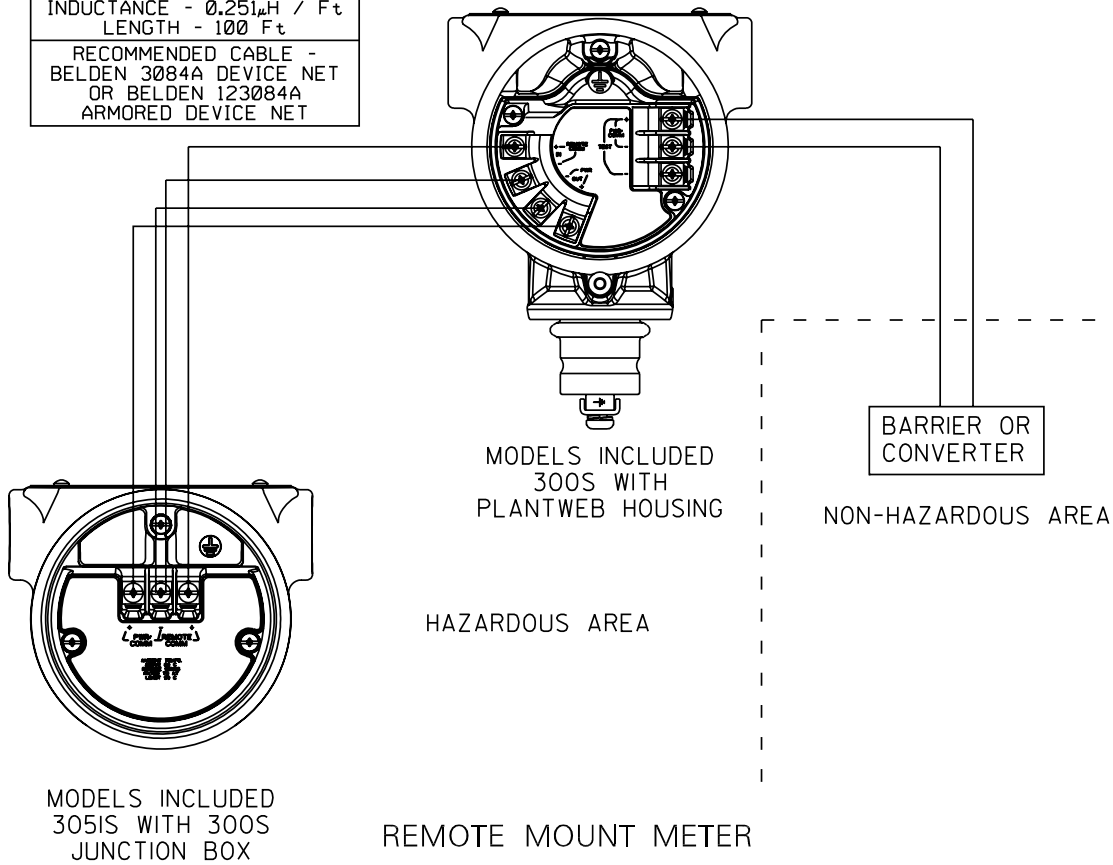

Rosemount Inc. 8200 Market Boulevard Chanhassen, MN 55317 USA		CAD MAINTAINED (MicroStation)		
DR. Myles Lee Miller	SIZE A	FSCM NO	DWG NO.	03151-1016
ISSUED	SCALE N/A	WT.	SHEET	6 OF 10

		REVISIONS			
REV	DESCRIPTION	CHG. NO.	APP'D	DATE	
AM					
4-20 mA, ("A" or "B" OUTPUT CODE)					
DEVICE	PARAMETERS	APPROVED FOR CLASS I, DIV.I			
CSA APPROVED SAFETY BARRIER	30 V OR LESS * 330 OHMS OR MORE * 28 V OR LESS * 300 OHMS OR MORE 25 V OR LESS 200 OHMS OR MORE * 22 V OR LESS * 180 OHMS OR MORE	GROUPS A, B, C, D			
FOXBORO CONVERTER 2AI-I2V-CGB, 2AI-I3V-CGB, 2AS-I3I-CGB, 3A2-I2D-CGB, 3A2-I3D-CGB, 3AD-I3I-CGB, 3A4-I2D-CGB, 2AS-I2I-CGB, 3F4-I2DA		GROUPS B, C, D			
CSA APPROVED SAFETY BARRIER	30 V OR LESS 150 OHMS OR MORE	GROUPS C, D			
Rosemount Inc. 8200 Market Boulevard Chanhassen, MN 55317 USA					
		CAD MAINTAINED (MicroStation)			
DR.	Myles Lee Miller	SIZE A	FSCM NO	DWG NO. 03151-1016	
ISSUED		SCALE N/A	WT. _____	SHEET 7 OF 10	

Rosemount 3051S Series

REVISIONS				
REV	DESCRIPTION	CHG. NO.	APP'D	DATE
AM				

FIELDBUS, ("F" or "W" OUTPUT CODE)

DEVICE	PARAMETERS	APPROVED FOR CLASS I, DIV. I
CSA APPROVED SAFETY BARRIER	30 V OR LESS 300 OHMS OR MORE 28 V OR LESS 235 OHMS OR MORE 25 V OR LESS 160 OHMS OR MORE 22 V OR LESS 100 OHMS OR MORE	GROUPS A, B, C, D

CSA INTRINSIC SAFETY APPROVALS
CIRCUIT CONNECTION WITH BARRIER OR CONVERTER

Ex ia
INTRINSICALLY SAFE/SECURITE INTRINSEQUE
FIELDBUS, ("F" or "W" OUTPUT CODE)

HAZARDOUS AREA

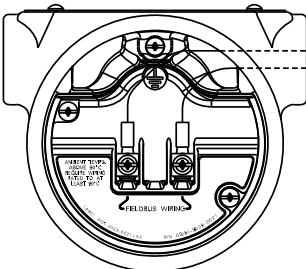

NON-HAZARDOUS AREA

+
BARRIER OR CONVERTER
-

ROSEMOUNT **
MODELS INCLUDED
[WITH OR WITHOUT TI
(TRANSIENT PROTECTION) OPTION]
3051S WITH 300S
PLANTWEB HOUSING

WARNING - EXPLOSION HAZARD - SUBSTITUTION OF COMPONENTS
MAY IMPAIR SUITABILITY FOR CLASS I, DIVISION I.

AVERTISSEMENT - RISQUE D'EXPLOSION - LA SUBSTITUTION DE COMPOSANTS
PEUT RENDRE CE MATERIEL INACCEPTABLE POUR LES EMBLACEMENTS
DE CLASSE I, DIVISION I.

Rosemount Inc. 8200 Market Boulevard Chanhassen, MN 55317 USA		CAD MAINTAINED (MicroStation)		
DR. Myles Lee Miller	SIZE A	FSCM NO	DWG NO.	Ø3151-1Ø16
ISSUED	SCALE N/A	WT. _____	SHEET 8 OF 10	

REVISIONS				
REV	DESCRIPTION	CHG. NO.	APP'D	DATE
AM				

FISCO CONCEPT

THE FISCO CONCEPT ALLOWS INTERCONNECTION OF INTRINSICALLY SAFE APPARATUS TO ASSOCIATED APPARATUS NOT SPECIALLY EXAMINED IN SUCH COMBINATION. THE CRITERIA FOR INTERCONNECTION IS THAT THE VOLTAGE (V_{max}), THE CURRENT (I_{max}), AND THE POWER (P_{max}) WHICH AN INTRINSICALLY SAFE APPARATUS CAN RECEIVE AND REMAIN INTRINSICALLY SAFE CONSIDERING FAULTS, MUST BE EQUAL OR GREATER THAN VOLTAGE (V_{oc}), AND CURRENT (I_{sc}) WHICH CAN BE DELIVERED BY THE ASSOCIATED APPARATUS, CONSIDERING FAULTS AND APPLICABLE FACTORS. IN ADDITION, THE MAXIMUM UNPROTECTED CAPACITANCE (C_1) AND THE INDUCTANCE (L_1) OF EACH APPARATUS (OTHER THAN THE TERMINATION) CONNECTED TO THE FIELD BUS MUST BE LESS THAN OR EQUAL TO 5 nF AND 10 μ H RESPECTIVELY.

IN EACH SEGMENT ONLY ONE ACTIVE DEVICE, NORMALLY THE ASSOCIATED APPARATUS, IS ALLOWED TO PROVIDE THE NECESSARY ENERGY FOR THE FIELD BUS SYSTEM. THE VOLTAGE (V_{oc}) OF THE ASSOCIATED APPARATUS IS LIMITED TO A RANGE OF 14V TO 24Vd.c. ALL OTHER EQUIPMENT CONNECTED TO THE BUS CABLE HAS TO BE PASSIVE, MEANING THAT THEY ARE NOT ALLOWED TO PROVIDE ENERGY TO THE SYSTEM, EXCEPT A LEAKAGE CURRENT OF 50 μ A FOR EACH CONNECTED DEVICE. SEPARATELY POWERED EQUIPMENT NEEDS GALVANIC ISOLATION TO ASSURE THAT THE INTRINSICALLY SAFE FIELD BUS CIRCUIT REMAINS PASSIVE.

THE CABLE USED TO INTERCONNECT DEVICES NEEDS TO HAVE THE PARAMETERS IN THE FOLLOWING RANGE:

- Loop Resistance R': 15.....150 Ohm/km
- Inductance per unit length L': 0.4.....1 mH/km
- Capacitance per unit length C': 80.....200 nF
- C' = C' line/line + 0.5C' line/screen, if both lines are floating, or
- C' = C' line/line + C' line/screen, if the screen is connected to one line
- Length of trunk cable: less than or equal to 1000m
- Length of spur cable: less than or equal to 30m
- Length of spur splice: less than or equal to 1m

AT EACH END OF THE TRUNK CABLE AN APPROVED INFALLIBLE LINE TERMINATION WITH THE FOLLOWING PARAMETERS IS SUITABLE:

R = 90.....1000hm C = 0.....2.2uF

ONE OF THE ALLOWED TERMINATIONS MIGHT ALREADY BE INTEGRATED IN THE ASSOCIATED APPARATUS. THE NUMBER OF PASSIVE APPARATUS CONNECTED TO THE BUS SEGMENT IS NOT LIMITED DUE TO I. S. REASONS. IF THE ABOVE RULES ARE RESPECTED, UP TO A TOTAL LENGTH OF 1000 m (SUM OF TRUNK AND ALL SPUR CABLES) OF CABLE IS PERMITTED. THE INDUCTANCE AND THE CAPACITANCE OF THE CABLE WILL NOT IMPAIR THE INTRINSIC SAFETY OF THE INSTALLATION.

Rosemount Inc. 8200 Market Boulevard Chanhassen, MN 55317 USA		CAD MAINTAINED (MicroStation)		
DR. Myles Lee Miller	SIZE A	FSCM NO	DWG NO.	03151-1016
ISSUED	SCALE	N/A	WT.	SHEET 9 OF 10

Rosemount 3051S Series

REVISIONS				
REV	DESCRIPTION	CHG. NO.	APP'D	DATE
AM				

NOTES:

1. APPROVED ASSOCIATED APPARATUS MUST BE INSTALLED IN ACCORDANCE WITH MANUFACTURER'S INSTRUCTIONS.
2. CSA APPROVED ASSOCIATED APPARATUS MUST MEET THE FOLLOWING PARAMETERS:
Voc LESS THAN OR EQUAL TO (Vmax AND Isc LESS THAN OR EQUAL TO (Imax).
3. THE MAXIMUM NON-HAZARDOUS AREA VOLTAGE MUST NOT EXCEED 250V.
4. THE INSTALLATION MUST BE IN ACCORDANCE WITH CANADIAN ELECTRICAL
5. CAUTION: USE ONLY SUPPLY WIRES SUITABLE FOR 5°C ABOVE SURROUNDING TEMPERATURE.
6. WARNING: SUBSTITUTION OF COMPONENTS MAY IMPAIR INTRINSIC SAFETY.
7. THIS PRODUCT MEETS THE DUAL SEAL REQUIREMENTS OF ANSI/ISA 12.27.01. NO ADDITIONAL PROCESS SEALING IS REQUIRED. THE DUAL SEAL PROCESS TEMPERATURE RANGE IS -50°C TO 315°C. FOR THE IN-SERVICE LIMITS APPLICABLE TO A SPECIFIC MODEL, SEE "PROCESS TEMPERATURE LIMITS" IN APPENDIX "A" OF THE PRODUCT MANUAL.

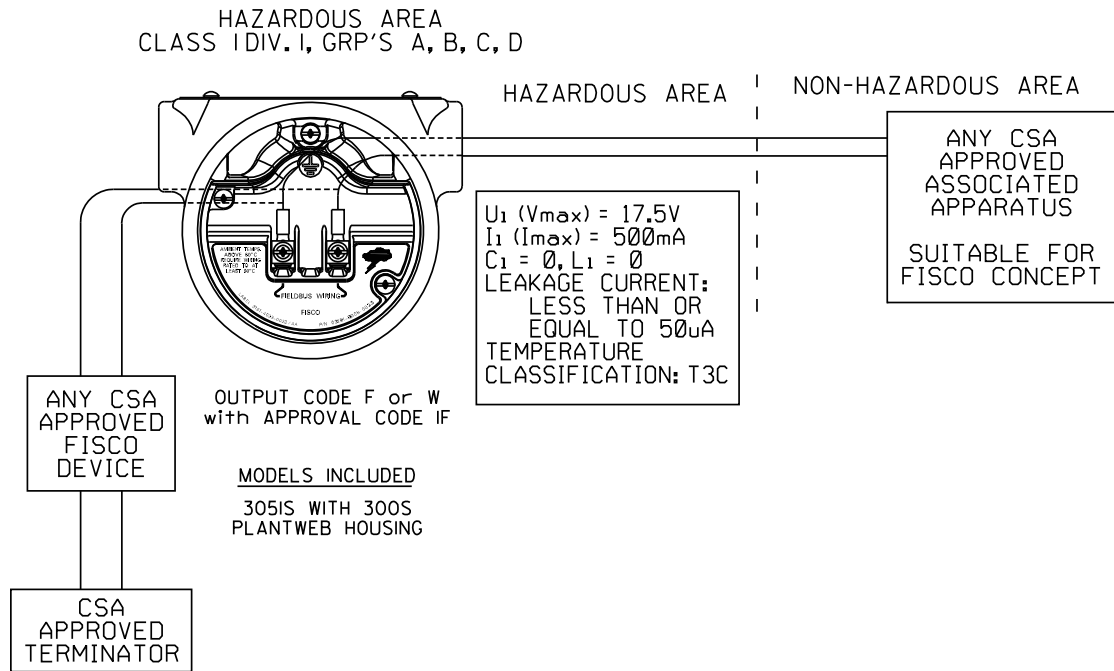

Rosemount Inc. 8200 Market Boulevard Chanhassen, MN 55317 USA		CAD MAINTAINED (MicroStation)		
DR. Myles Lee Miller	SIZE A	FSCM NO	DWG NO. Ø3151-1Ø16	
ISSUED	SCALE N/A	WT. _____	SHEET 1Ø OF 1Ø	

KEMA

CONFIDENTIAL AND PROPRIETARY INFORMATION IS CONTAINED HEREIN AND MUST BE HANDLED ACCORDINGLY.	REVISIONS					
	ZONE	REV	DESCRIPTION	CHG. NO.	APP'D	DATE
		AB	ADD 3051SL AND TRADITIONAL HOUSING	RTC1015145	B.L.H.	4/7/03
		AC	UPDATE NOTE 8	RTC1025701	T.T.S.	3/5/08
		AD	UPDATE NOTE 8 AND THREAD DESCRIPTION	RTC1026395	T.T.S.	6/30/08

NOTES:

1. WIRING METHOD SUITABLE FOR CATEGORY 2, (ZONE 1) WITH ANY LENGTH.
2. TRANSMITTER MUST NOT BE CONNECTED TO EQUIPMENT GENERATING MORE THAN 250 VAC.
3. ALL CONDUIT THREADS TO BE ASSEMBLED WITH FIVE FULL THREADS MINIMUM.
4. COMPONENTS REQUIRED TO BE APPROVED MUST BE APPROVED FOR GAS GROUP APPROPRIATE TO AREA CLASSIFICATION.
5. 3051SC, 3051ST OR 3051SL SENSOR MODULE MUST BE INSTALLED WITH CENELEC FLAMEPROOF APPROVED 300S1, 300S2 OR 300S4 HOUSING ATTACHED TO MEET FLAMEPROOF INSTALLATION REQUIREMENTS.
6. INSTALLATION TO BE IN ACCORDANCE WITH APPLICABLE LOCAL REQUIREMENTS.
7. 300S1, 300S2 OR 300S4 HOUSING MUST BE INSTALLED WITH CENELEC FLAMEPROOF APPROVED 3051SC, 3051ST OR 3051SL SENSOR MODULE ATTACHED TO MEET FLAMEPROOF INSTALLATION REQUIREMENTS.
8. UNUSED CONDUIT ENTRY MUST BE CLOSED WITH A EN/IEC 60079-1 FLAMEPROOF APPROVED BLANKING ELEMENT.

CAD Maintained. (Pro/E)

UNLESS OTHERWISE SPECIFIED DIMENSIONS IN INCHES (mm). REMOVE ALL BURRS AND SHARP EDGES. MACHINE SURFACE FINISH 125 -TOLERANCES- .X ± .1 [2,5] .XX ± .02 [0,5] .XXX ± .010 [0,25] FRACTIONS ANGLES ± 1/32 ± 2° DO NOT SCALE PRINT	CONTRACT NO.		 ROSEMOUNT® 8200 Market Boulevard • Chanhassen, MN 55317 USA				
	DR. <i>Myles Lee Miller</i>	8/28/00				TITLE	
	CHK'D		APP'D <i>Paul C. Sundet</i>	9/11/00	SIZE A	FSCM NO.	DRAWING NO. 03151-1023
	APP'D GOVT.		SCALE	1 : 4	WT.	SHEET	OF 3

Form Rev. AC

REVISIONS					
ZONE	REV	DESCRIPTION	CHG. NO.	APP'D	DATE
	AD				

COMPONENT IDENTIFICATION

300S1____, PLANTWEB
300S4____, TRADITIONAL
(DUAL COMPARTMENT HOUSING)

300S2____
JUNCTION BOX HOUSING
(SINGLE COMPARTMENT)

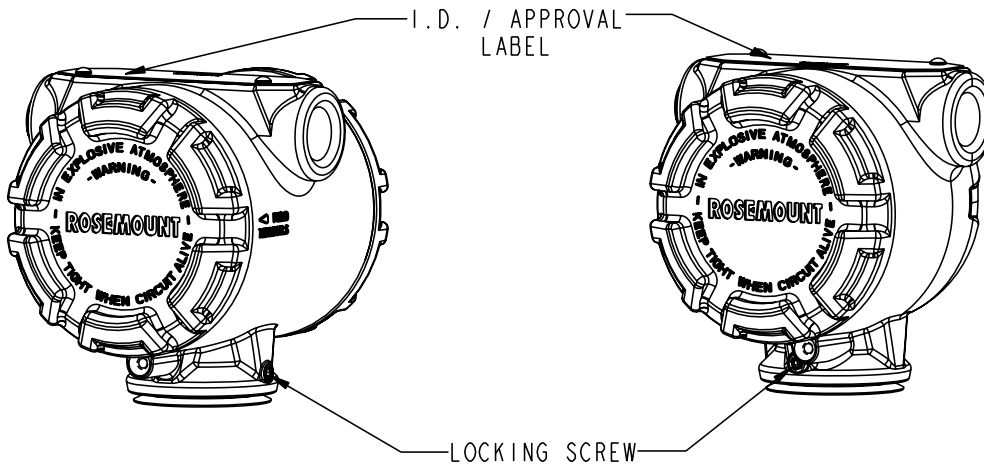

3051S_C____
3051S_L____
SCALABLE COPLANAR
PRESSURE TRANSMITTER

3051S_T____
SCALABLE IN-LINE
PRESSURE TRANSMITTER

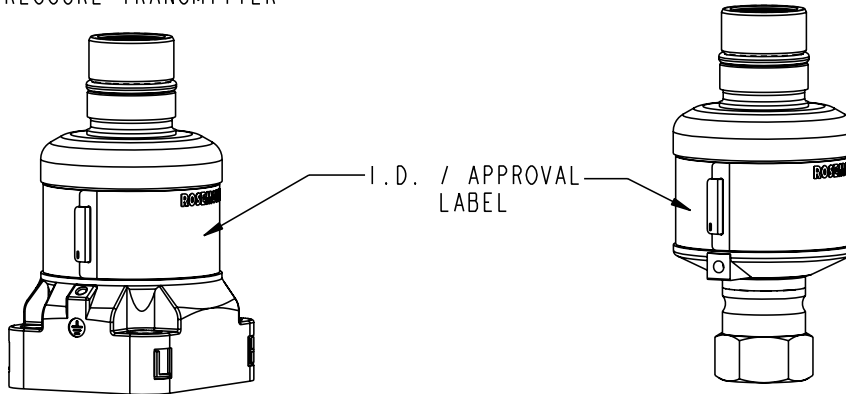

Rosemount Inc. 8200 Market Boulevard Chanhassen, MN 55317 USA			CAD Maintained, (Pro/E)		
DR.	Myles Lee Miller	8/28/00	SIZE A	FSCM NO.	DWG NO. 03151-1023
ISSUED			SCALE 1:2	WT.	SHEET 2 OF 3

Form Rev AC

REVISIONS					
ZONE	REV	DESCRIPTION	CHG. NO.	APP'D	DATE
	AD				

HOUSING TO MODULE ASSEMBLY

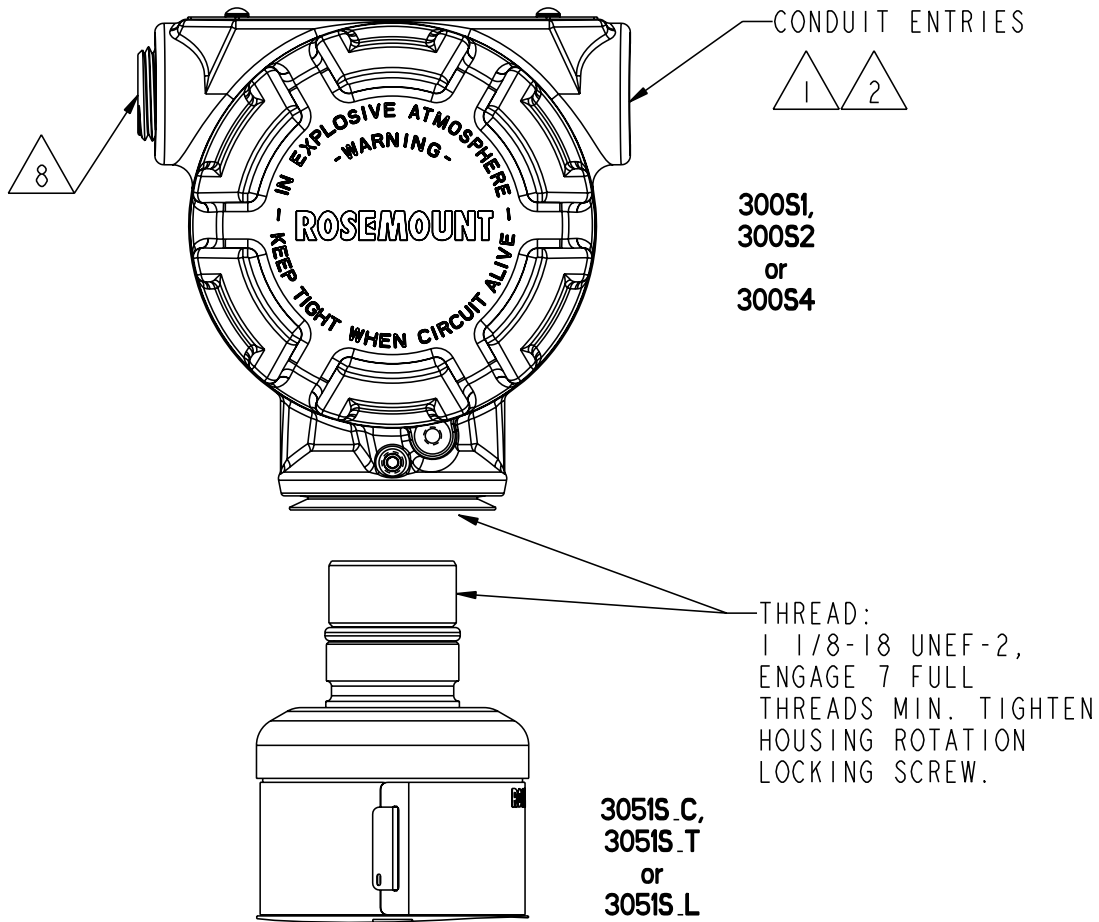

Rosemount Inc.
 8200 Market Boulevard
 Chanhassen, MN 55317 USA

CAD Maintained, (Pro/E)

DR. <i>Myles Lee Miller</i>	8/28/00	SIZE A	FSCM NO.	DWG NO. 03151-1023
ISSUED		SCALE 1 : 4	WT.	SHEET 3 OF 3

Form Rev. AC

Rosemount 3051S Series

Reference Manual
00809-0100-4801, Rev FA
October 2010

Index

A

- Address
 - Changing 3-31
- Alarm 3-19
 - Burst mode values 3-19
 - Failure mode values 3-18
 - Level configuration 3-19
 - Level verification 3-20
 - Multidrop mode values 3-20
- Alarm direction configuration 2-15
- Alerts 3-20
- Analog output trim 4-7
- Approvals
 - Drawings B-10

B

- Basic setup 3-13
- Bolts
 - Installation 2-6
 - Material 2-7
- Brackets
 - Mounting 2-6
- Burst mode
 - Advanced functions 3-29
 - Alarm and saturation values 3-19

C

- Calibration 4-1
 - Choosing a procedure 4-5
 - Frequency, determining 4-4
 - Full trim 4-6
 - Overview 4-2
 - Recal factory trim
 - Analog output 4-10
 - Sensor trim 4-7
 - Sensor trim 4-5
 - Tasks 4-2
 - Zero trim 4-6
- Cloning 3-27
- Commissioning
 - HART protocol
 - AMS 3-2
 - Field Communicator 3-2
- Compensating line pressure 4-10

Configuration

- Alarm and saturation 3-19
 - Applying a user configuration 3-29
 - Cloning 3-27
 - Data review 3-4
 - LCD meter 3-17
 - Recalling 3-27
 - Reusable copy 3-28
 - Saving 3-27
 - Scaled variable 3-21
- ## Configure
- Alarm direction 2-15
- ## Considerations
- Compatibility 2-2
 - Electrical, fieldbus 2-18
 - Environmental 2-3
 - General 2-2
 - Mechanical 2-2

D

- Damping 3-16
- Detailed setup 3-18
- Diagnostics and service 3-25
 - Loop
 - Test 3-26
 - Messages 4-13
- Diagrams
 - Bench hook-up 3-3
 - Field hook-up 3-3
 - HART terminal block 2-16
 - Installation 2-11
 - Multidrop network 3-30
 - Typical multidrop network 3-30

Digital to analog trim

- Other scale 4-9

Disassembly

- Before disassembling 5-3
 - Remove assembly 5-4
 - Remove from service 5-3
 - Remove housing 5-4
 - Removing electronics board 5-4
 - Removing sensor module 5-4
 - Removing terminal block 5-4
- ## Disassembly procedures 5-3

Drawings

- Approval B-10

E

- Electronics board
 - Removing 5-4
- Environmental considerations 2-3

F

- Failure mode alarm and saturation
 - Values 3-18
- Full trim 4-6

G

- Gas mounting requirements 2-10
- Grounding 2-19
 - External assembly 2-21
 - Internal connection 2-21
 - Signal wiring grounding 2-17

H

- Housing Rotation
 - Junction Box 2-6, 2-12
 - PlantWeb 2-6, 2-12

I

- Impulse piping 2-9
- Installation 2-5
 - 304 manifold 2-24
 - 305 manifold 2-23
 - 306 manifold 2-23
 - Alarm direction 2-15
 - Bolts 2-6
 - Cover 2-5
 - HART flowchart 2-4
 - Housing rotation 2-12
 - LCD meter 2-21
 - Mounting 2-6
 - Brackets 2-6
 - Torque values 2-7
 - Power supply
 - HART protocol 2-17
 - Power up 2-16
 - Process Flange Orientation 2-5
 - Signal wiring grounding 2-17
 - Wiring 2-16
- Introduction 1-1

L

- LCD meter 3-17
 - Configuration 3-17
 - Installing 2-21
 - Options 3-17
- Lightning 2-16
- Line pressure
 - Compensating 4-10
- Liquid mounting requirements 2-10
- Loop
 - Setting to manual 3-2
- Loop test 3-26
- Low flow cutoff 3-21

Rosemount 3051S Series

M

Maintenance	4-1
Manifold installations	2-23
Manifolds	2-24
Manual	
Use of	1-1
Mechanical considerations	2-2
Mounting	
Bolt installation	
Torque values	2-7
Installation	2-6
Mounting requirements	2-10
Gas	2-10
Liquid	2-10
Steam	2-10
Multidrop communication	3-20
Advanced functions	3-30
Communicating	3-31
Diagram	3-30

N

NAMUR-compliant values	3-18
------------------------	------

O

Operation	4-1
Options	
LCD meter	3-17
Output	
Process variables	3-12
Recal factory trim	4-10
Sensor temperature	3-12
Transfer function	3-13

P

Piping, impulse	2-9
Power supply	
HART protocol	2-17
Power up	2-16
Power supply HART protocol	2-17
Remote meter	2-18
Process alerts	3-20
Process connections	2-11
Process variables	3-12
Units	3-13

R

Reassembly	5-5
Attaching SuperModule	5-5
Install terminal block	5-5
Process sensor body	5-5
Reassembly procedures	5-5
Recall factory trim	
Analog output	4-10
Sensor trim	4-7
Recalling	3-27

Re-mapping	3-24
Remote Meter Wiring	2-18
Remote meter wiring	
Wiring diagram	2-19
Rerange	3-14
AMS only	3-16
Field Communicator only	3-15
Pressure Input Source	
With AMS	3-16
Pressure input source	
With Field Communicator	3-15
With local zero and span	3-16
Returning products and materials	5-7
Reusable copy	3-28

S

Saturation	
Burst mode values	3-19
Failure mode values	3-18
Level configuration	3-19
Multidrop mode values	3-20
Saving a configuration	3-27
Scaled variable configuration	3-21
Security (Write Protect)	2-13
Sensor module	
Removing	5-4
Sensor temperature	3-12
Unit	3-25
Sensor trim	4-5
Service and Diagnostics	3-25
Service Support	1-3
Setup	
Basic	3-13
Detailed	3-18
Signal wiring grounding	2-17
Spare parts	A-42
Steam mounting requirements	2-10
SuperModule	
Installing	5-5
Surges	2-18
Switches and jumpers	
Configuration	
Junction Box	2-14
PlantWeb	2-14
Security (Write Protect)	2-13

T

Tagging	2-2
Terminal block	
Installing	5-5
Removing	5-4
Terminal block diagrams	
HARTprotocol	2-16
Terminal Side	2-5
Torque values	2-7

Transfer function	3-13
Transient	
Protection	2-16
Transients	2-16
Transmitter functions	4-1
Trim	
Analog output	4-7
Digital to Analog	4-8
Other scale	4-9
Full	4-6
Recall factory	
Analog output	4-10
Sensor trim	4-7
Sensor	4-5
Zero	4-6
Troubleshooting	5-1
Reference table	5-2

U

Units,Process variable	3-13
Upgrades	4-15
Feature boards	4-15

W

Wiring	
Remote meter	2-18
Signal wiring grounding	2-17
Surges	2-18
Transients	2-16
Wiring diagrams	
Bench hook-up	3-3
Field hook-up	3-3

Z

Zero trim	4-6
-----------	-----

Reference Manual

00809-0100-4801, Rev FA

October 2010

Rosemount 3051S Series

Standard Terms and Conditions of Sale can be found at www.rosemount.com/terms_of_sale

The Emerson logo is a trademark and service mark of Emerson Electric Co.

Rosemount and the Rosemount logotype are registered trademarks of Rosemount Inc.

SuperModule and Coplanar trademarks of Rosemount Inc.

PlantWeb is a mark of one of the Emerson Process Management companies.

HART is a registered trademark of the HART Communications Foundation.

ASP Diagnostics Suite is a trademark of one of the Emerson Process Management companies.

Syltherm and D.C. are registered trademarks of Dow Corning Co.

Neobee M-20 is a registered trademark of Stephan Chemical Co.

The 3-A symbol is a registered trademark of the 3-A Sanitary Standards Symbol Council.

FOUNDATION fieldbus is a registered trademark of the Fieldbus Foundation.

Grafoil is a trademark of Union Carbide Corp.

All other marks are the property of their respective owners.

© 2010 Rosemount, Inc. All rights reserved.

Emerson Process Management Rosemount Measurement

8200 Market Boulevard
Chanhassen MN 55317 USA
Tel (USA) 1 800 999 9307
Tel (International) +1 952 906 8888
Fax +1 952 949 7001

Emerson Process Management GmbH & Co.

Argelsrieder Feld 3
82234 Wessling
Germany
Tel 49 (8153) 9390
Fax 49 (8153) 939172

Emerson Process Management Asia Pacific Private Limited

1 Pandan Crescent
Singapore 128461
T (65) 6777 8211
F (65) 6777 0947
Enquiries@AP.EmersonProcess.com

Beijing Rosemount Far East Instrument Co., Limited

No. 6 North Street,
Hepingli, Dong Cheng District
Beijing 100013, China
T (86) (10) 6428 2233
F (86) (10) 6422 8586